

Parts List			
ITEM	QTY	PART NUMBER	DESCRIPTION
1	1	075DXM	3/4" COUPLER X 3/4" NPT
2	1	75G	COUPLING GASKET
3	2	75K	1" CAM ARM W/ RING
4	2	75P	CAM ARM PIN
5	1	100DECAL	Mini Coupling Decal

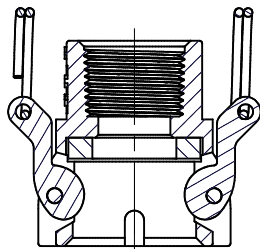

SECTION A-A
SCALE 1 : 1

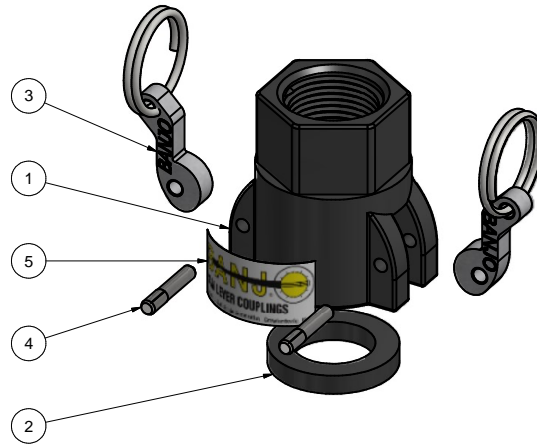
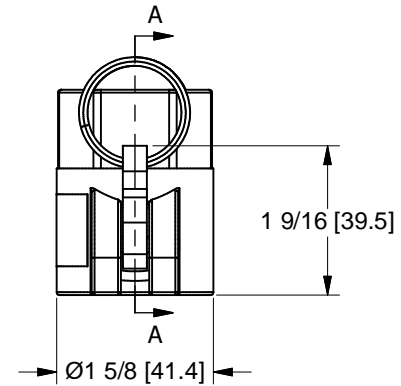
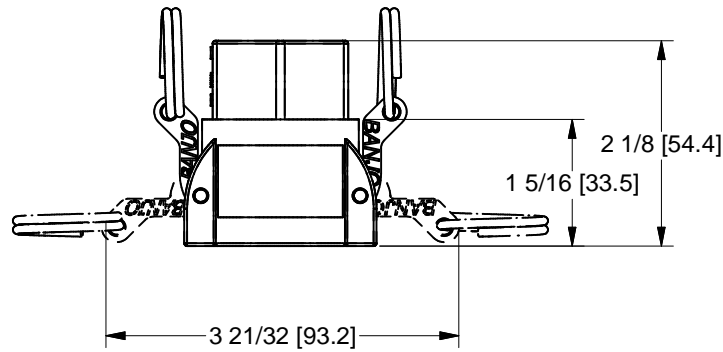

BANJO CORPORATION

150 BANJO DRIVE, CRAWFORDSVILLE, IN 47933
 WEB SITE: WWW.BANJOCORP.COM
 E-MAIL: SALES1@BANJOCORP.COM

DESCRIPTION

3/4" Coupler x 3/4" Female Thd

PART NUMBER

075D

THIS DRAWING AND ALL INFORMATION CONTAINED THEREON ARE THE EXCLUSIVE PROPERTY OF BANJO CORPORATION.

UNLESS SPECIFICALLY NOTED, THIS DRAWING AND ITEMS SHOWN ON THIS DRAWING ARE SUBJECT TO CHANGE AT ANY TIME.

Note: Parts are to be bagged.