

Parts List			
ITEM	QTY	PART NUMBER	DESCRIPTION
1	1	100DBXM	1" Female Coupler X 1" BSPT Female Thd, Machined
2	1	100G	1" COUPLING GASKET, EPDM
3	2	100K	1" CAM ARM W/ RING
4	2	100P	PIN

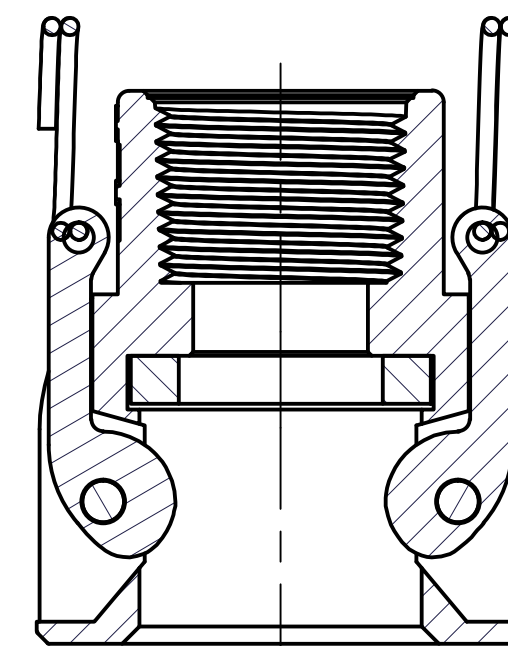

SECTION A-A
SCALE 1 : 1

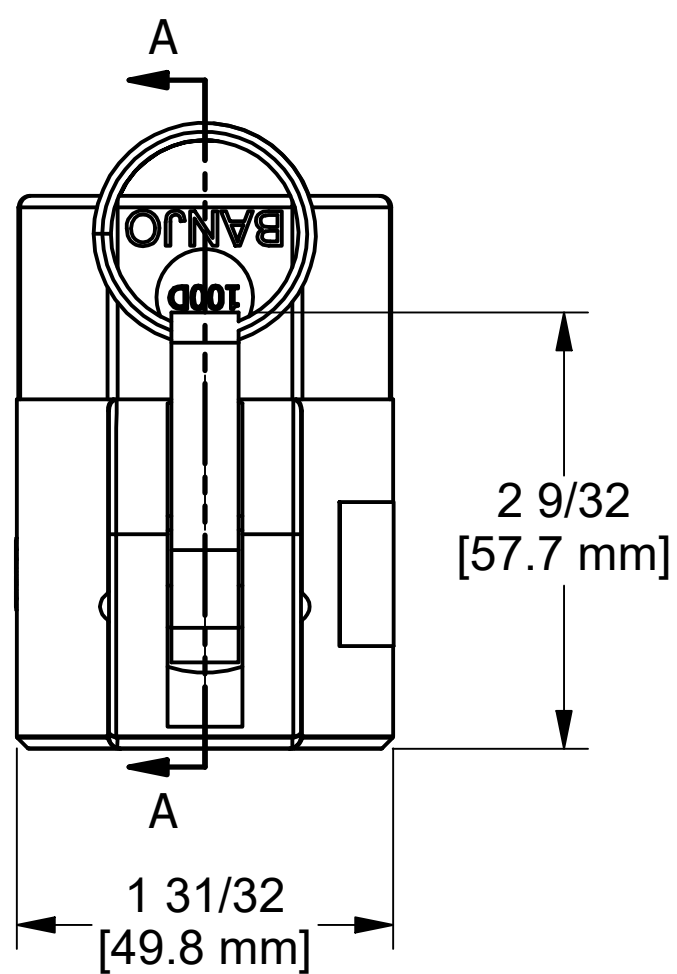
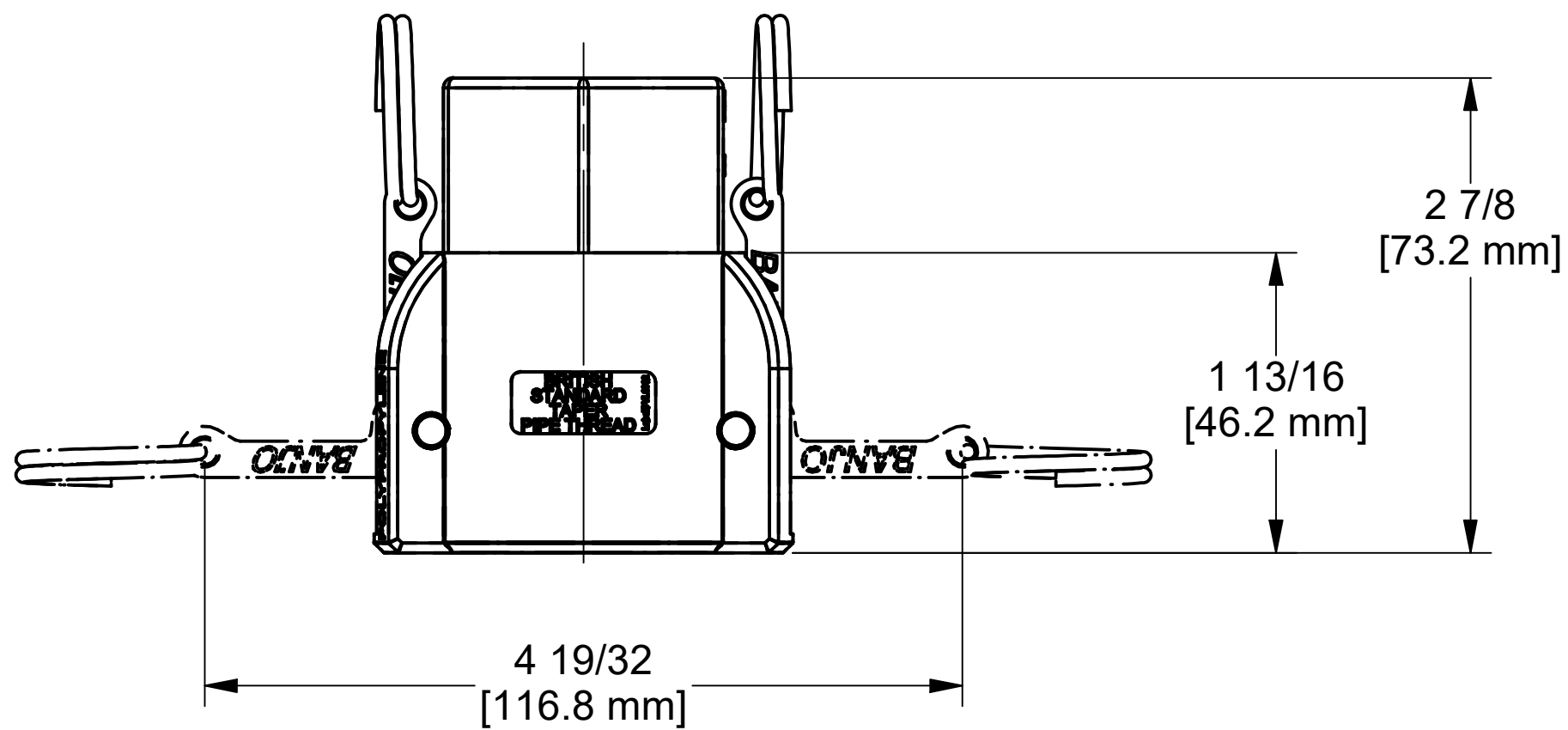
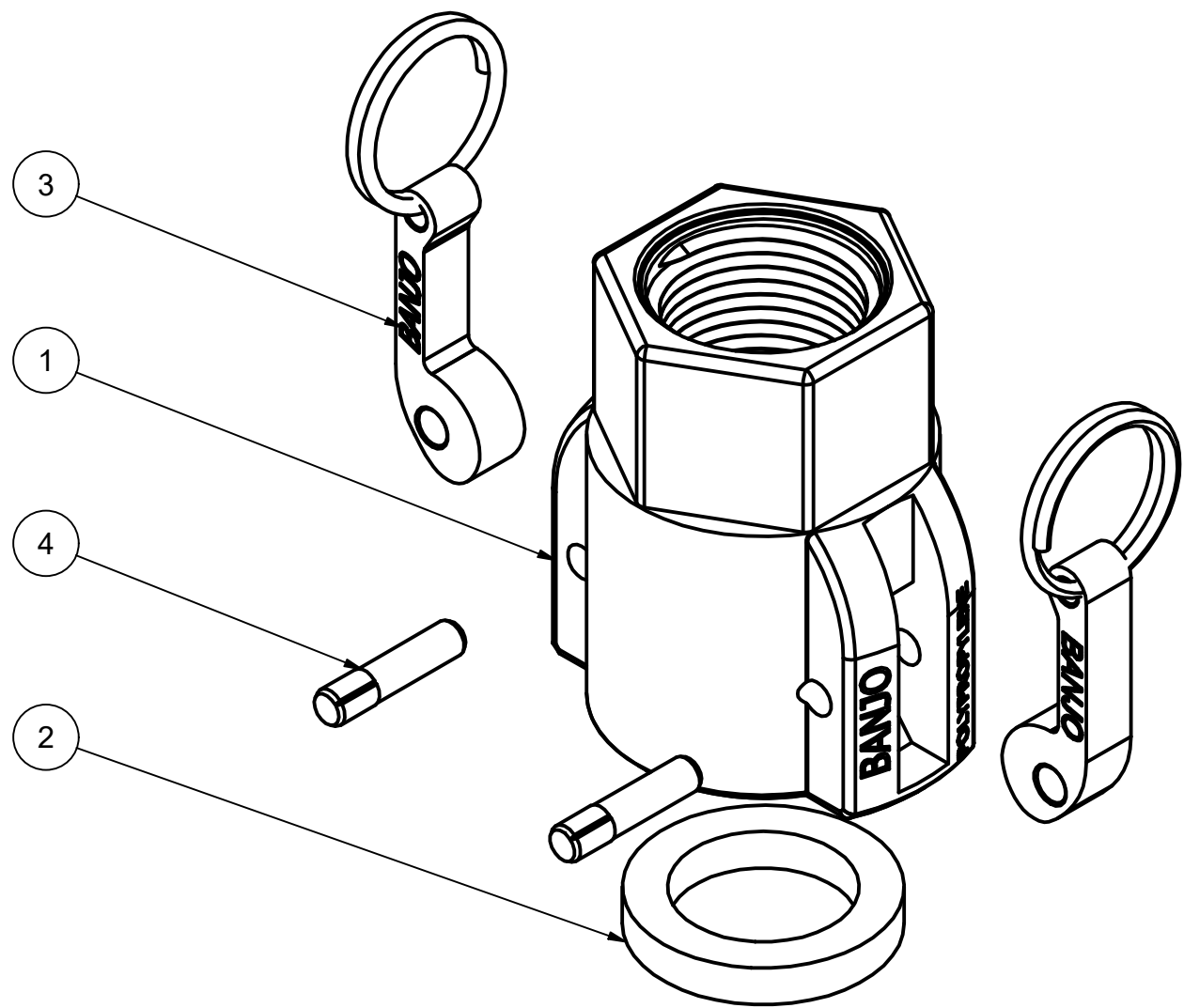

THIS DRAWING AND ALL INFORMATION CONTAINED THEREON ARE THE EXCLUSIVE PROPERTY OF BANJO CORPORATION.

UNLESS SPECIFICALLY NOTED, THIS DRAWING AND ITEMS SHOWN ON THIS DRAWING ARE SUBJECT TO CHANGE AT ANY TIME.

BANJO CORPORATION
150 BANJO DRIVE, CRAWFORDSVILLE, IN 47933
WEB SITE: WWW.BANJOCORP.COM
E-MAIL: BANJOSALES@IDEXCORP.COM

DESCRIPTION
1" FEMALE COUPLING x 1" FEMALE BSP THREAD

PART NUMBER
100DB