

Parts List			
ITEM	QTY	PART NUMBER	DESCRIPTION
1	1	100DECAL	Mini Coupling Decal
2	1	100G	1" & 1 1/4" COUPLING GASKET
3	2	100K	1" CAM ARM W/ RING
4	2	100P	PIN
5	1	125CXM	1" Female Coupler x 1 1/4" HB, Machined

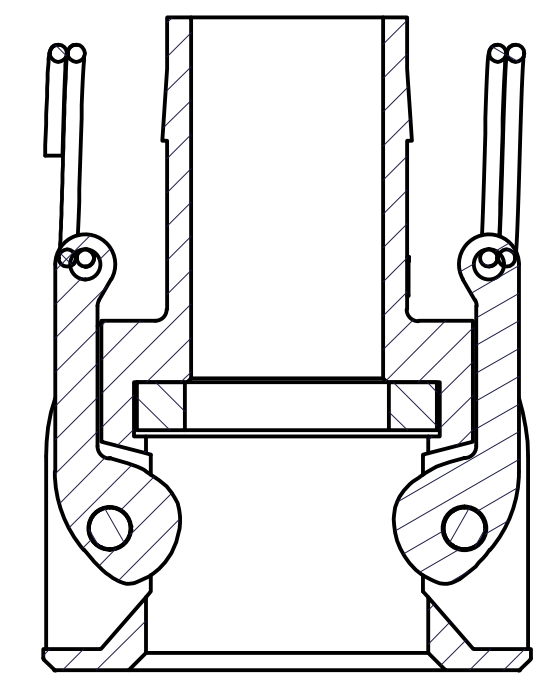
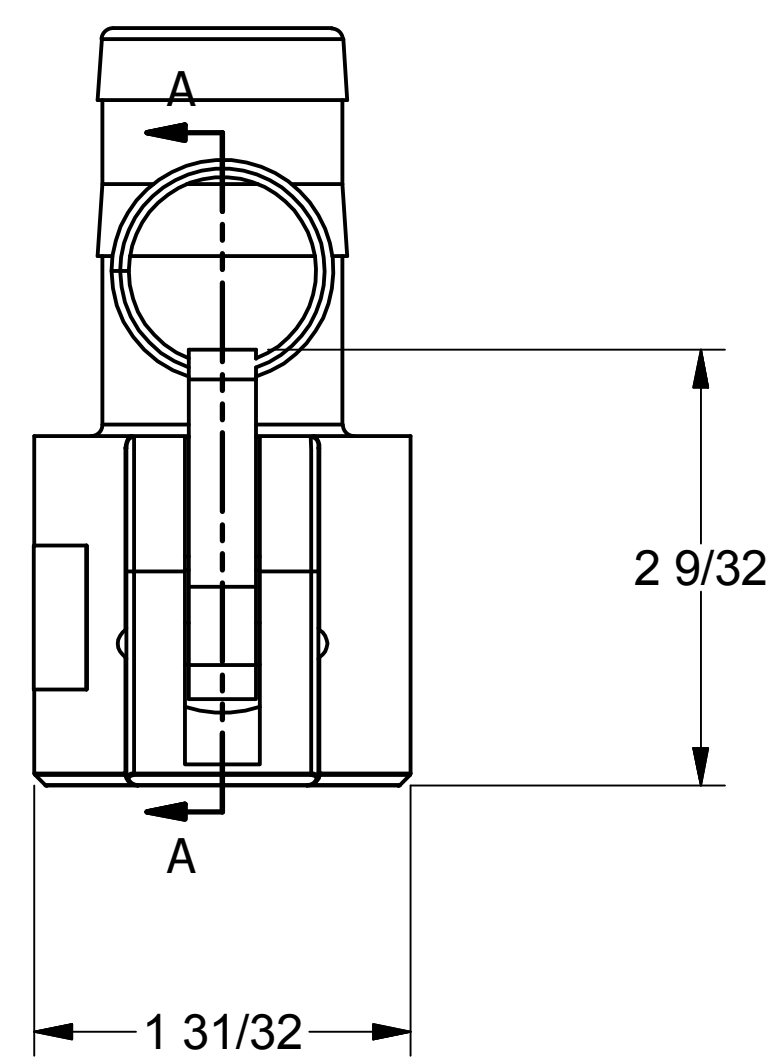
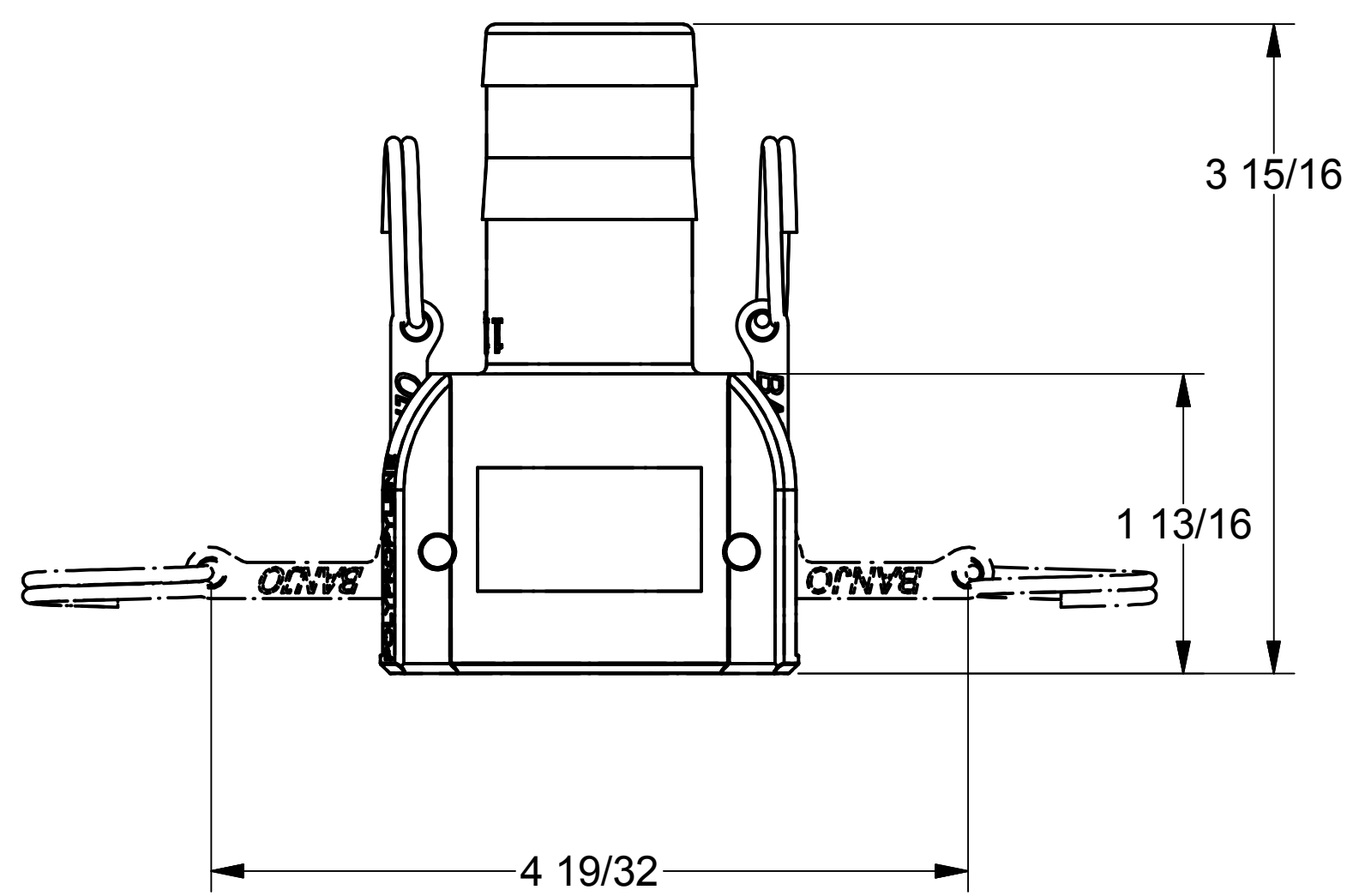
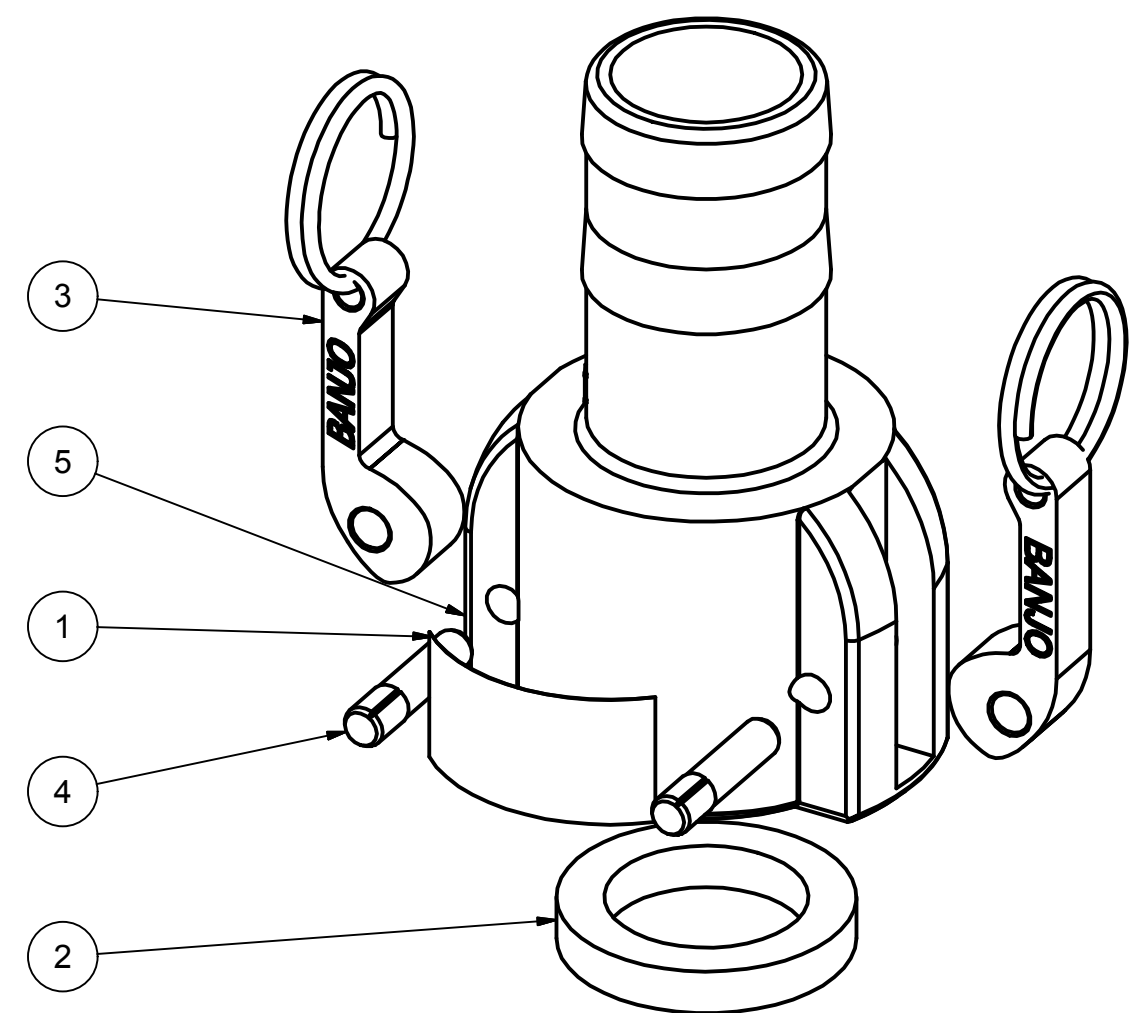

SECTION A-A
SCALE 1 : 1

Note: Parts are to be bagged.

THIS DRAWING AND ALL INFORMATION CONTAINED THEREON ARE THE EXCLUSIVE PROPERTY OF BANJO CORPORATION.

UNLESS SPECIFICALLY NOTED, THIS DRAWING AND ITEMS SHOWN ON THIS DRAWING ARE SUBJECT TO CHANGE AT ANY TIME.

BANJO CORPORATION
 150 BANJO DRIVE, CRAWFORDSVILLE, IN 47933
 WEB SITE: WWW.BANJOCORP.COM
 E-MAIL: SALES1@BANJOCORP.COM

DESCRIPTION
1" Female Coupler x 1 1/4" HB

PART NUMBER
125C