

Parts List			
ITEM	QTY	PART NUMBER	DESCRIPTION
1	1	100DECAL	Mini Coupling Decal
2	1	100G	1" & 1 1/4" COUPLING GASKET
3	2	100K	1" CAM ARM W/ RING
4	2	100P	PIN
5	1	125DXM	1" Female Coupler x 1 1/4" Female NPT, Machined

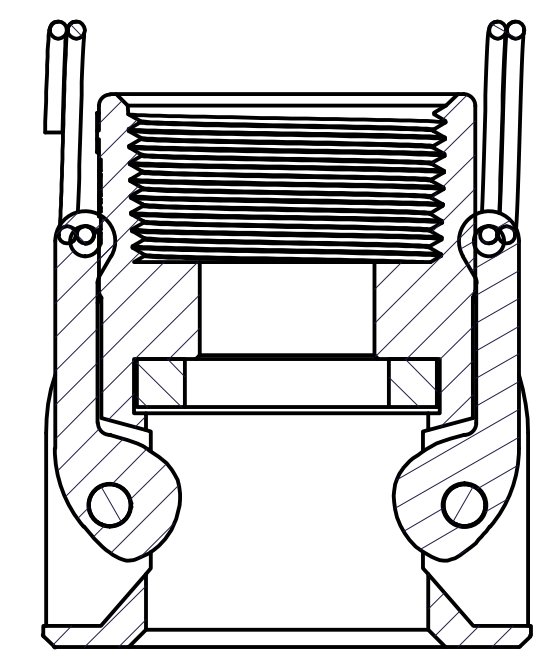
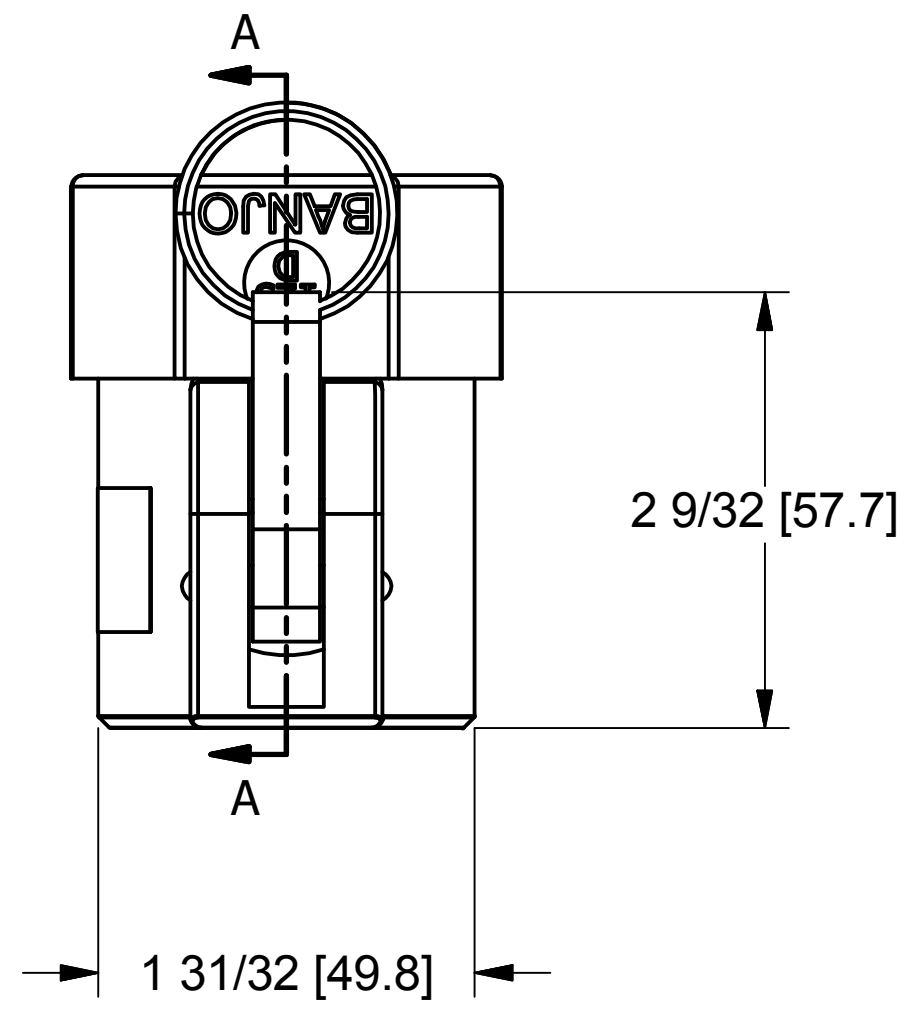
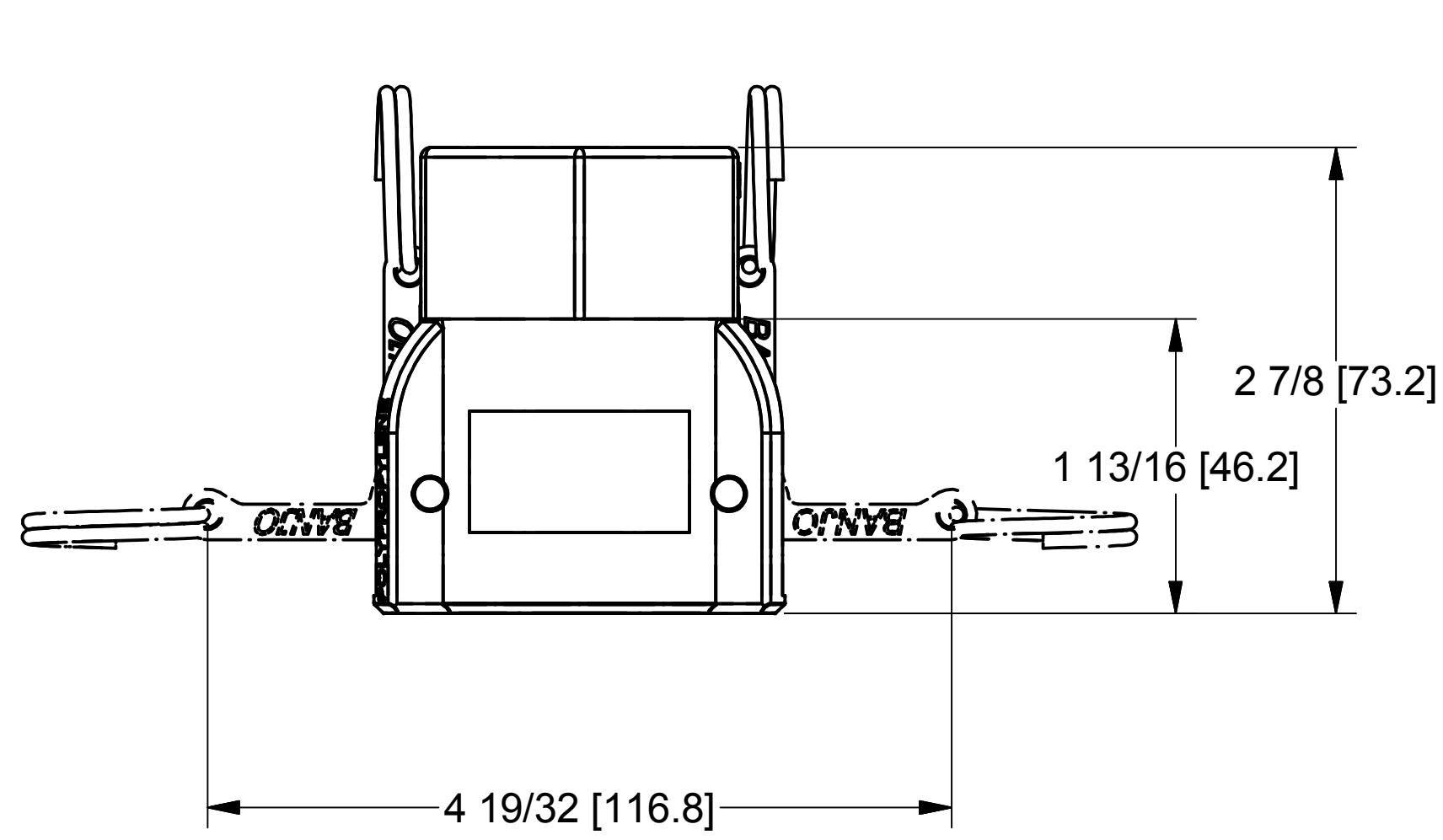
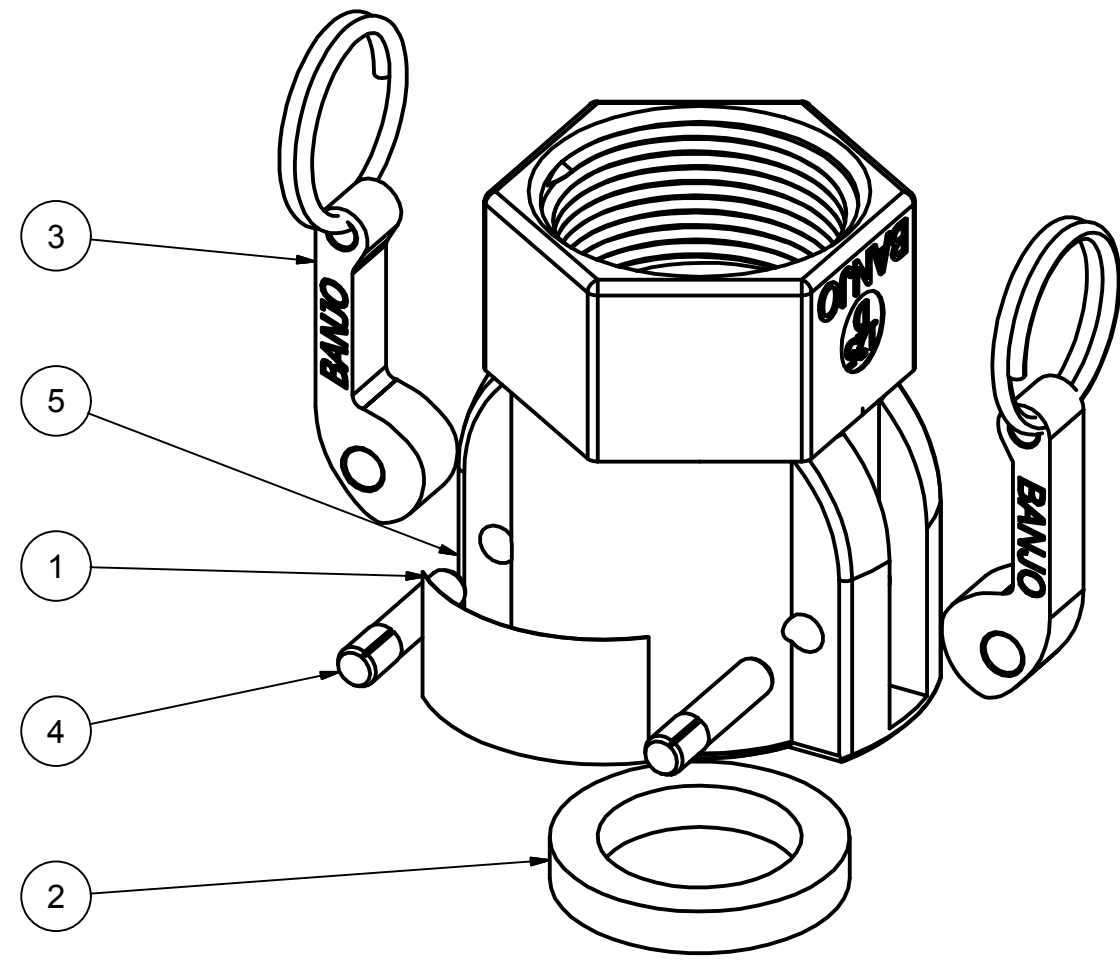

SECTION A-A  
SCALE 1 : 1

Note: Parts are to be bagged.

THIS DRAWING AND ALL INFORMATION CONTAINED THEREON ARE THE EXCLUSIVE PROPERTY OF BANJO CORPORATION.

UNLESS SPECIFICALLY NOTED, THIS DRAWING AND ITEMS SHOWN ON THIS DRAWING ARE SUBJECT TO CHANGE AT ANY TIME.

**BANJO CORPORATION**  
 150 BANJO DRIVE, CRAWFORDSVILLE, IN 47933  
 WEB SITE: WWW.BANJOCORP.COM  
 E-MAIL: SALES1@BANJOCORP.COM

DESCRIPTION  
**1" Female Coupler x 1 1/4" Female NPT**

PART NUMBER  
**125D**