

4

3

2

1

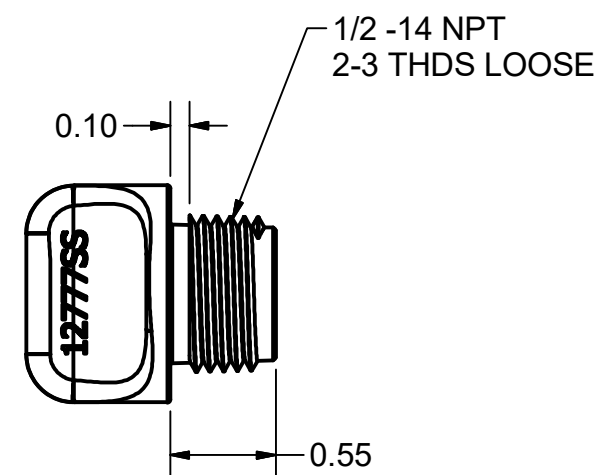
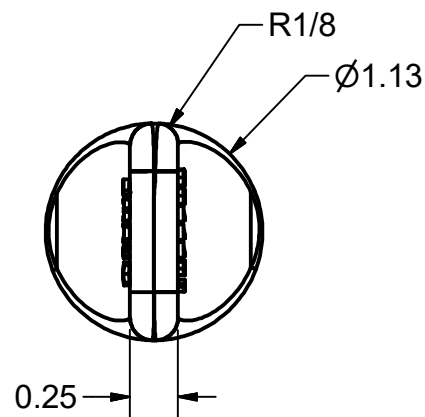
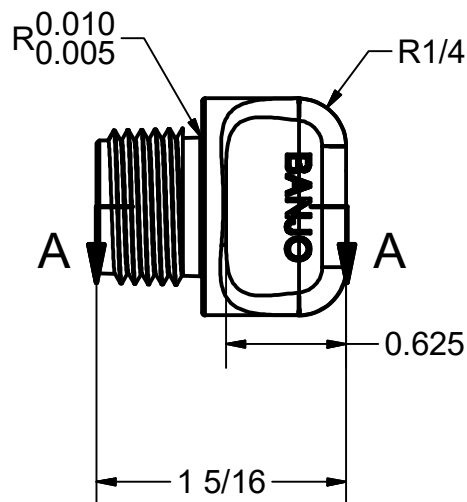
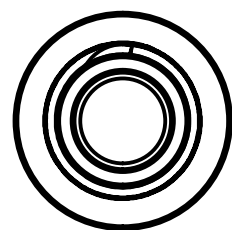
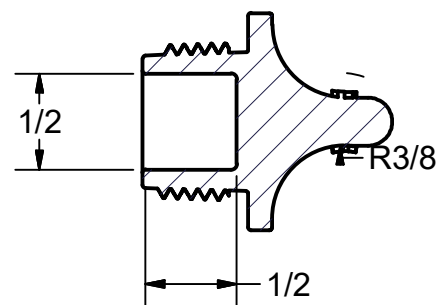
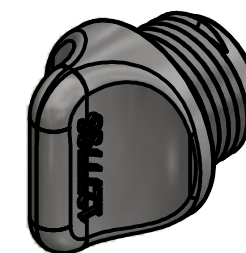

NOTES:

MATL: 316 SS

TOLERANCE UNLESS OTHERWISE SPECIFIED DECIMALS 0.00 = +/- 0.010 DECIMALS 0.000 = +/- 0.005 FRACTIONS 1/X = +/- 1/32 ANGLES = +/- 1 BREAK ALL SHOWN CORNERS W/ 1/32 R UNLESS OTHERWISE SPECIFIED				
DRAWN MJC CHECKED QA MFG APPROVED MJC		<b>BANJO CORPORATION</b> 150 BANJO DRIVE, CRAWFORDSVILLE, IN 47933 TITLE <b>1/2" DRAIN PLUG</b>		
		SIZE B SCALE	DWG TYPE ENG DWG NO 12777SS	REV 000 SHEET 1 OF 2

4

3

2

1