

Parts List			
ITEM	QTY	PART NUMBER	DESCRIPTION
1	1	150(200)D	CAM LEVER COUPLING DECAL
2	2	150(200)K	1 1/2" & 2" CAM ARM
3	1	150G	1 1/2" Coupling Gasket
4	1	150XC	1 1/2" Male Coupling X 1 1/2" Barb
5	2	200P	CAM ARM PIN

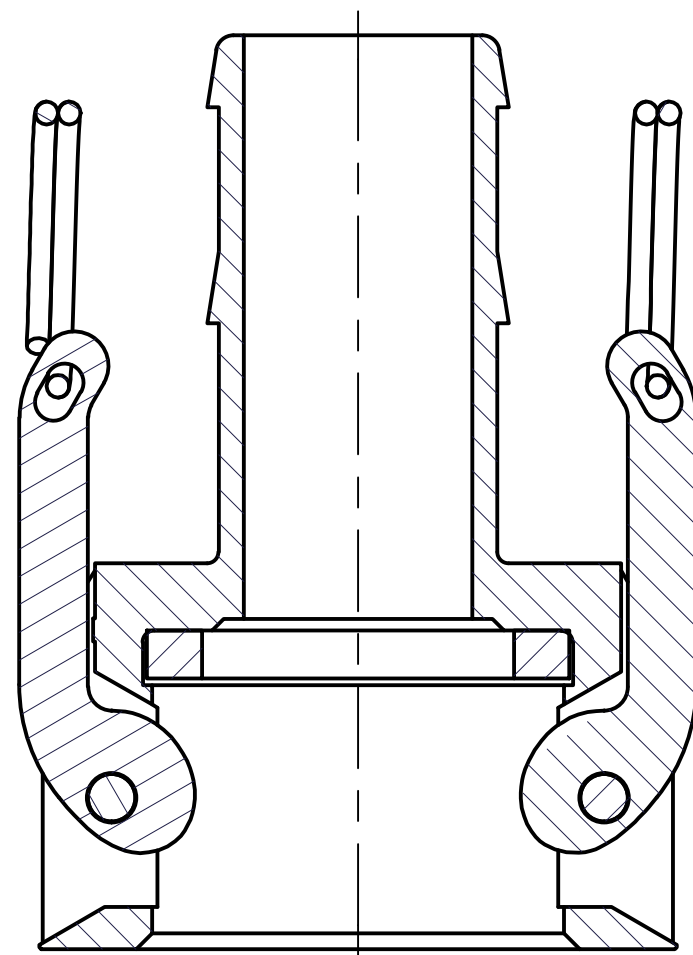

SECTION A-A
SCALE 1 : 1

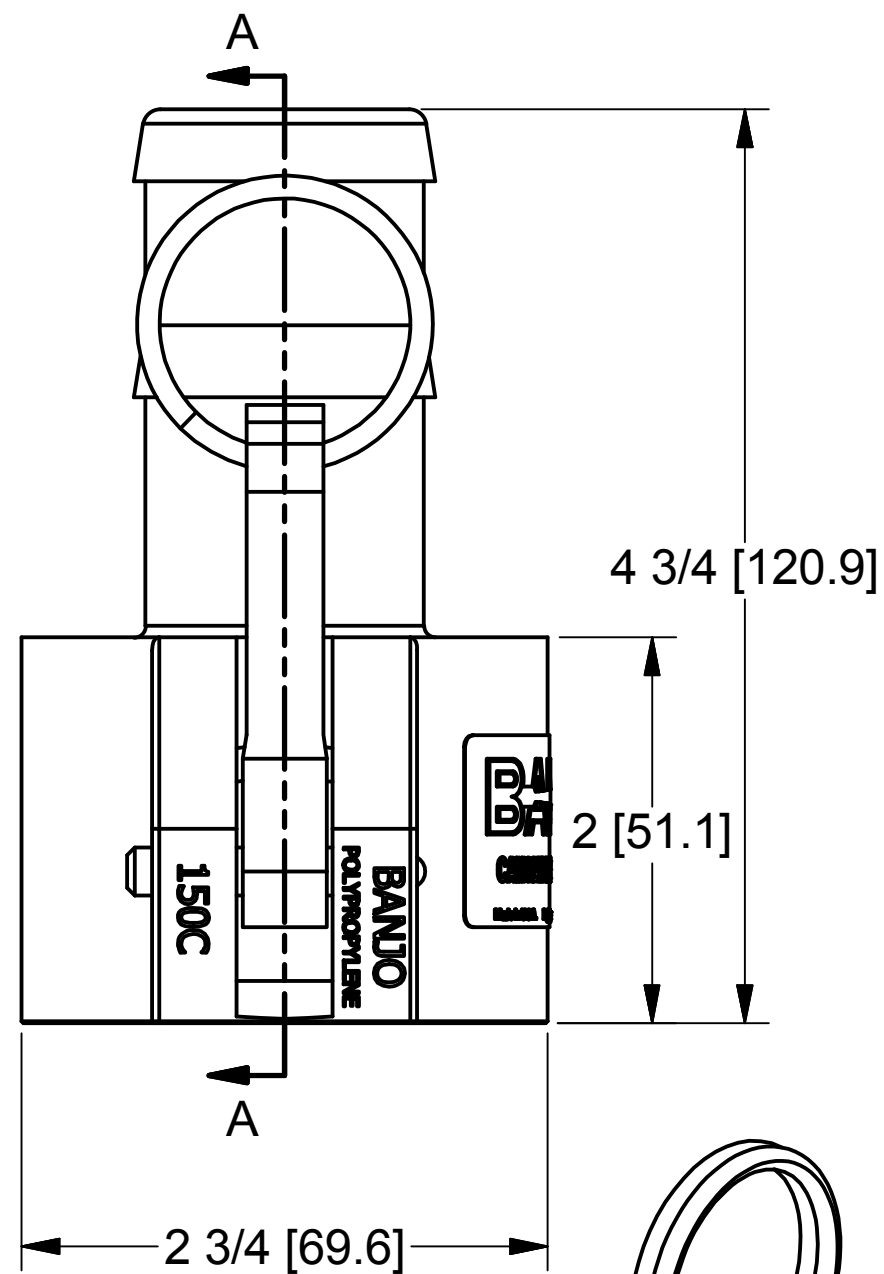
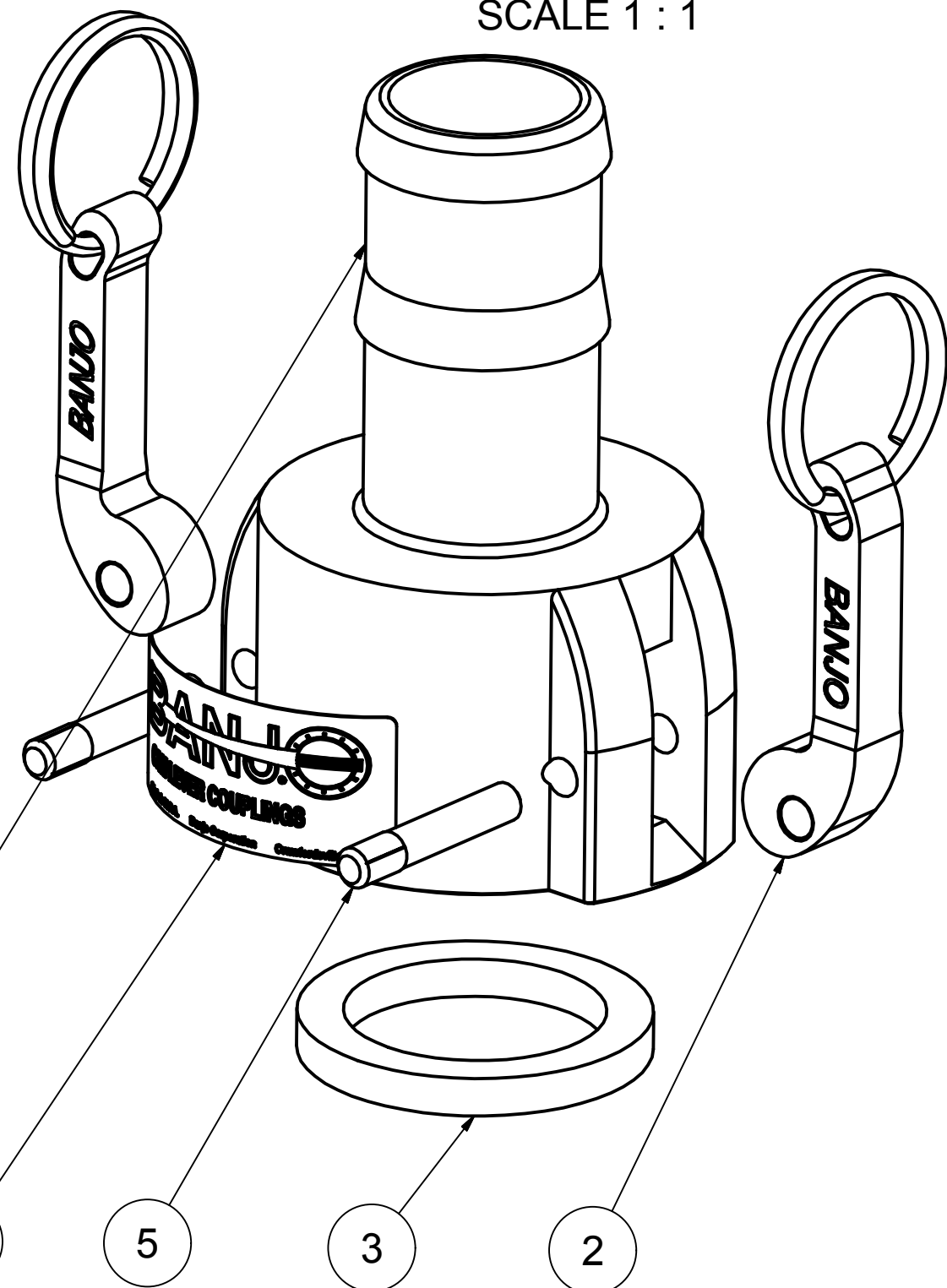
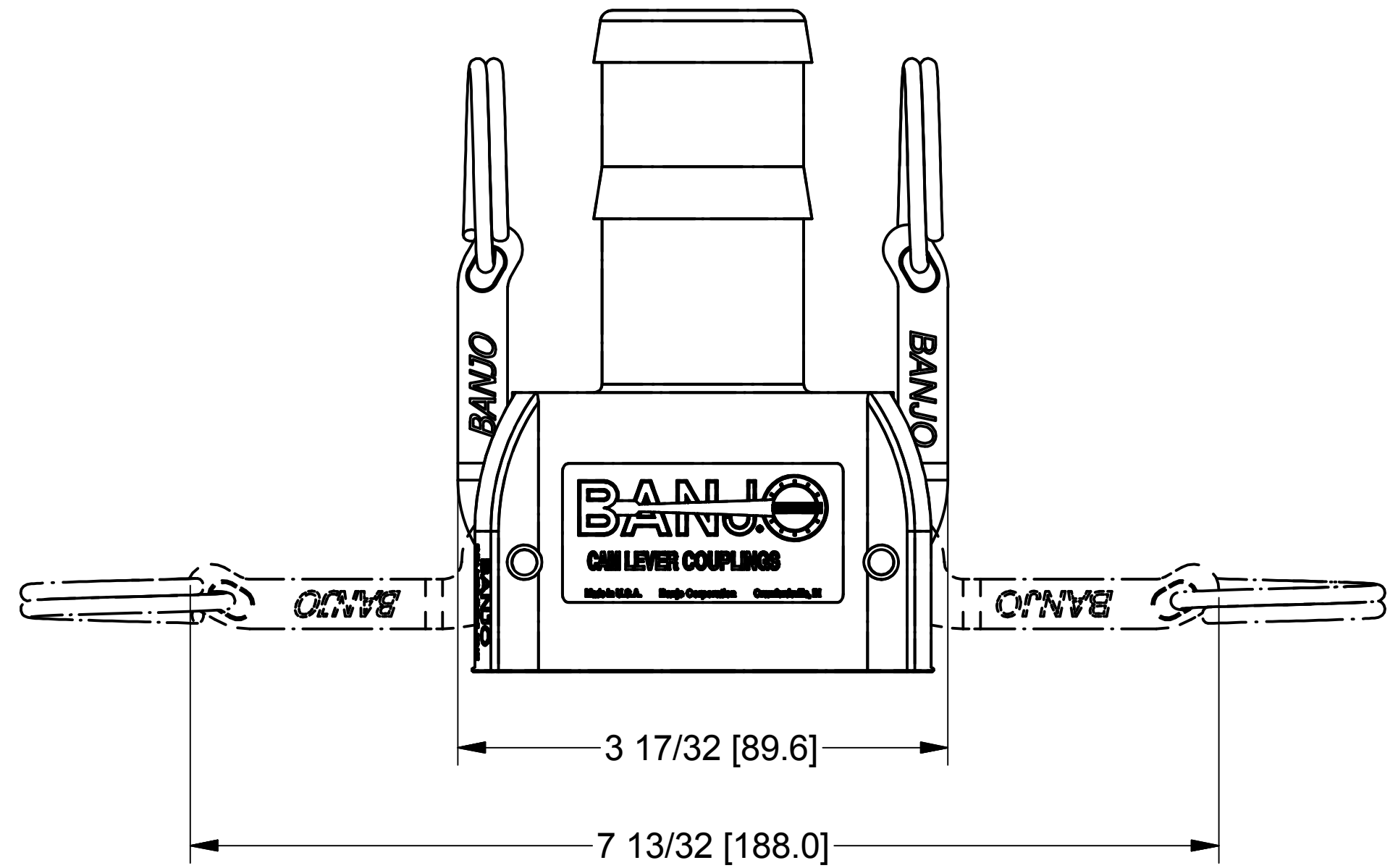

BANJO CORPORATION
 150 BANJO DRIVE, CRAWFORDSVILLE, IN 47933
 WEB SITE: WWW.BANJOCORP.COM
 E-MAIL: SALES1@BANJOCORP.COM

THIS DRAWING AND ALL INFORMATION CONTAINED THEREON ARE THE EXCLUSIVE PROPERTY OF BANJO CORPORATION.

UNLESS SPECIFICALLY NOTED, THIS DRAWING AND ITEMS SHOWN ON THIS DRAWING ARE SUBJECT TO CHANGE AT ANY TIME.

DESCRIPTION
 1 1/2" Female Coupler x 1 1/2" HB

PART NUMBER
 150C