

Parts List			
ITEM	QTY	PART NUMBER	DESCRIPTION
1	1	150(200)D	CAM LEVER COUPLING DECAL
2	2	150(200)K	1 1/2" & 2" CAM ARM
3	1	150G	1 1/2" Coupling Gasket
4	1	150XCAP	1 1/2" Cap, Molded
5	2	200P	CAM ARM PIN

D
C
B
A

D
C
B
A

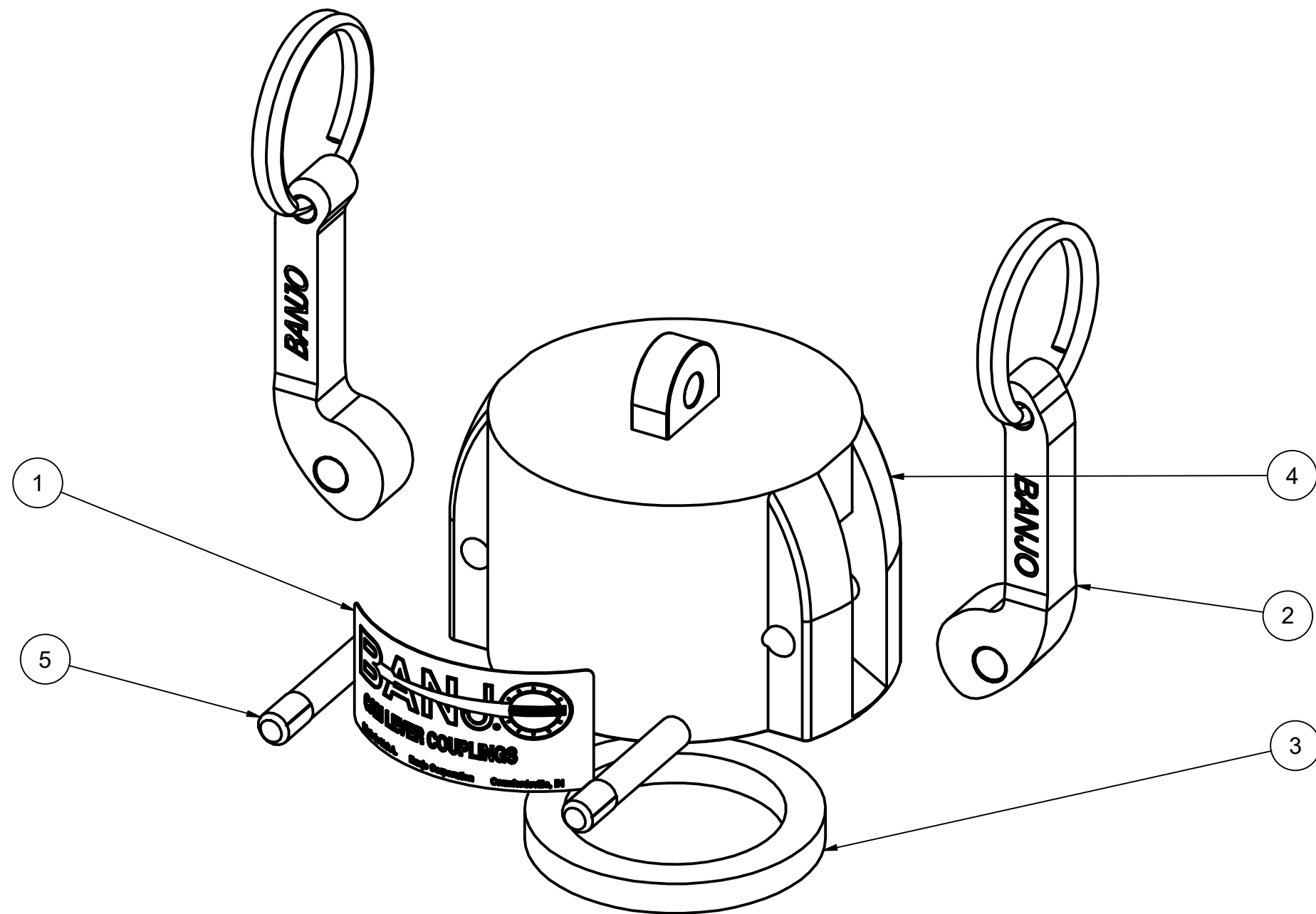
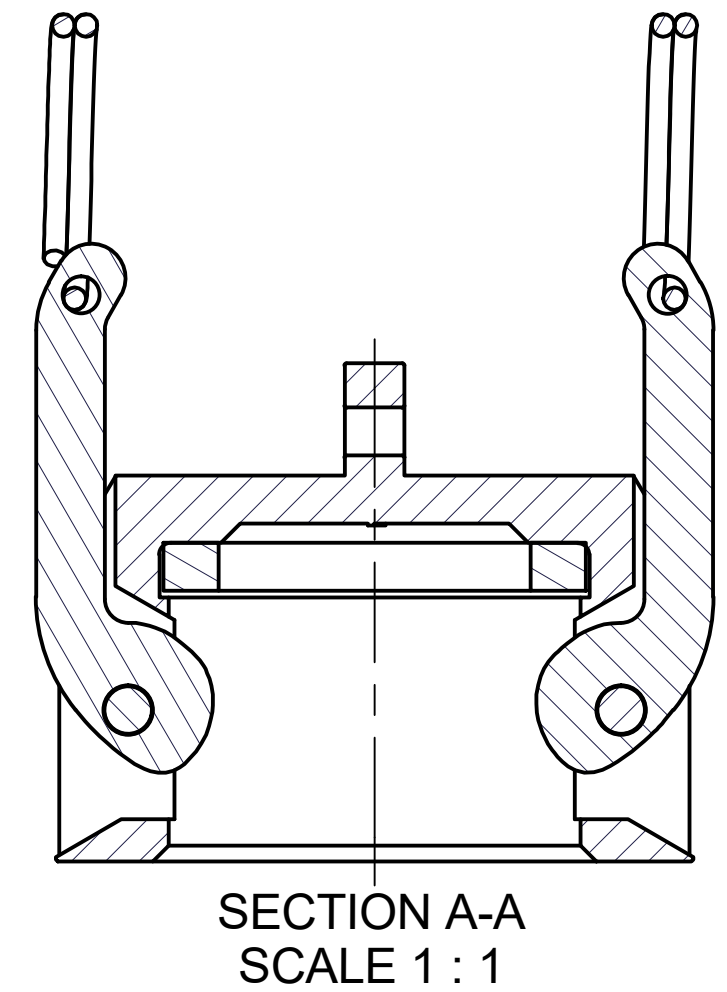
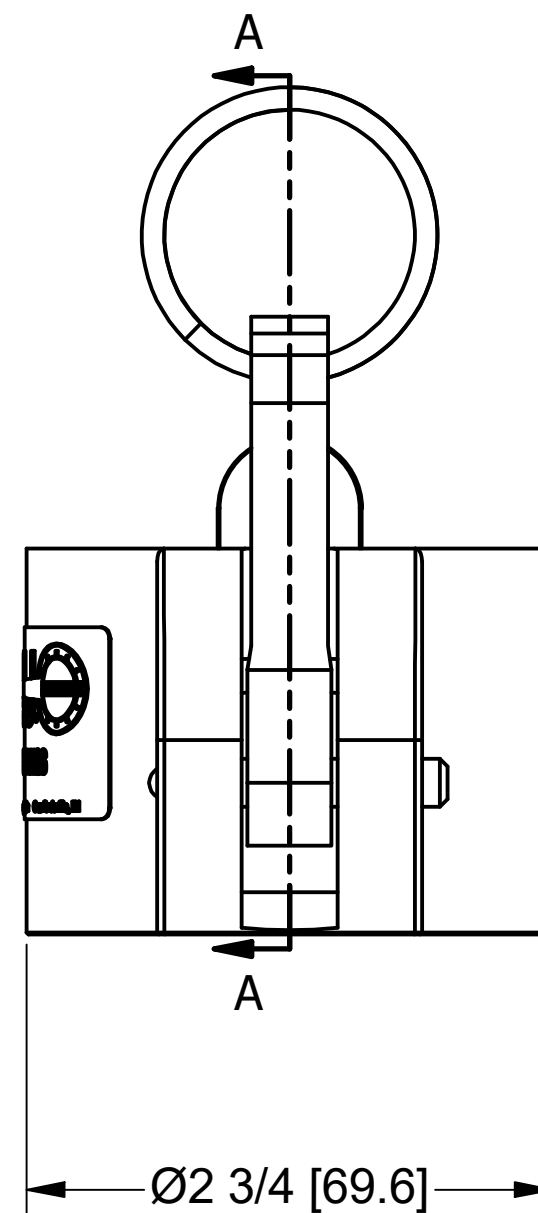
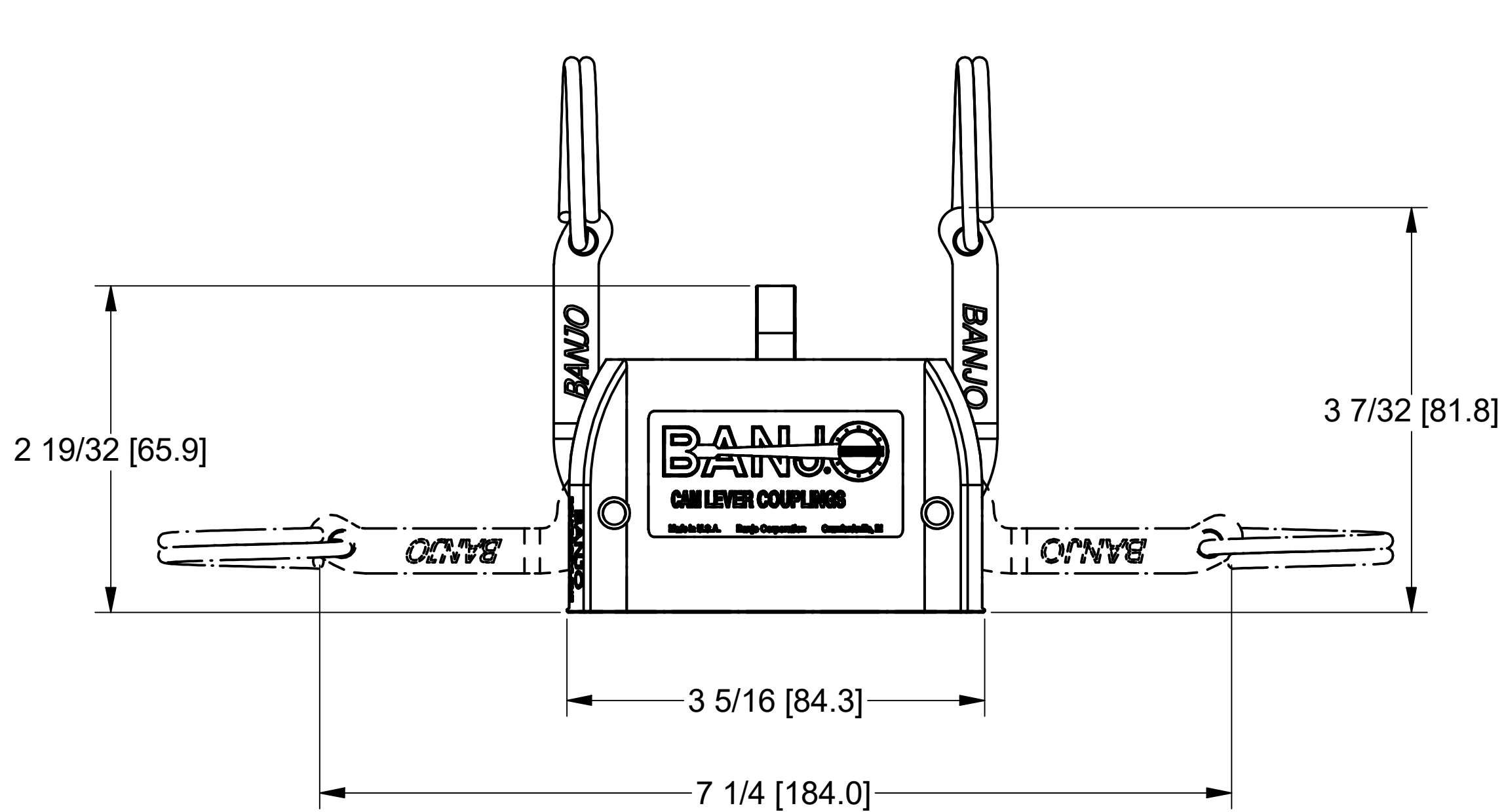

THIS DRAWING AND ALL INFORMATION CONTAINED THEREON ARE THE EXCLUSIVE PROPERTY OF BANJO CORPORATION.

UNLESS SPECIFICALLY NOTED, THIS DRAWING AND ITEMS SHOWN ON THIS DRAWING ARE SUBJECT TO CHANGE AT ANY TIME.



BANJO CORPORATION
150 BANJO DRIVE, CRAWFORDSVILLE, IN 47933
WEB SITE: WWW.BANJOCORP.COM
E-MAIL: BANJOSALES@IDEXCORP.COM

DESCRIPTION	1 1/2" Cap
PART NUMBER	150CAP

4

3

2

1