

Parts List			
ITEM	QTY	PART NUMBER	DESCRIPTION
1	1	150(200)D	CAM LEVER COUPLING DECAL
2	2	150(200)K	1 1/2" & 2" CAM ARM
3	1	150G	1 1/2" Coupling Gasket
4	1	150XD-90	1 1/2" Female Coupling X 90° 1 1/2" Female NPT, Molded
5	2	200P	CAM ARM PIN

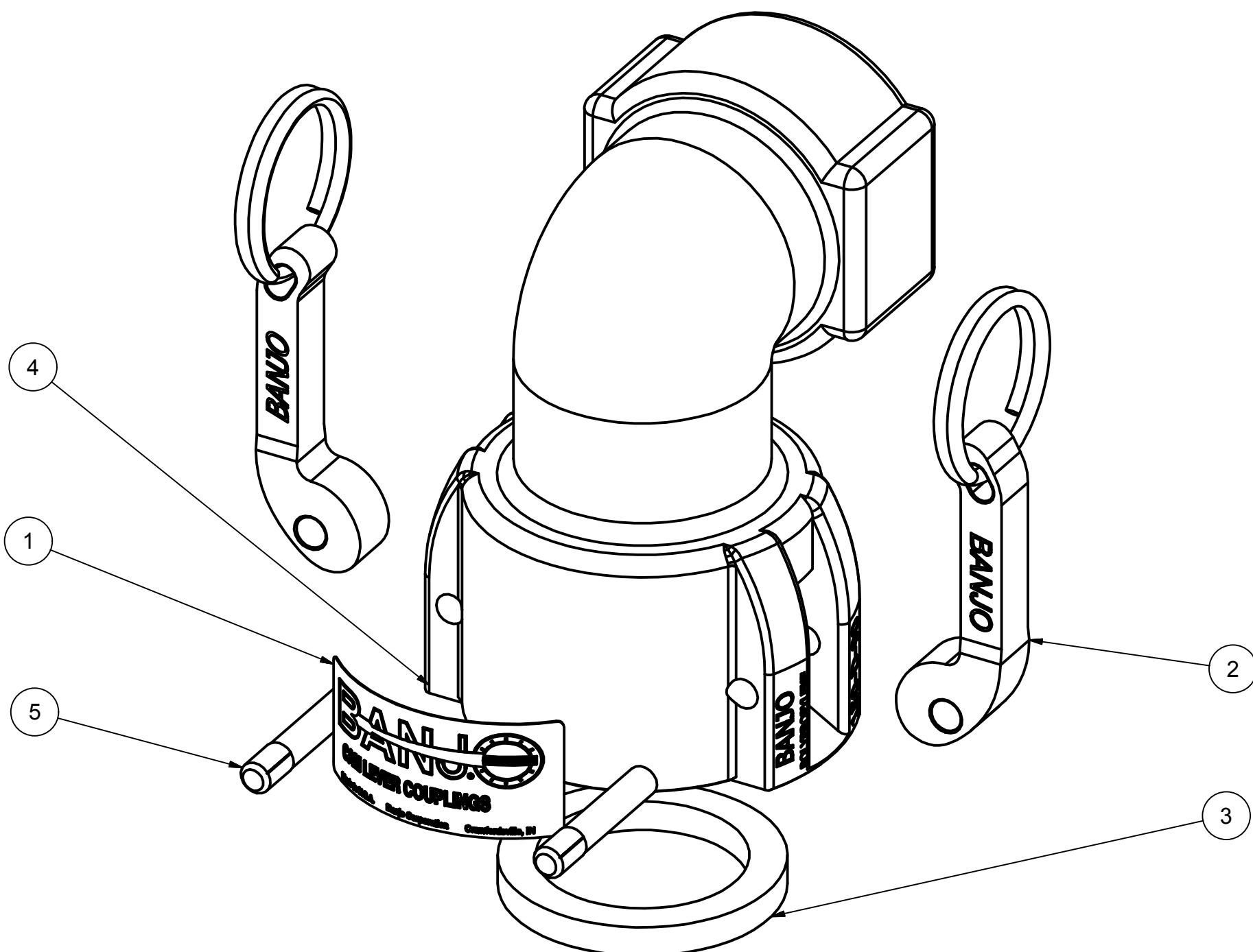
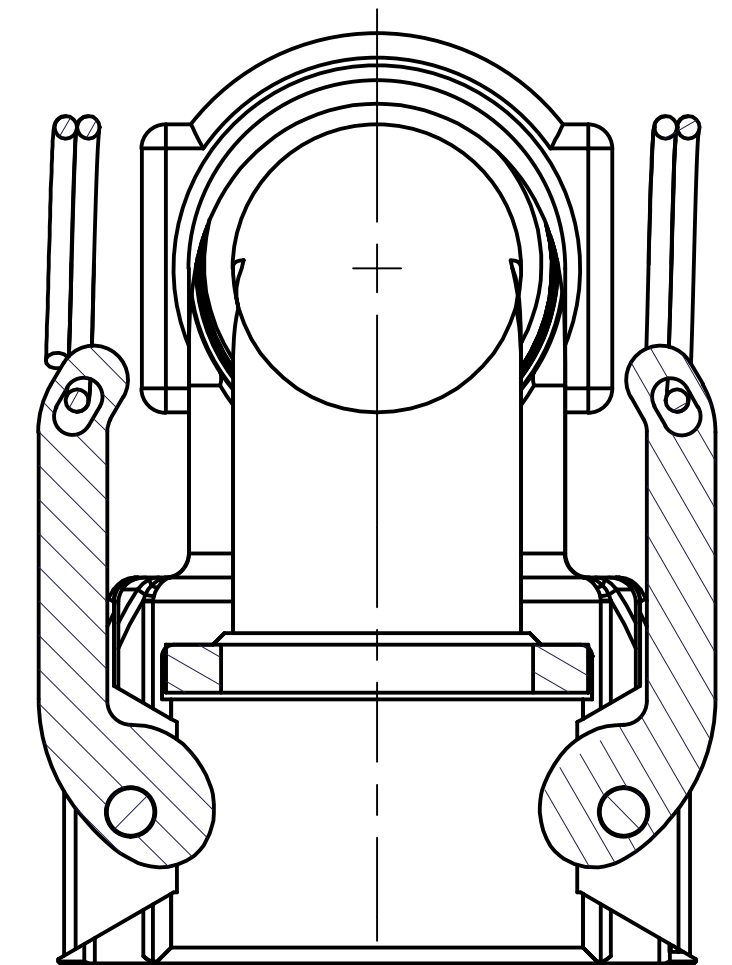
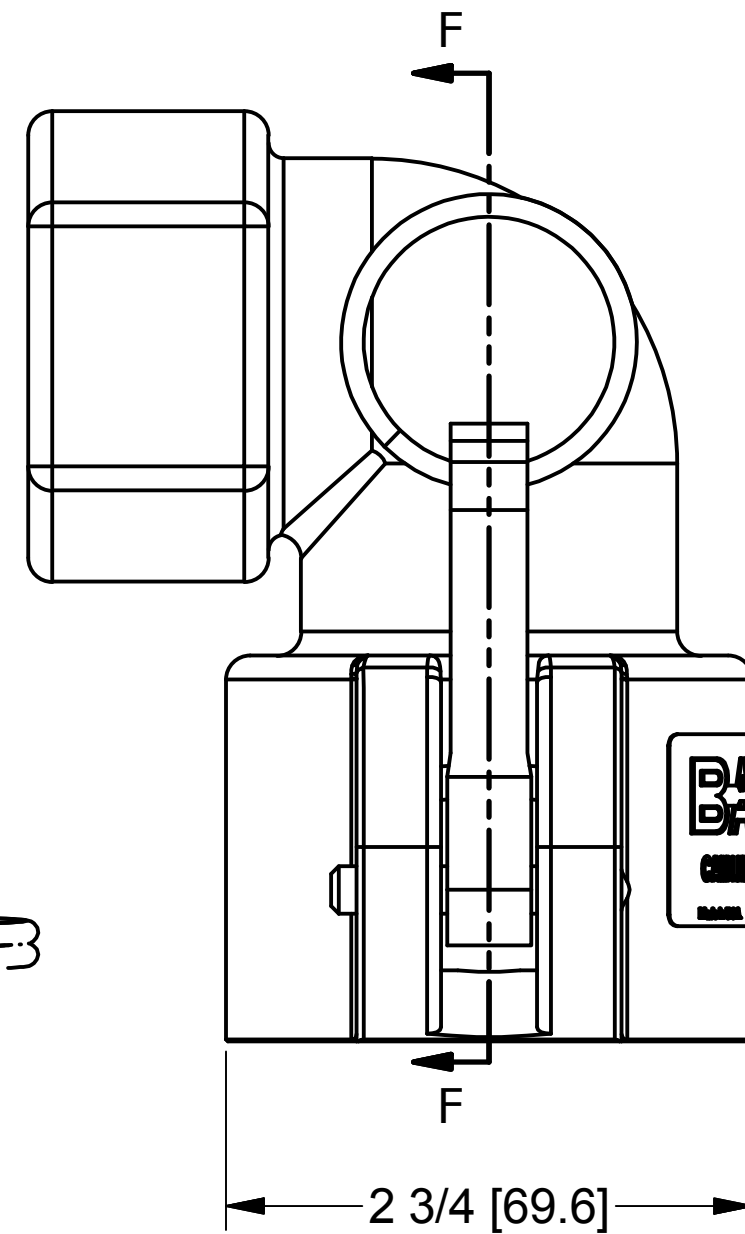
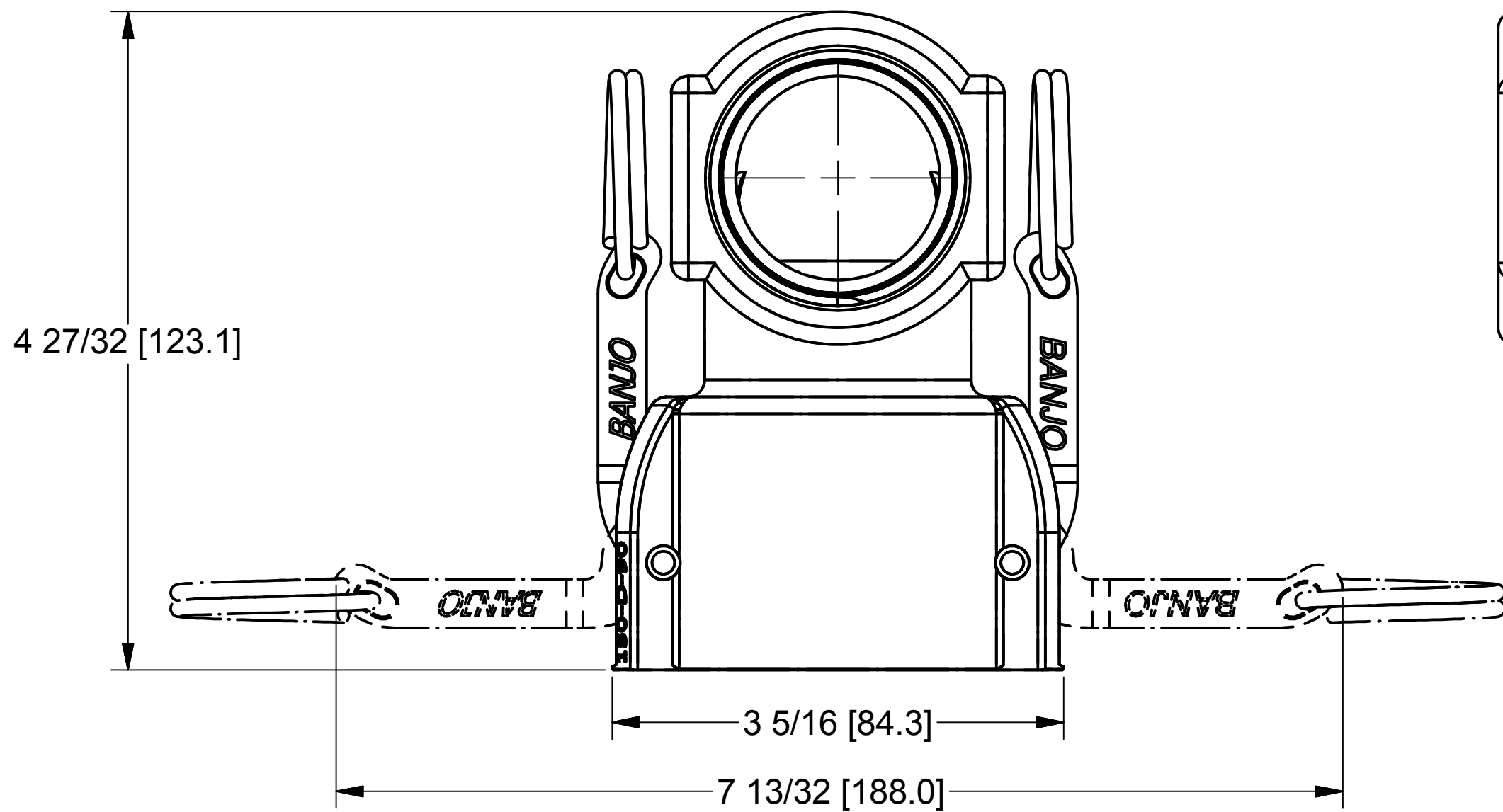

THIS DRAWING AND ALL INFORMATION CONTAINED THEREON ARE THE EXCLUSIVE PROPERTY OF BANJO CORPORATION.

UNLESS SPECIFICALLY NOTED, THIS DRAWING AND ITEMS SHOWN ON THIS DRAWING ARE SUBJECT TO CHANGE AT ANY TIME.

BANJO CORPORATION  
 150 BANJO DRIVE, CRAWFORDSVILLE, IN 47933  
 WEB SITE: WWW.BANJOCORP.COM  
 E-MAIL: BANJOSALES@IDEXCORP.COM

DESCRIPTION  
**1 1/2" Female Coupling X 90° 1 1/2" Female NPT**

PART NUMBER  
**150D90**