

Parts List			
ITEM	QTY	PART NUMBER	DESCRIPTION
1	1	150(200)D	CAM LEVER COUPLING DECAL
2	2	150(200)K	1 1/2" & 2" CAM ARM
3	1	150G	1 1/2" Coupling Gasket
4	1	150XDB	1 1/2" Female Coupling X 1 1/2" Female BSPT, Molded
5	2	200P	CAM ARM PIN

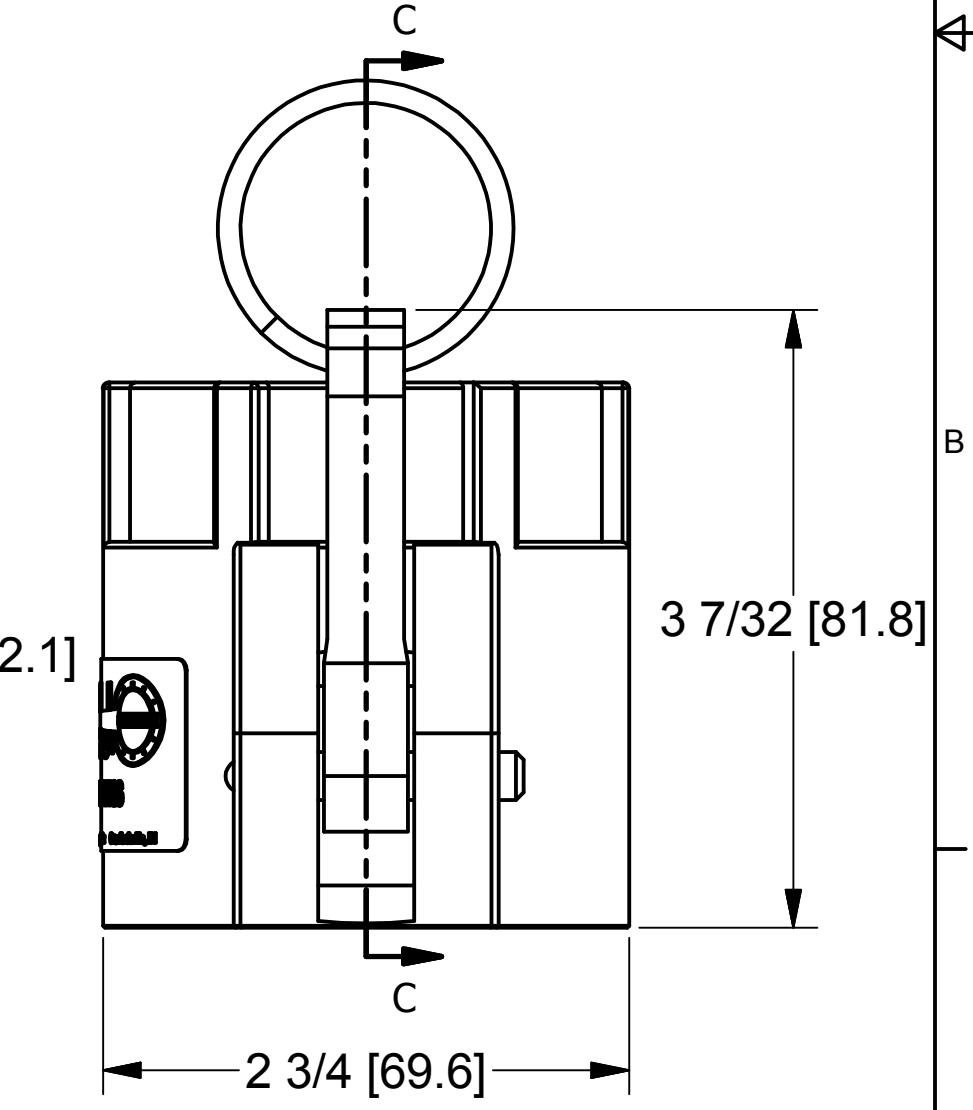
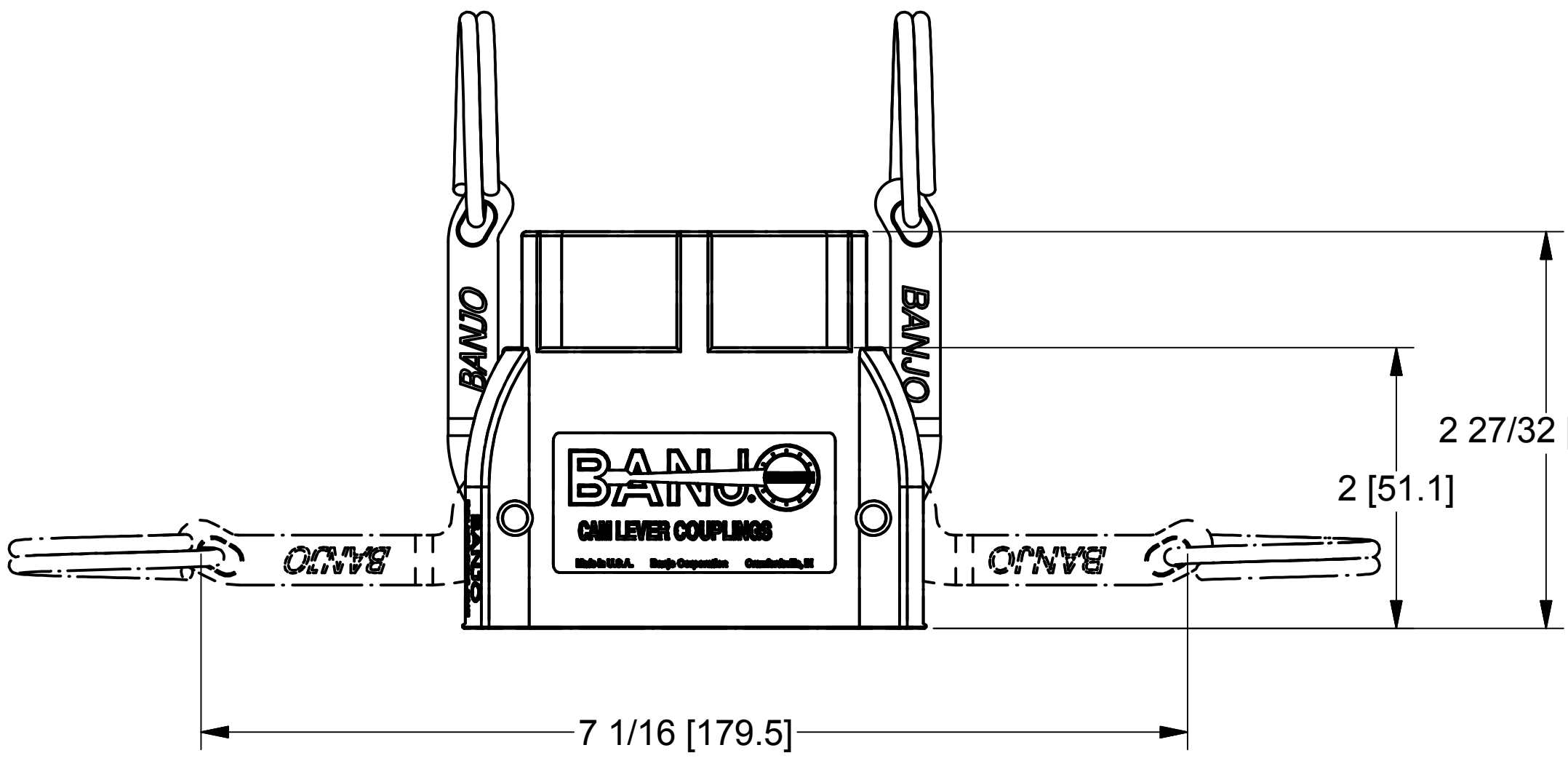
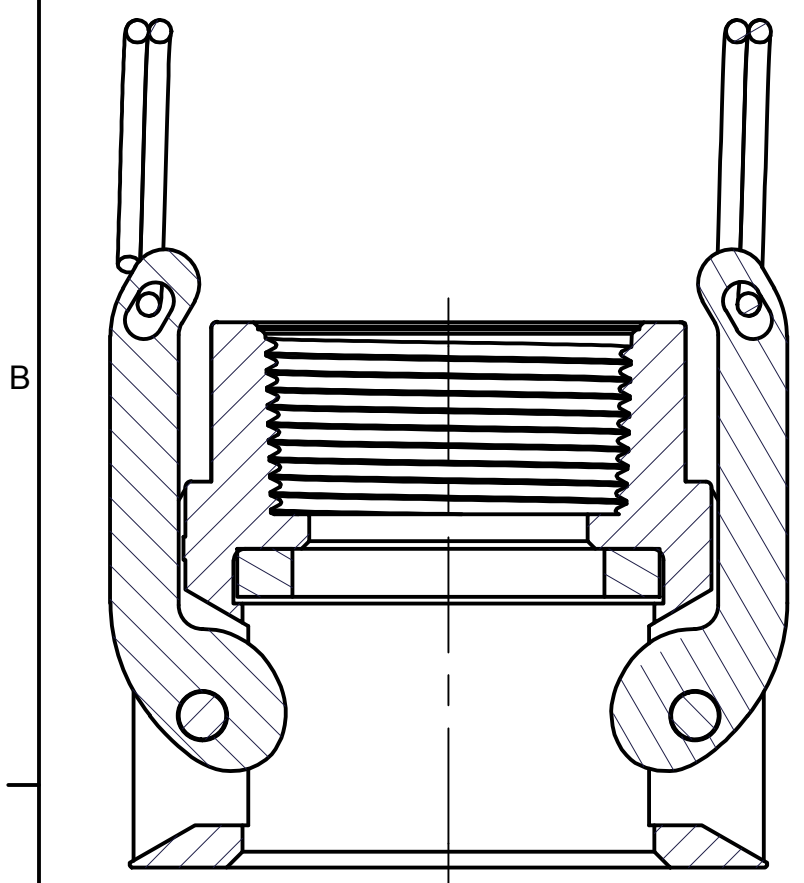
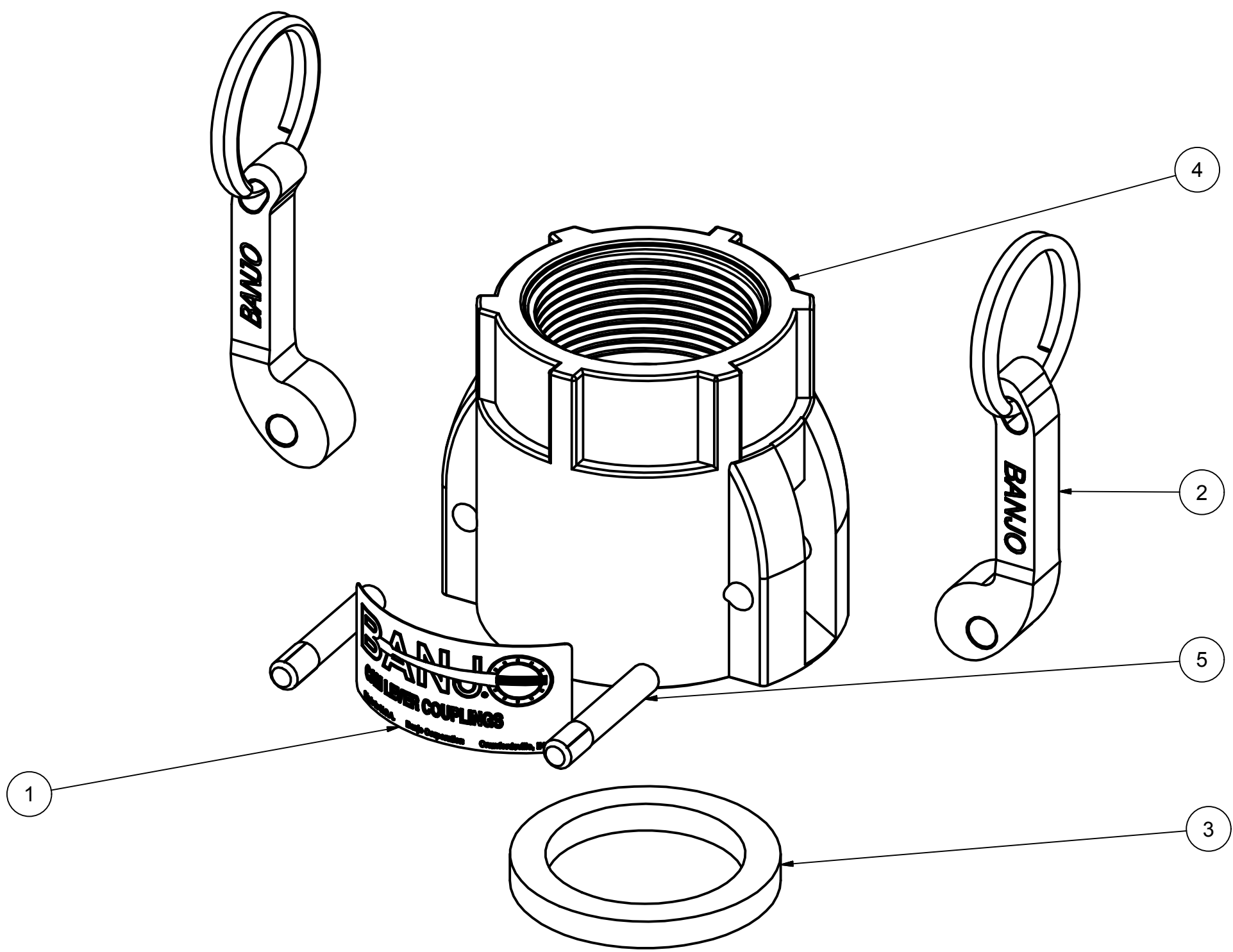

<small>TOLERANCE UNLESS OTHERWISE SPECIFIED DECIMALS 0.00 = +/- 0.010 DECIMALS 0.000 = +/- 0.005 FRACTIONS 1/X = +/- 1/32 ANGLES = +/- 1 BREAK ALL SHOWN CORNERS W/ 1/32 R UNLESS OTHERWISE SPECIFIED</small>		
<small>DRAWN</small> ALR	<small>DATE</small> 7/20/1999	
BANJO CORPORATION 150 BANJO DRIVE, CRAWFORDSVILLE, IN 47933		<small>TITLE</small> 1 1/2" Female Coupling X 1 1/2" Female BSPT
<small>SCALE</small> C	<small>DWG NO</small> 150DB	
<small>SIZE</small> C	<small>DWG TYPE</small> ENG	<small>REV</small> SHEET 2 OF 4