

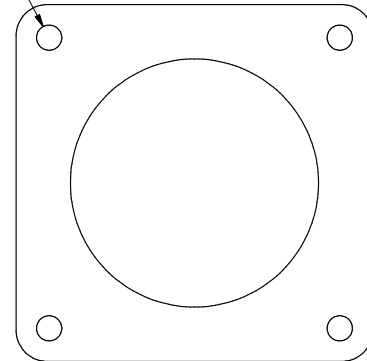

Ø13/32 THRU, 4 PLCS
ON A 6 5/8" B.C.



NOTE:
DO NOT SCALE PRINT
MATL: CLASS 25 GRAY CI

TOLERANCE UNLESS OTHERWISE SPECIFIED		
DECIMALS 0.00 = +/- 0.010 DECIMALS 0.000 = +/- 0.005 FRACTIONS 1/8 = +/- 1/32 ANGLES = +/- 1°		
BREAK ALL SHOWN CORNERS W/ 1/32 R UNLESS OTHERWISE SPECIFIED		BANJO CORPORATION 150 BANJO DRIVE, CRAWFORDSVILLE, IN 47933
DRAWN	MJC	3/19/2007
CHECKED		
QA		
MFG		
APPROVED		
TITLE		4" OUTLET FLANGE
SIZE	DWG TYPE	DWG NO
D	ENG	16000
SCALE		SHEET 1 OF 1