

CAST PART NO., ARROW,
& "ROTATION" AS SHOWN,
3/8" NUMERALS, 7/16" LETTERS

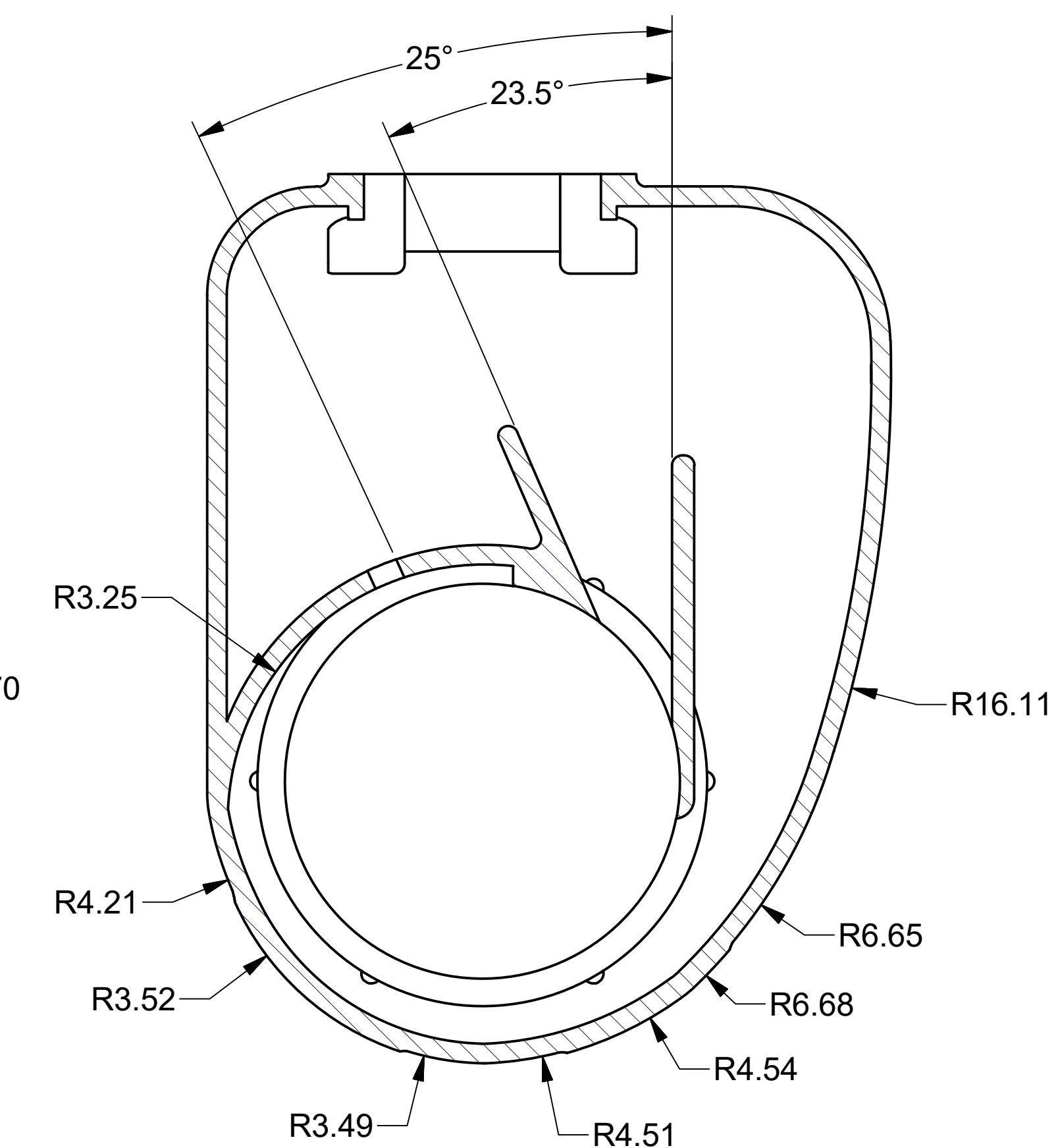
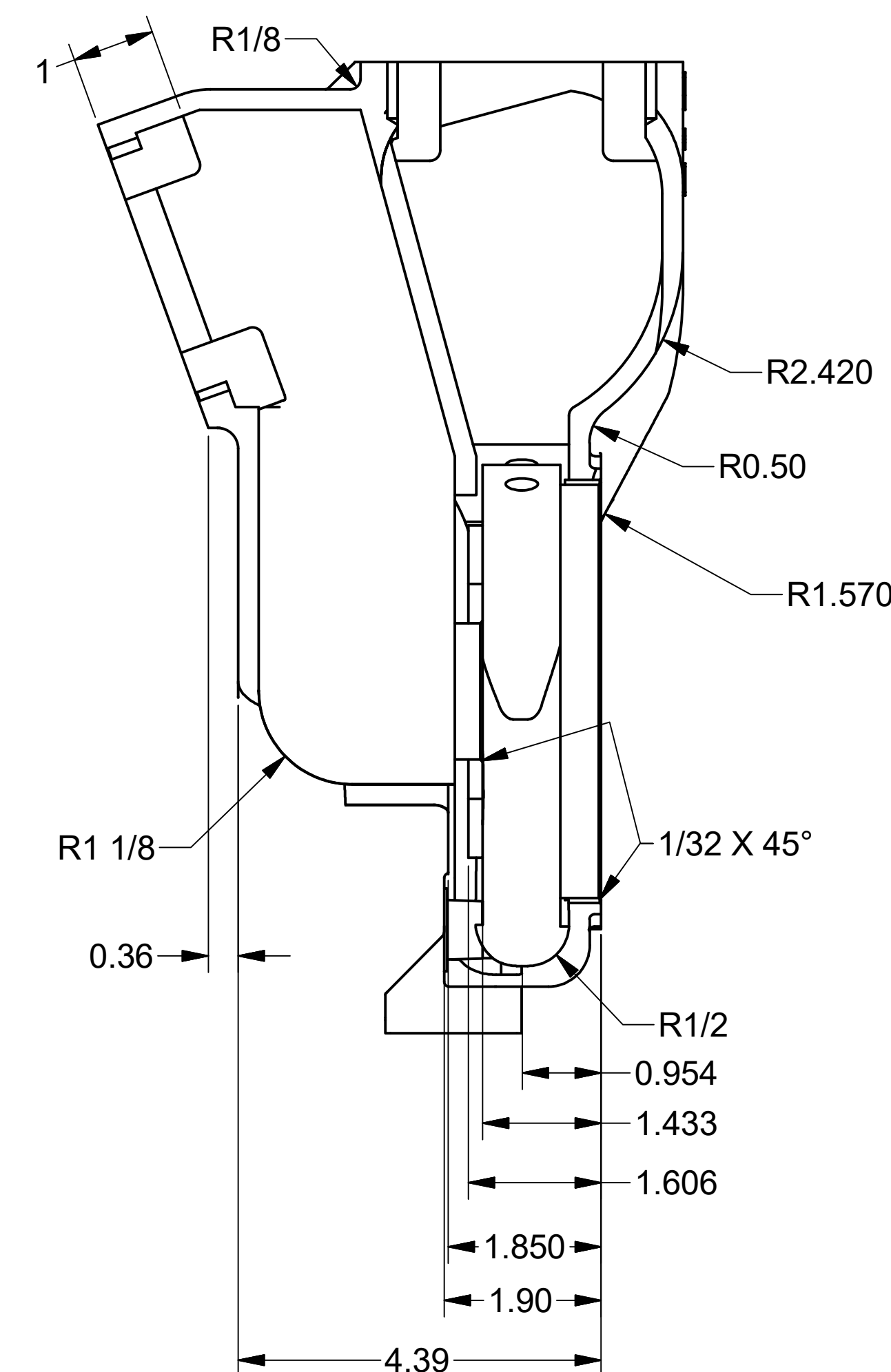
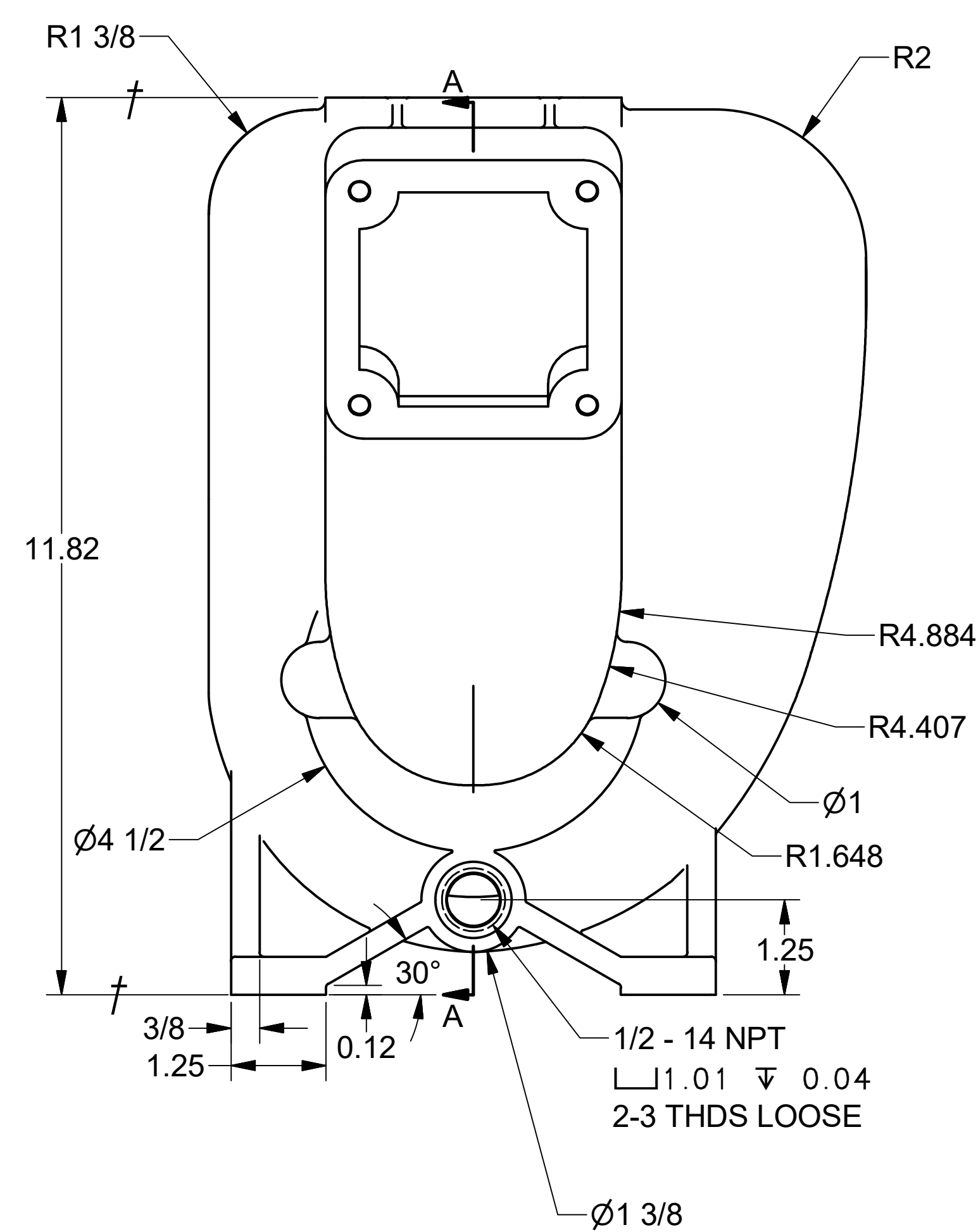
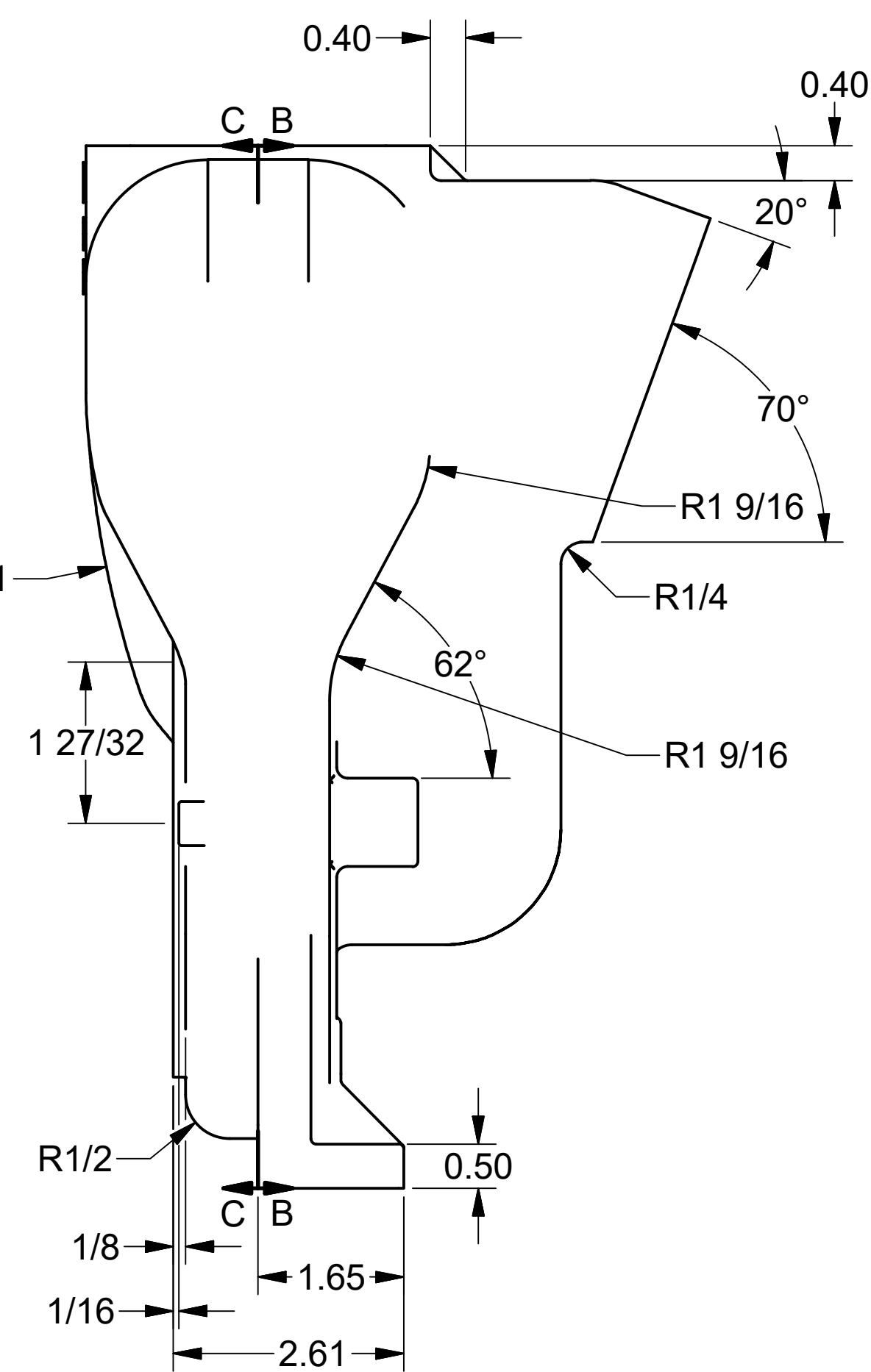
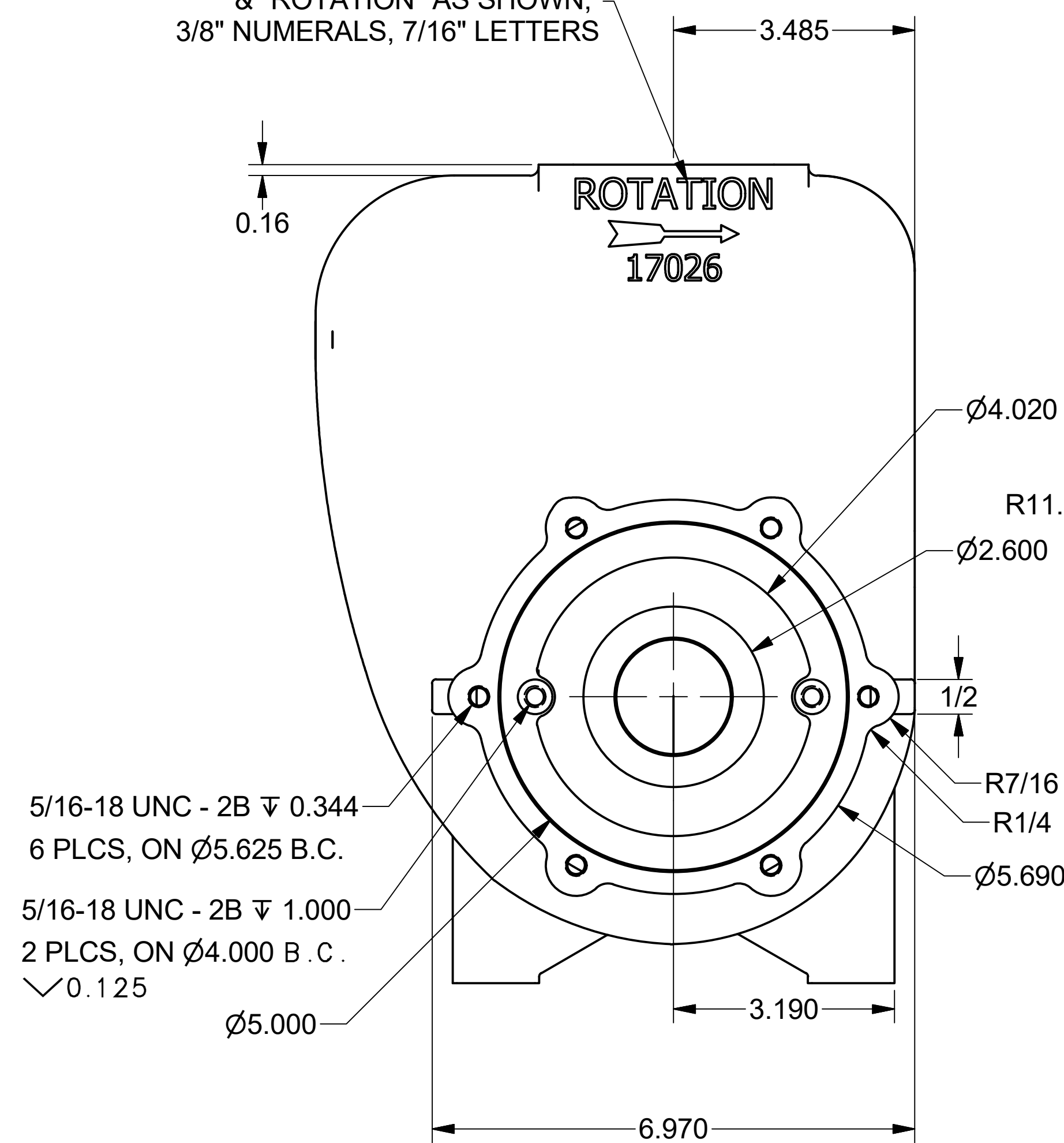

NOTES:
DO NOT SCALE PRINT
WALL THICKNESS TO BE 1/4" TYP.
BREAK ALL OUTSIDE CORNERS W/ R1/16" U.O.S.
ANGLES TOL. ±1/2 U.O.S.
FINISHED SURFACES ARE INDICATED BY †
FINISH TO BE 63-125 RMS. LAY TO BE NORMAL TO TECHNIQUE USED
USE R1/8 ON ALL FILLETS AND BOSSES U.O.S.
FINISH TO BE FLAT BLACK PAINT. MASK ALL MACHINED SURFACES BEFORE PAINTING
PRESSURE TEST CASTING TO 100 PSI
MATL: GRAY CAST IRON 25-35M TENSILE

REVISION HISTORY				
ZONE	REV	DESCRIPTION	DATE	APPROVED
	1	MOVED TO INVENTOR	5/10/2007	MJC
D7	1A	ADDED 1/8" COUNTERSINKS	5/16/2007	MJC
D4	2	CHANGED DRAIN PLUG	9/08/08	MJC

TOLERANCE UNLESS OTHERWISE SPECIFIED	
DECIMALS 0.00 = ±0.0010	
DECIMALS 0.000 = ±0.0005	
FRACTIONS 1/8 = ±1/32	
ANGLES = ±1°	
BREAK ALL SHOWN CORNERS W/ 1/32 R UNLESS OTHERWISE SPECIFIED	
DRAWN	MJC
CHECKED	5/2/2007
QA	
MFG	



BANJO CORPORATION
150 BANJO DRIVE, CRAWFORDSVILLE, IN 47933

TITLE
2" PUMP HOUSING

SIZE DWG TYPE DWG NO
E ENG 17026

REV 000