

Parts List			
ITEM	QTY	PART NUMBER	DESCRIPTION
1	1	200G	2" Coupling Gasket
2	2	200P	CAM ARM PIN
3	2	150(200)K	1 1/2" & 2" CAM ARM
4	1	200XB90	2" Female Coupler x 90 Deg Male Threads molded
5	1	150(200)D	Decal

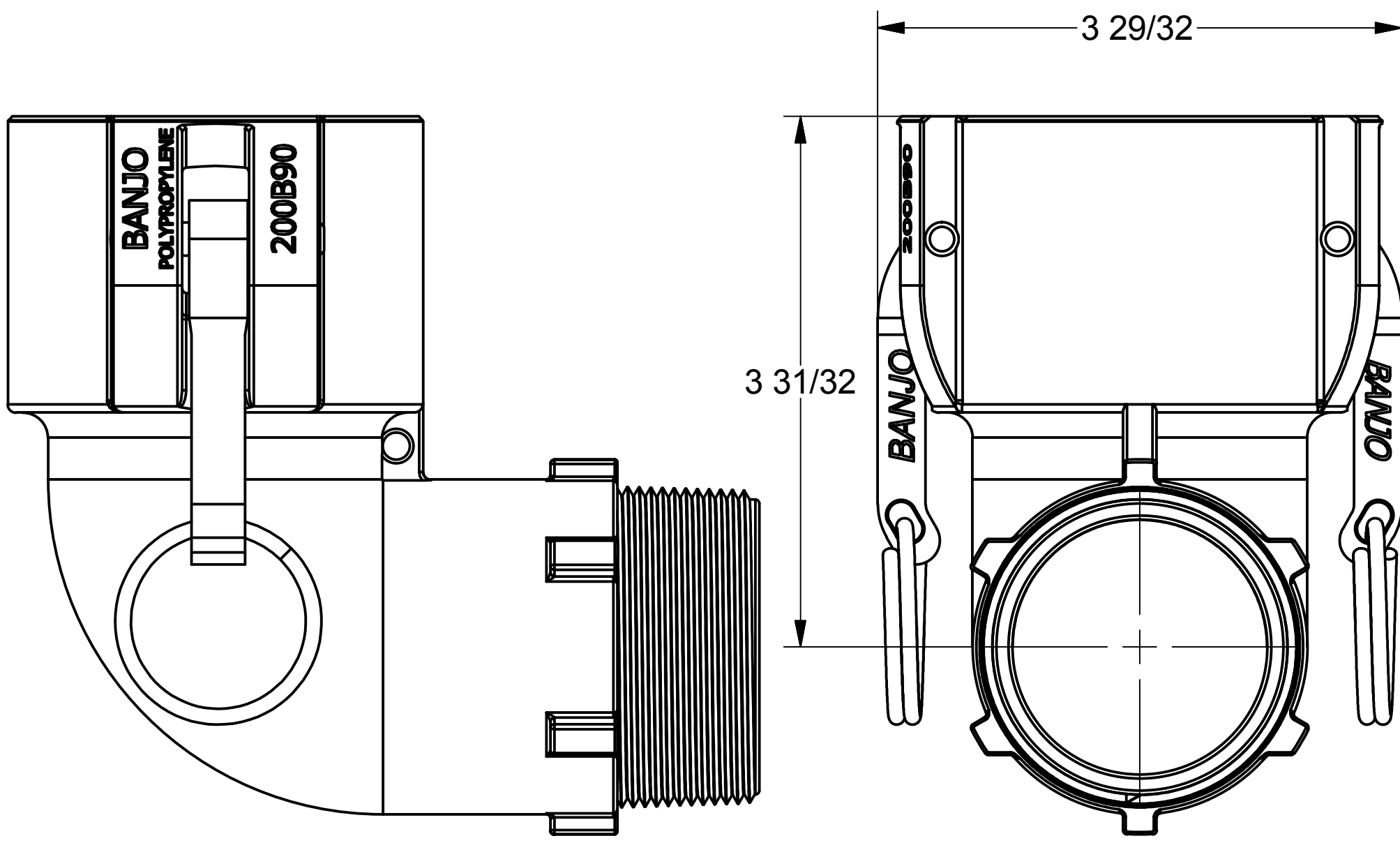
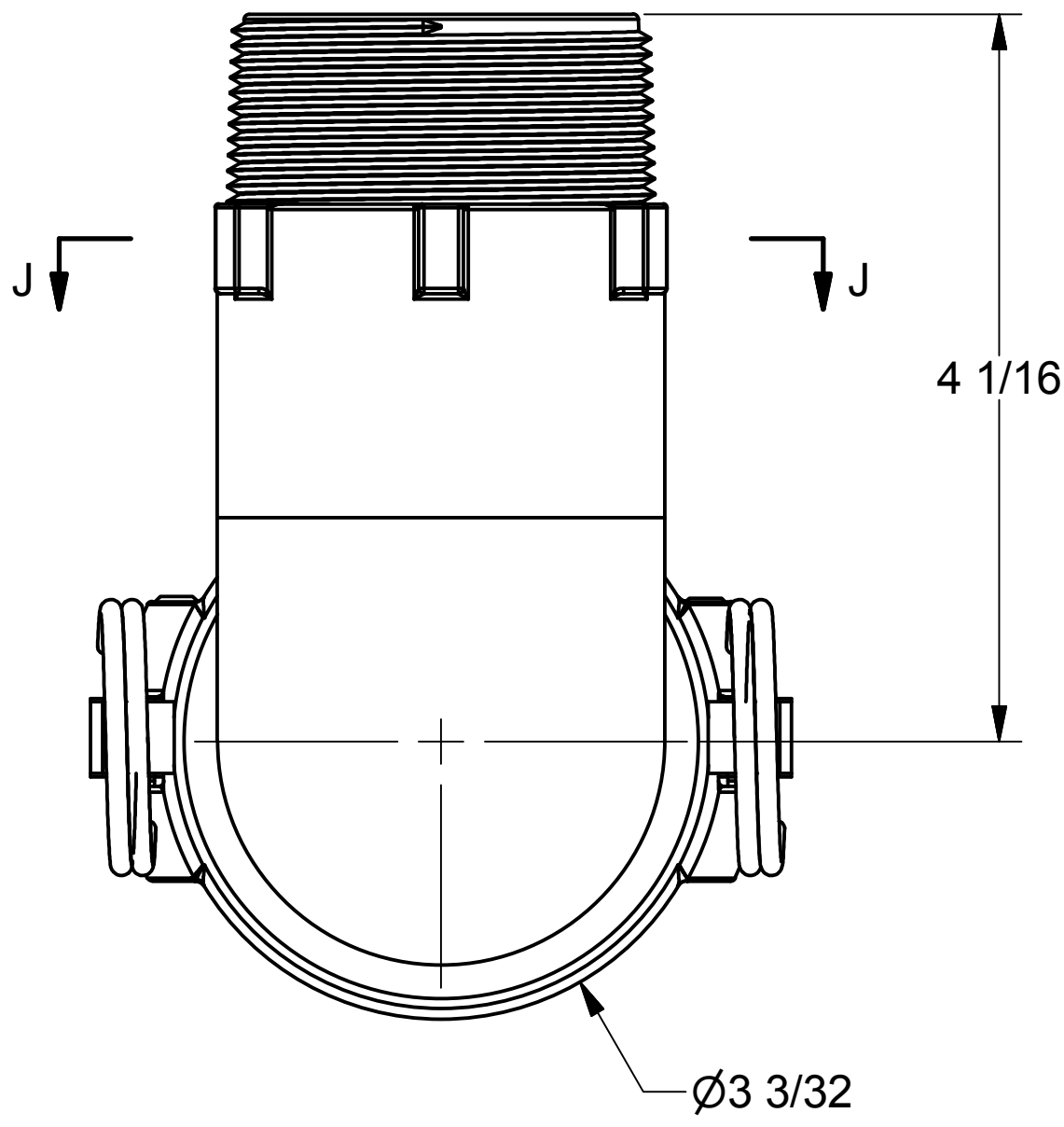

THIS DRAWING AND ALL INFORMATION CONTAINED THEREON ARE THE EXCLUSIVE PROPERTY OF BANJO CORPORATION.

BANJO CORPORATION
 150 BANJO DRIVE, CRAWFORDSVILLE, IN 47933
 WEB SITE: WWW.BANJOCORP.COM
 E-MAIL: SALES1@BANJOCORP.COM

UNLESS SPECIFICALLY NOTED, THIS DRAWING AND ITEMS SHOWN ON THIS DRAWING ARE SUBJECT TO CHANGE AT ANY TIME.

DESCRIPTION
2" Female Coupler x 90 Deg Male threads

PART NUMBER
200B90