

PART LIST			
ITEM	QTY	PART NUMBER	DESCRIPTION
1	1	200XPOSS	2" SS PUMP SUB-ASSY
2	4	12901	5/16" FLAT WASHER
3	1	12910	DECAL (N/S)
4	1	17033	Z-RAIL (PAIR)
5	4	17034	5/16-18 X 1-1/2" HHCS
6	4	17040	5/16-24 X 1" HHCS
7	1	E5H	5.5 HP HONDA GX160
8	8	V10118	5/16" LOCKWASHER
9	4	V10119	5/16" HEX NUT

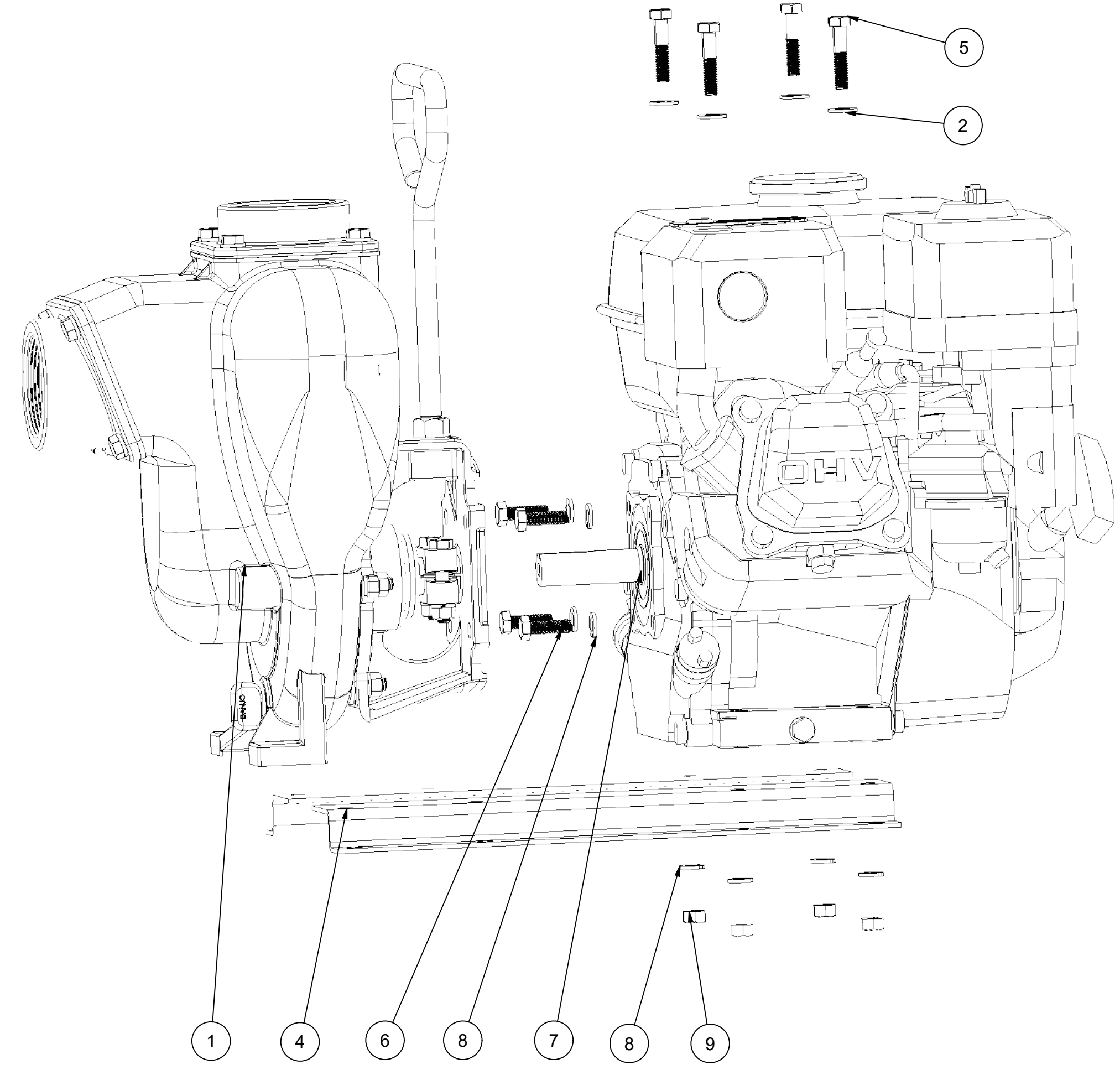

THIS DRAWING AND ALL INFORMATION CONTAINED THEREON ARE THE EXCLUSIVE PROPERTY OF BANJO CORPORATION.

UNLESS SPECIFICALLY NOTED, THIS DRAWING AND ITEMS SHOWN ON THIS DRAWING ARE SUBJECT TO CHANGE AT ANY TIME.

BANJO CORPORATION  
 150 BANJO DRIVE, CRAWFORDSVILLE, IN 47933  
 WEB SITE: WWW.BANJO.CORP.COM  
 E-MAIL: BANJOSALES@IDEXCORP.COM

DESCRIPTION  
**2" STAINLESS PUMP 5H.P. HONDA**

PART NUMBER  
**200PH5-SS**