

Parts List			
ITEM	QTY	PART NUMBER	DESCRIPTION
1	1	150(200)D	CAM LEVER COUPLING DECAL
2	2	150(200)KS	SHORT CAM ARM W/ RING
3	1	200G	2" Coupling Gasket
4	2	200P	CAM ARM PIN
5	1	200XCAP	2" MOLDED CAP

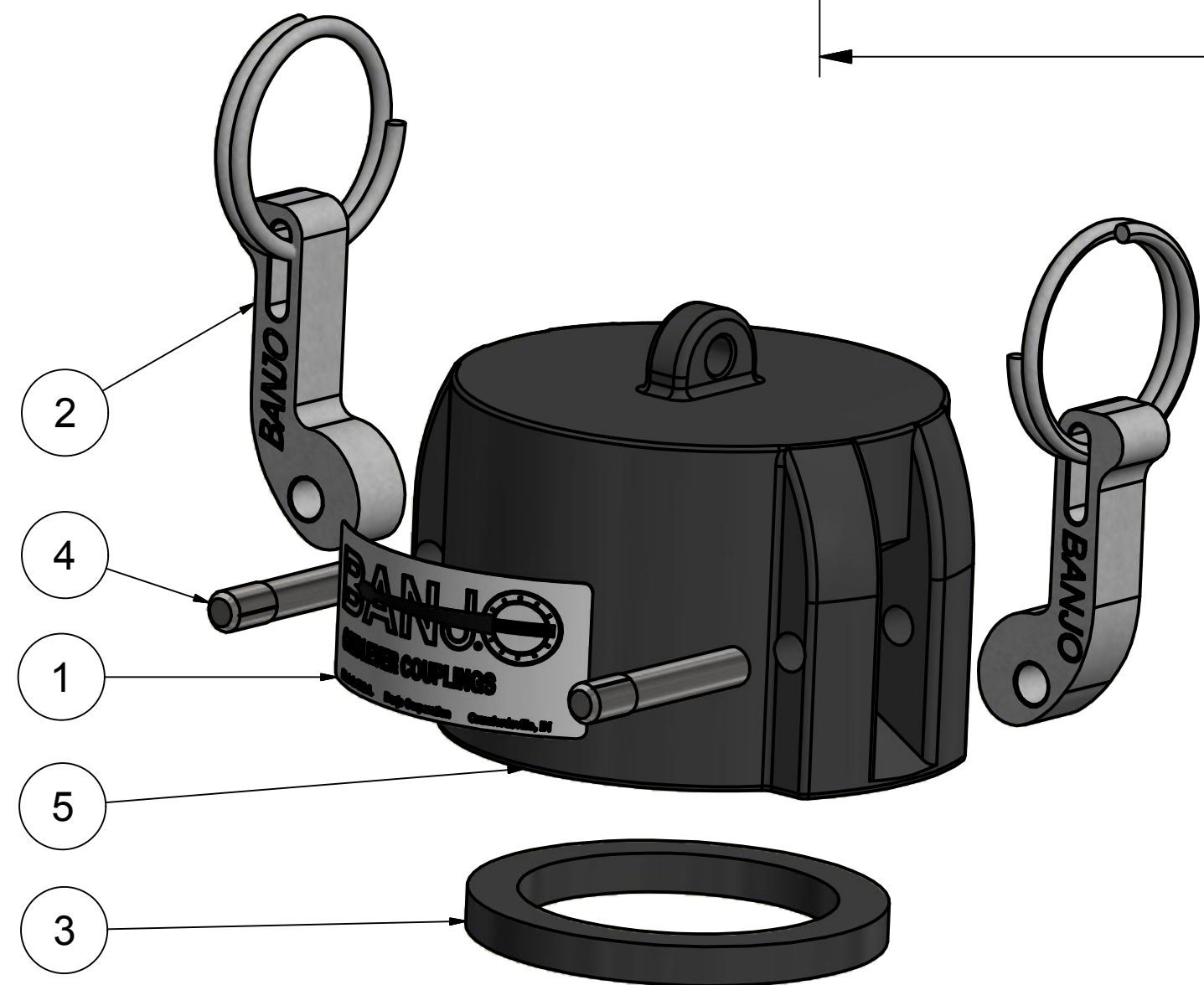
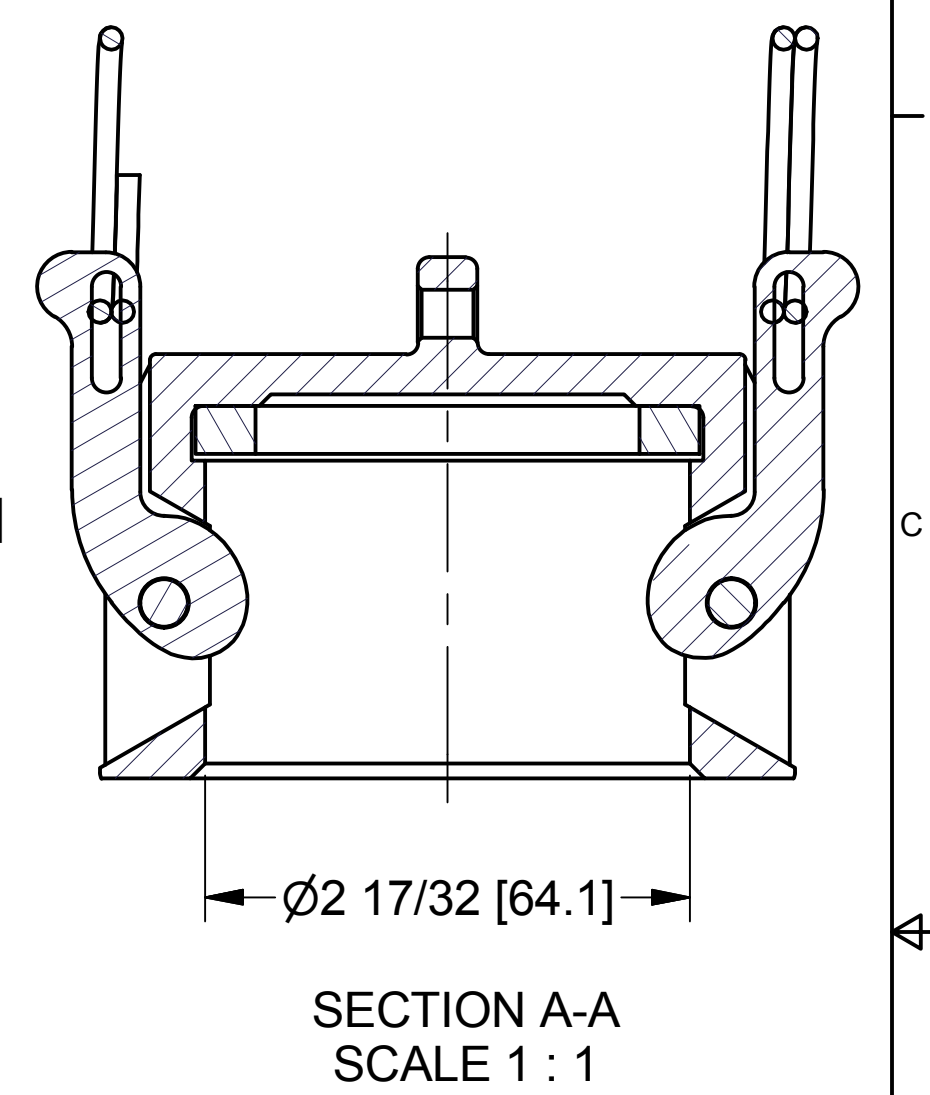
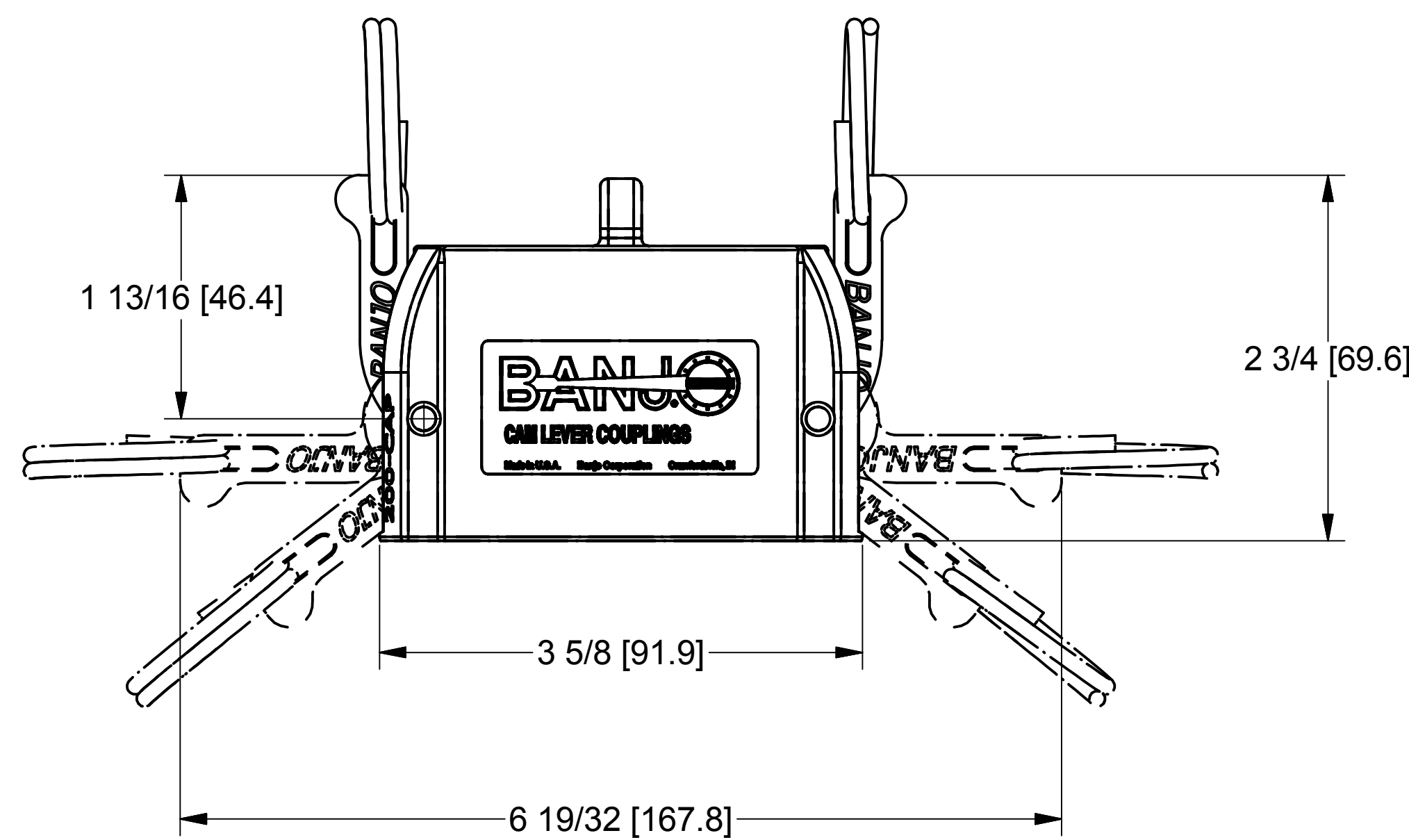
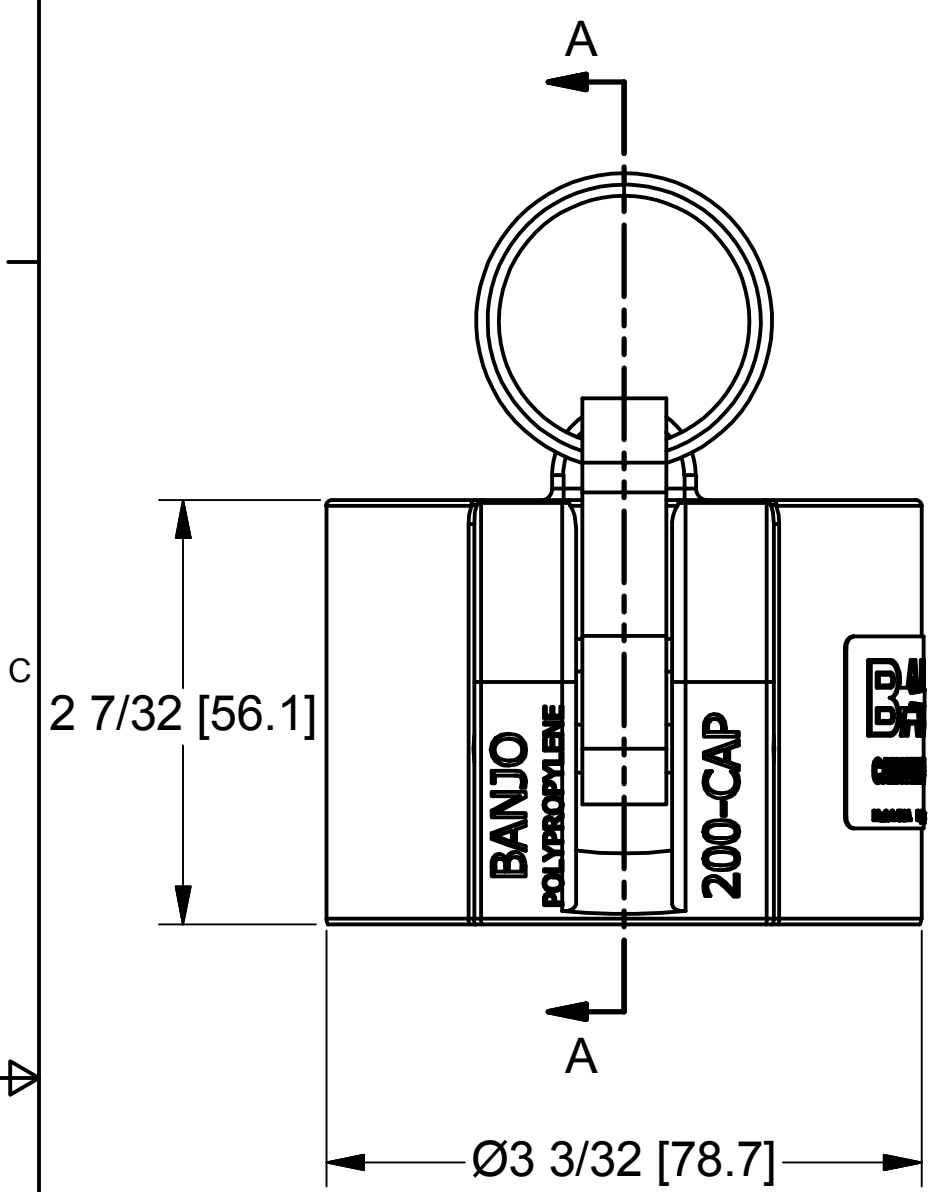

BANJO CORPORATION
 150 BANJO DRIVE, CRAWFORDSVILLE, IN 47933
 WEB SITE: WWW.BANJOCORP.COM
 E-MAIL: SALES1@BANJOCORP.COM

THIS DRAWING AND ALL INFORMATION CONTAINED THEREON ARE THE EXCLUSIVE PROPERTY OF BANJO CORPORATION.

UNLESS SPECIFICALLY NOTED, THIS DRAWING AND ITEMS SHOWN ON THIS DRAWING ARE SUBJECT TO CHANGE AT ANY TIME.

DESCRIPTION
 2" Cap w/ Short Cam Arms
 PART NUMBER
 201CAPSH