

Parts List			
ITEM	QTY	PART NUMBER	DESCRIPTION
1	1	12777	1/2" DRAIN PLUG
2	1	12882A	BEARING PEDESTAL
3	1	15022	2" PUMP HANDLE
4	1	17010	1/2-13 HEX NUT
5	2	17018	PUMP ADAPTER GASKET
6	1	17123	CI PUMP KEYED CLAMP
7	1	17200AP	2" CI WET SEAL ASSY, NEW
8	1	17226	2" WET SEAL PUMP HOUSING SUB-ASSY
9	1	UV15163	#114 O'RING, EPDM
10	6	V10118	5/16" LOCKWASHER
11	6	V10119	5/16" HEX NUT
12	1	12910	DECAL (N/S)
13	1	KK-57	WET SEAL WARNING TAG (N/S)

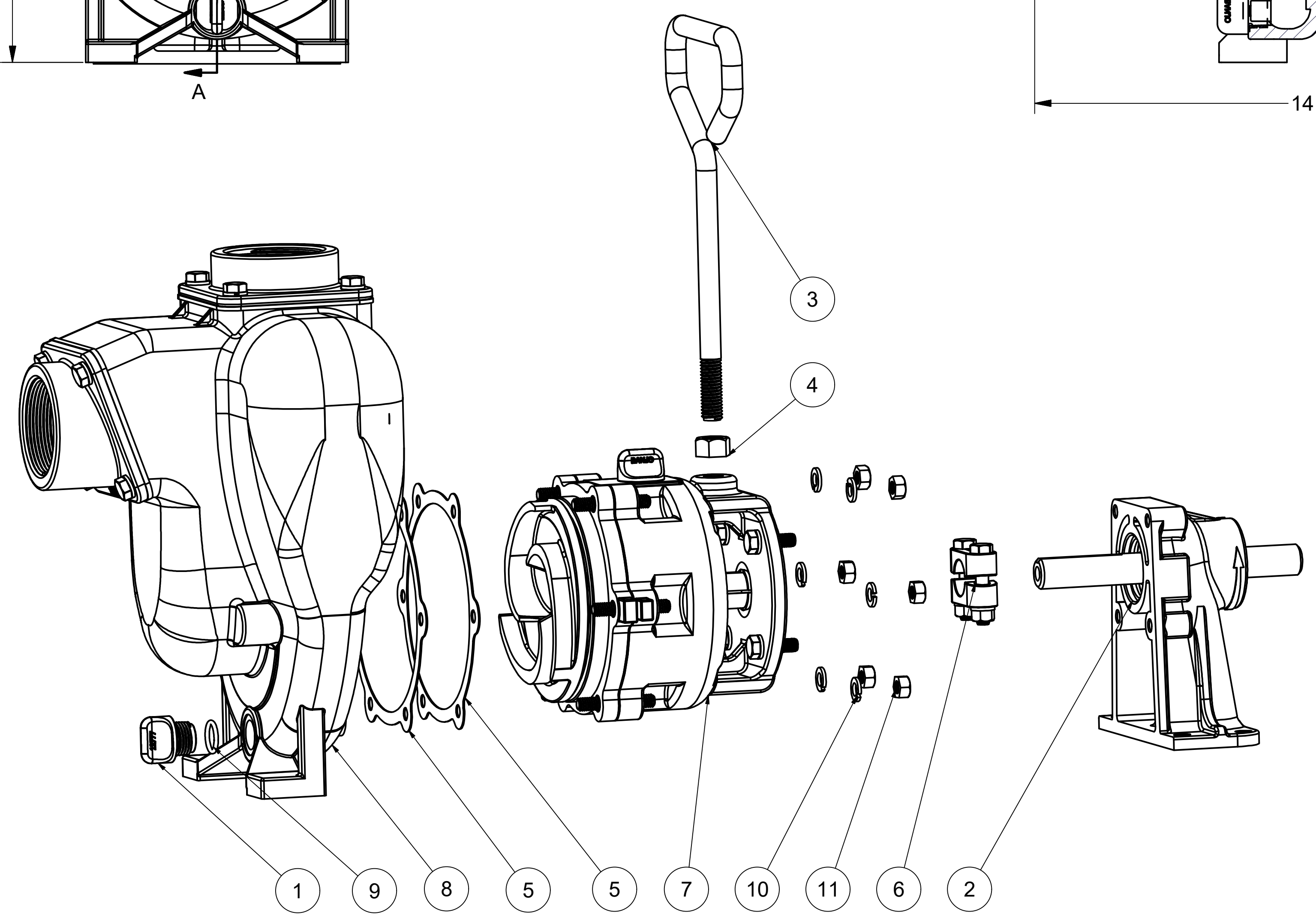

THIS DRAWING AND ALL INFORMATION CONTAINED THEREON ARE THE EXCLUSIVE PROPERTY OF BANJO CORPORATION.

UNLESS SPECIFICALLY NOTED, THIS DRAWING AND ITEMS SHOWN ON THIS DRAWING ARE SUBJECT TO CHANGE AT ANY TIME.

**BANJO CORPORATION**  
 150 BANJO DRIVE, CRAWFORDSVILLE, IN 47933  
 WEB SITE: WWW.BANJOCORP.COM  
 E-MAIL: SALES1@BANJOCORP.COM

DESCRIPTION  
**2" CI WET SEAL PUMP W/ BEARING PED., NEW STYLE**

PART NUMBER  
**201PBIW**