

SECTION B-B
SCALE 1 : 3

PARTS LIST			
ITEM	QTY	PART NUMBER	DESCRIPTION
1	1	12046	56C ADPTR F/ POLY PUMPS-UNASSM
2	1	12702A	2" POLY PUMP VOLUTE
3	1	12703A	POLY PUMP REAR BRACKET
4	1	12705V	PUMP CHECKVALVE, FKM
5	1	12712AVP	2" POLY PUMP BODY- FKM
6	4	12717V	AS568A -011 O-RING, FKM, BROWN
7	1	12719AV	AS568A -375 O-RING, FKM, BROWN
8	10	12720	1/4-20 X 2 1/2" SL IND HWHS
9	2	12725	#6 X 1/2" PPH SMS
10	1	12733V	MECH SEAL ASSY - FKM
11	1	12754V	O'RING SEGMENT
12	1	12765A	5/16-24 X 1 1/8" HFS
13	1	12772	POLY 5 VANE IMPELLER
14	1	12775A	7/16-14 HEX NUT
15	1	12900	#10 X 1 1/2" PPH SMS
16	4	12901	5/16" FLAT WASHER
17	1	12902A	3/16" SQ. X 5/8" KEY
18	4	17029	5/16-18 X 1.75" HHCS
19	1	17701	BASE PLATE
20	8	17704	3/8-16 X 1 1/4" HHCS
21	1	A204V	AS568A -204 O-RING, FKM, BROWN
22	1	BEM5-182CZ	5 HP MOTOR
23	10	V07018	1/4" LOCKWASHER
24	10	V07019	1/4-20 HEX NUT
25	8	V20018	3/8" LOCKWASHER
26	1	12910	PUMP DECAL (N/S)

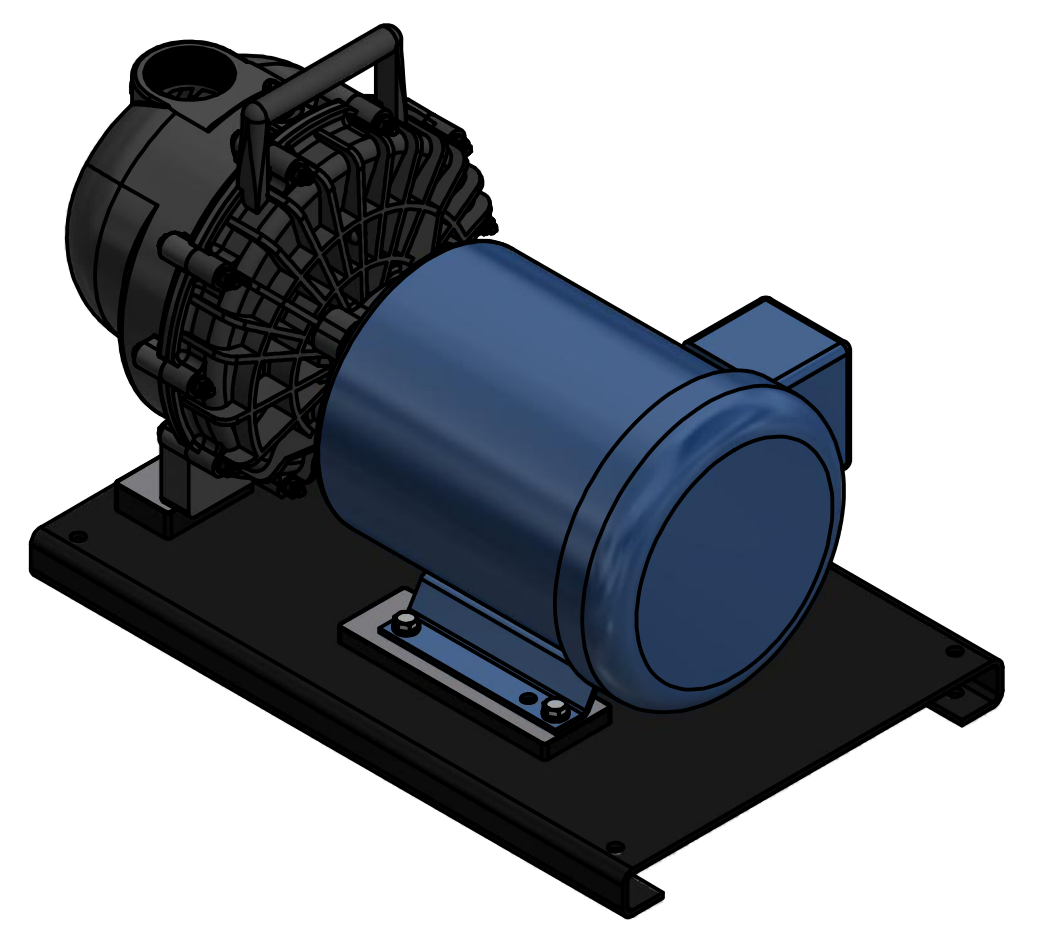
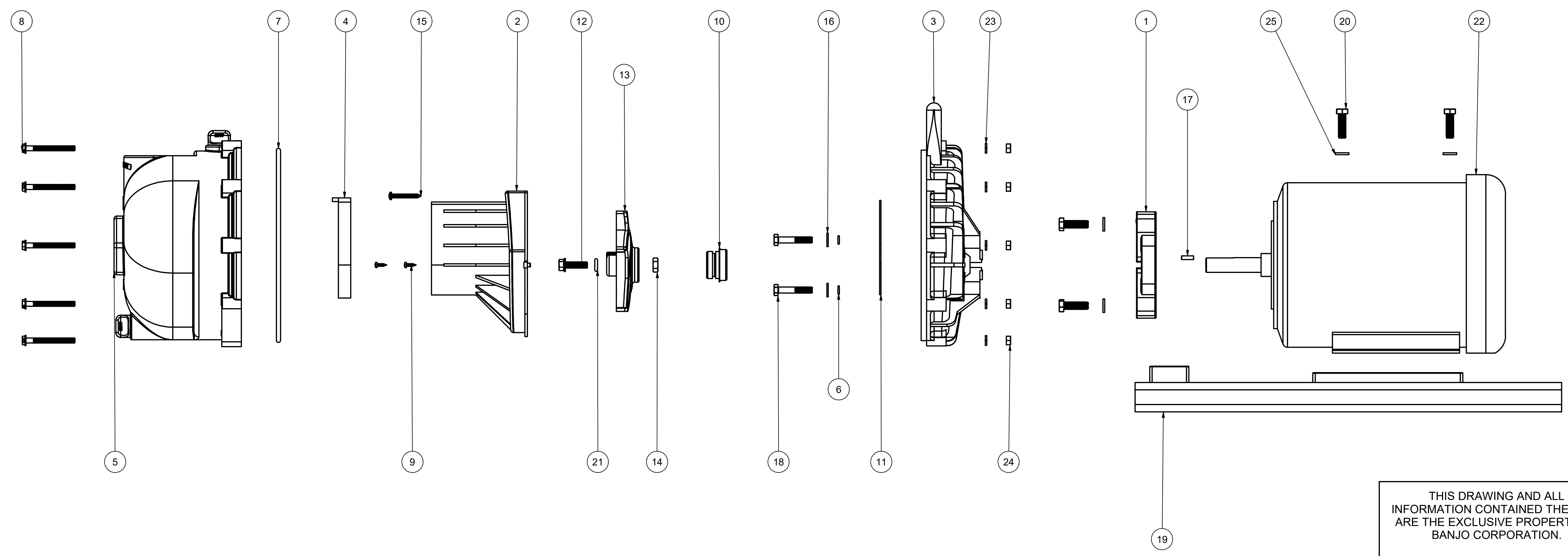

THIS DRAWING AND ALL INFORMATION CONTAINED THEREON ARE THE EXCLUSIVE PROPERTY OF BANJO CORPORATION.
UNLESS SPECIFICALLY NOTED, THIS DRAWING AND ITEMS SHOWN ON THIS DRAWING ARE SUBJECT TO CHANGE AT ANY TIME.

BANJO CORPORATION
150 BANJO DRIVE, CRAWFORDSVILLE, IN 47933
WEB SITE: WWW.BANJO.CORP.COM
E-MAIL: BANJOSALES@DEXCORP.COM

DESCRIPTION
2" PUMP WITH 5HP CC MOTOR - FKM

PART NUMBER
234PPE5V