

Parts List			
ITEM	QTY	PART NUMBER	DESCRIPTION
2	1	300G	3" COUPLING GASKET, EPDM
3	2	300K	CAM ARM
4	2	300P	CAM ARM PIN
5	1	300XD	3" D COUPLING, MOLDED

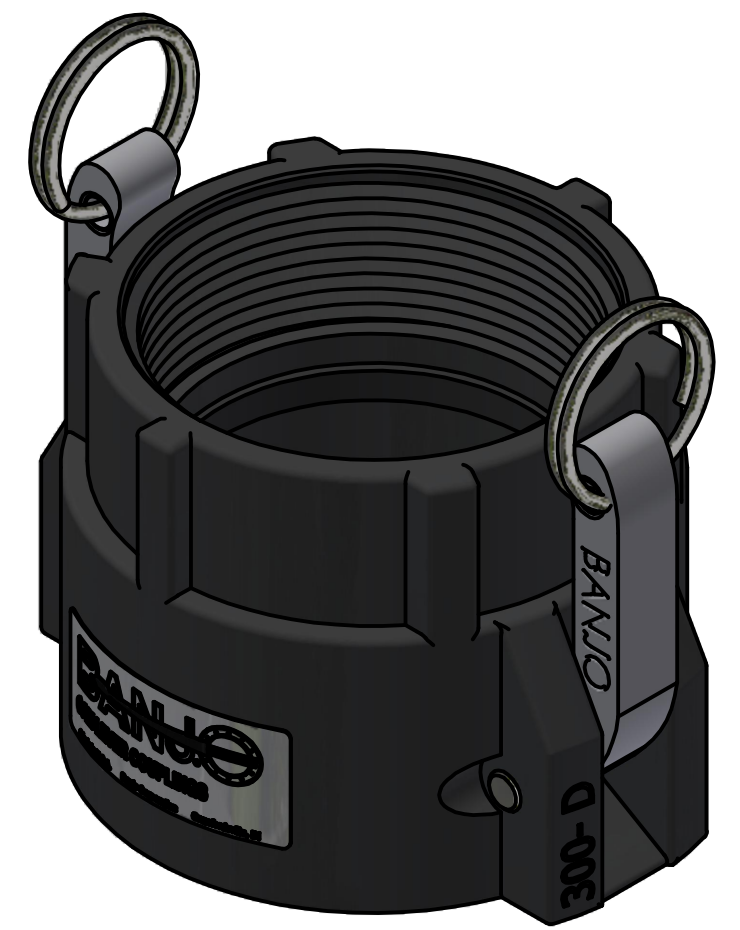
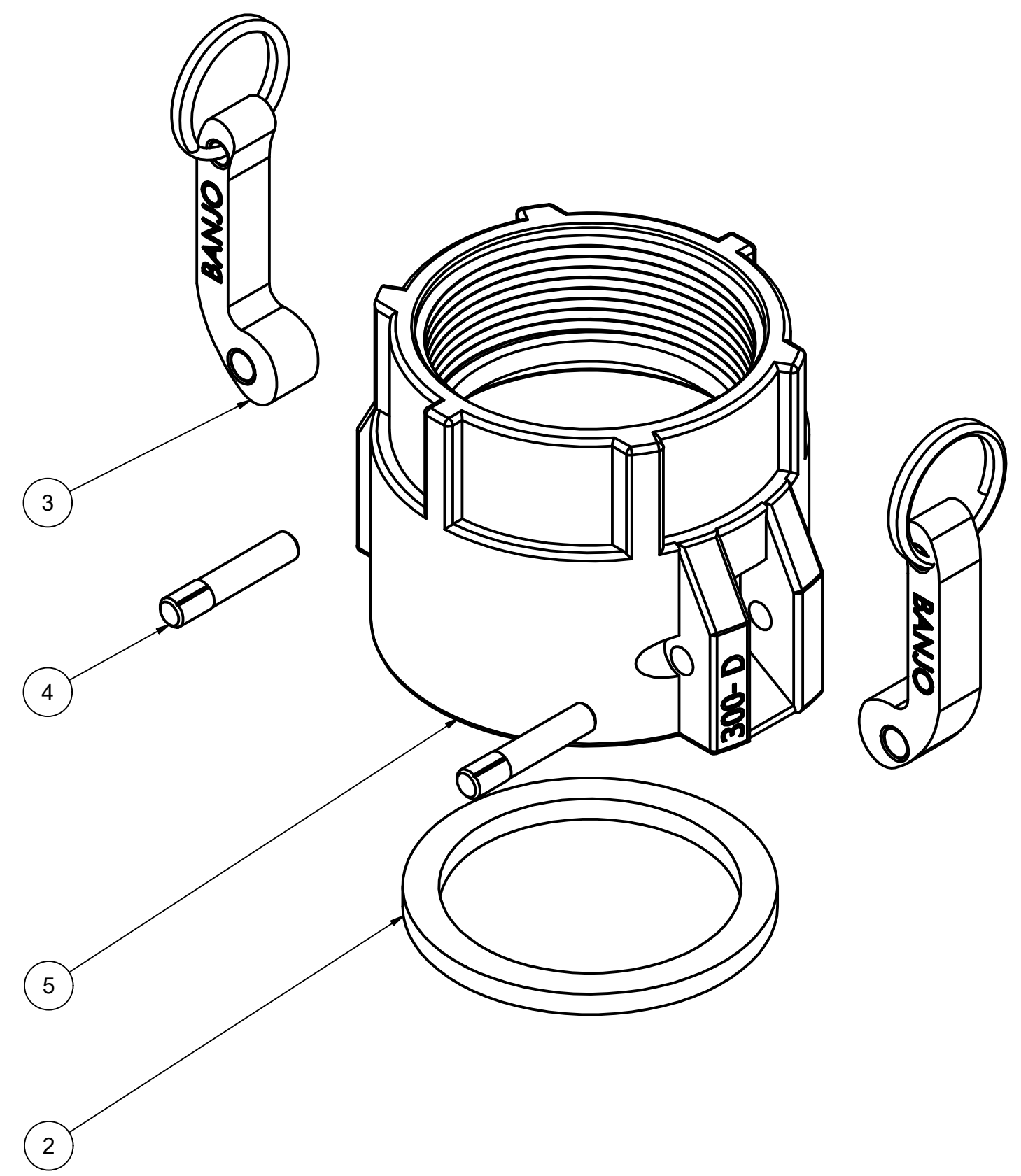
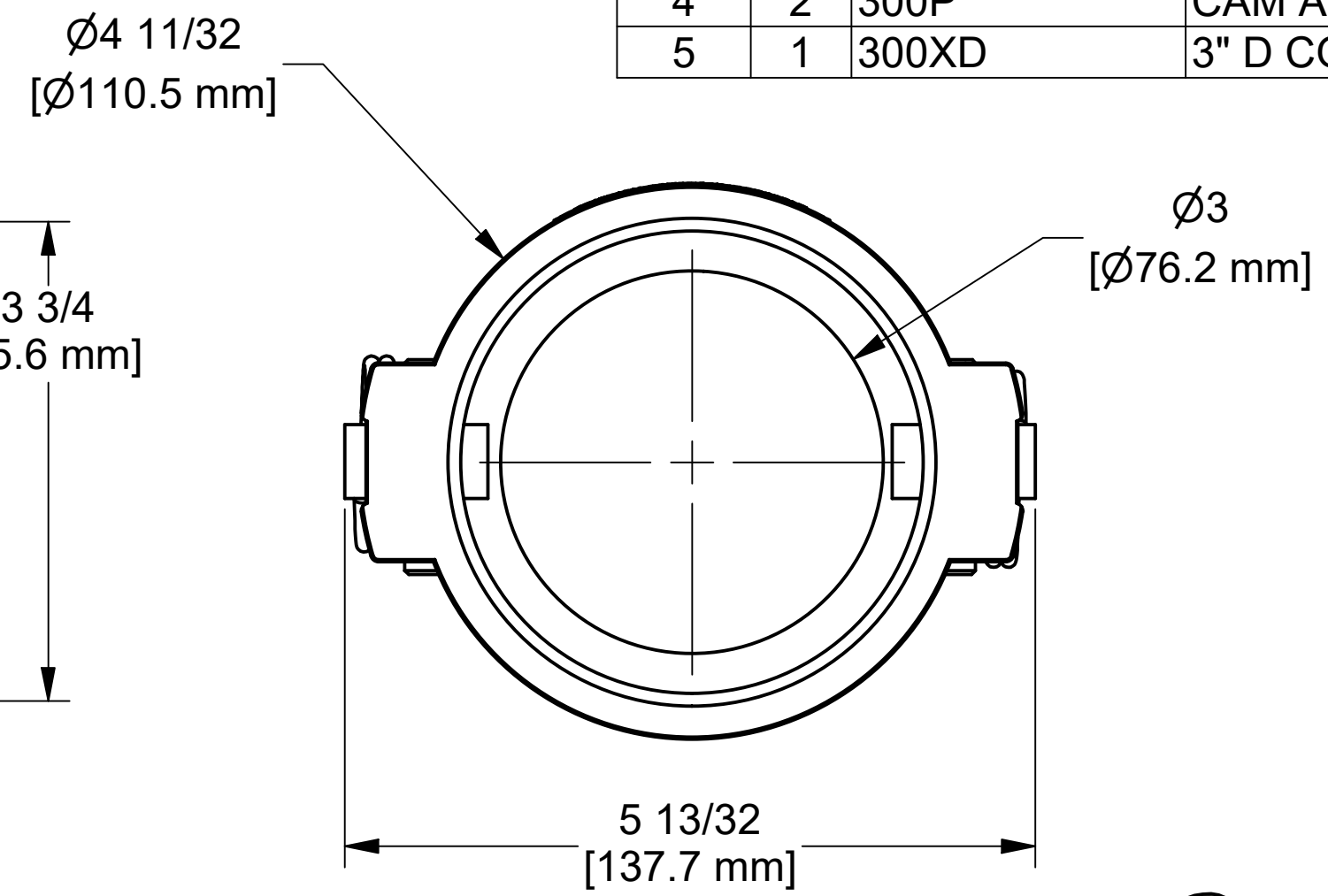
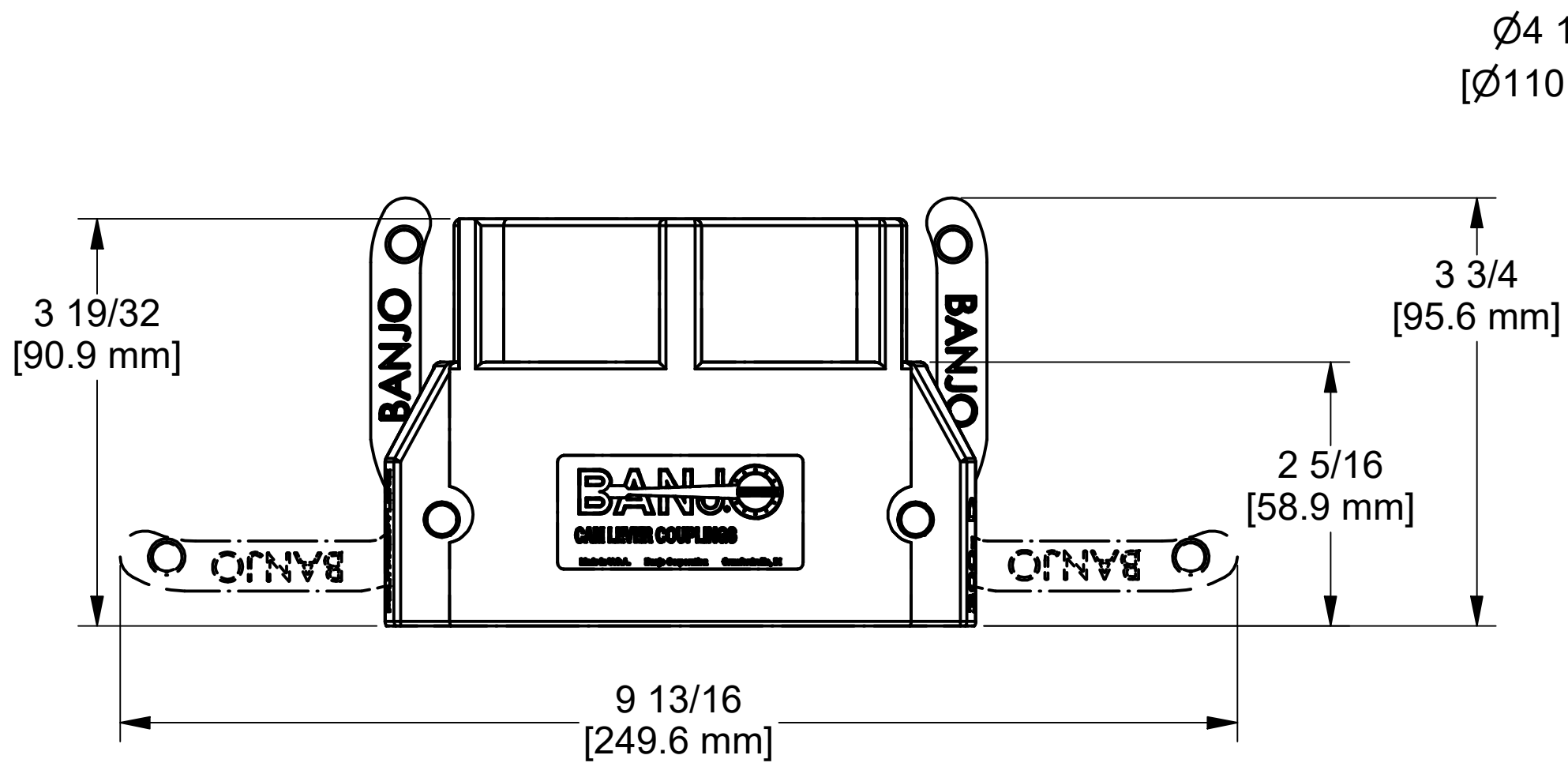

THIS DRAWING AND ALL INFORMATION CONTAINED THEREON ARE THE EXCLUSIVE PROPERTY OF BANJO CORPORATION.

UNLESS SPECIFICALLY NOTED, THIS DRAWING AND ITEMS SHOWN ON THIS DRAWING ARE SUBJECT TO CHANGE AT ANY TIME.

BANJO CORPORATION  
150 BANJO DRIVE, CRAWFORDSVILLE, IN 47933  
WEB SITE: WWW.BANJOCORP.COM  
E-MAIL: BANJOSALES@IDEXCORP.COM

DESCRIPTION  
**3" FEMALE COUPLING x 3" FEMALE THREAD**

PART NUMBER  
**300D**