

PARTS LIST			
ITEM	QTY	PART NUMBER	DESCRIPTION
2	1	300G	3" COUPLING GASKET, EPDM
3	2	300K	CAM ARM
4	2	300P	CAM ARM PIN
5	1	300XDB	300-D UNASSEMBLED BSP

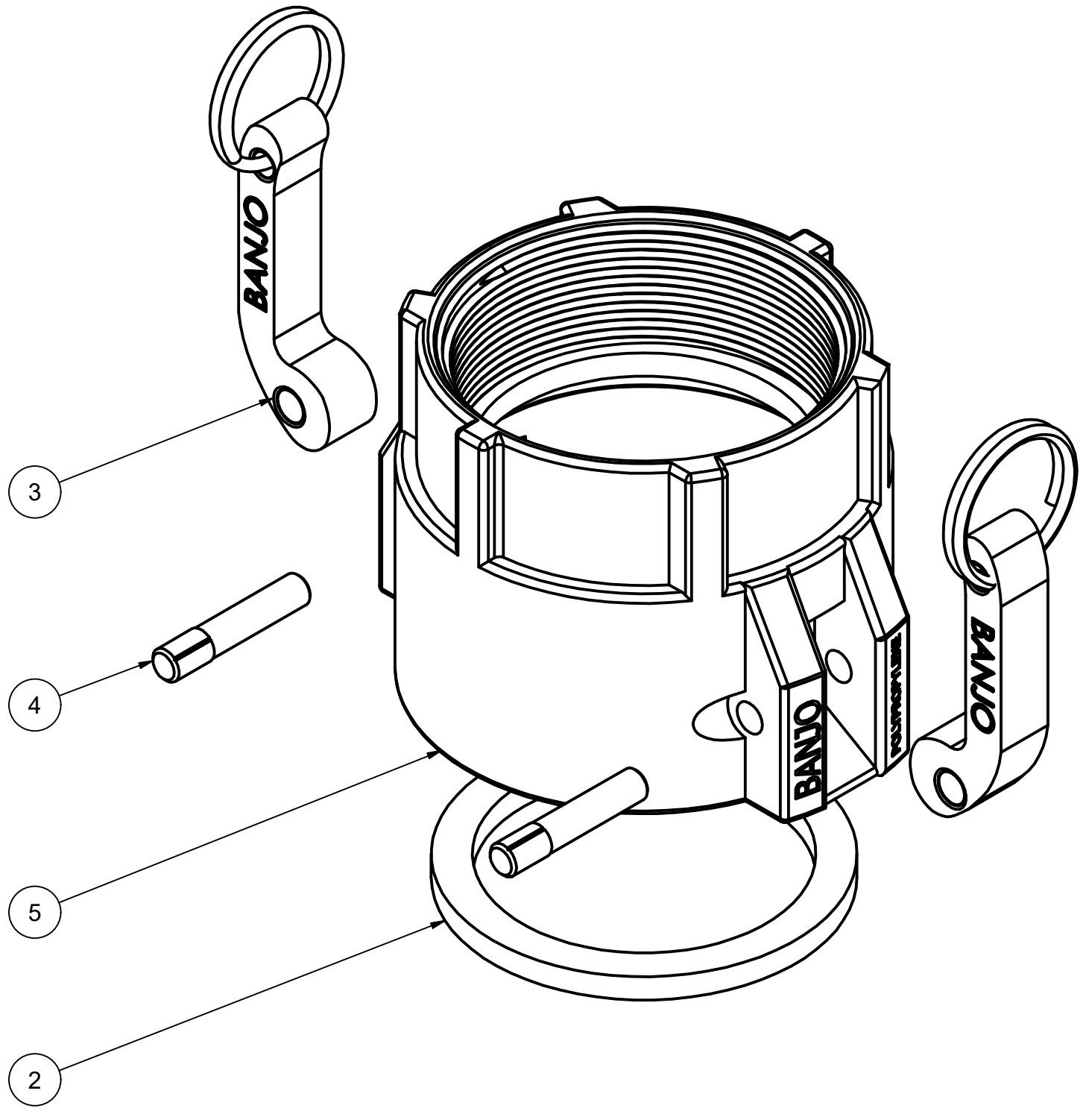
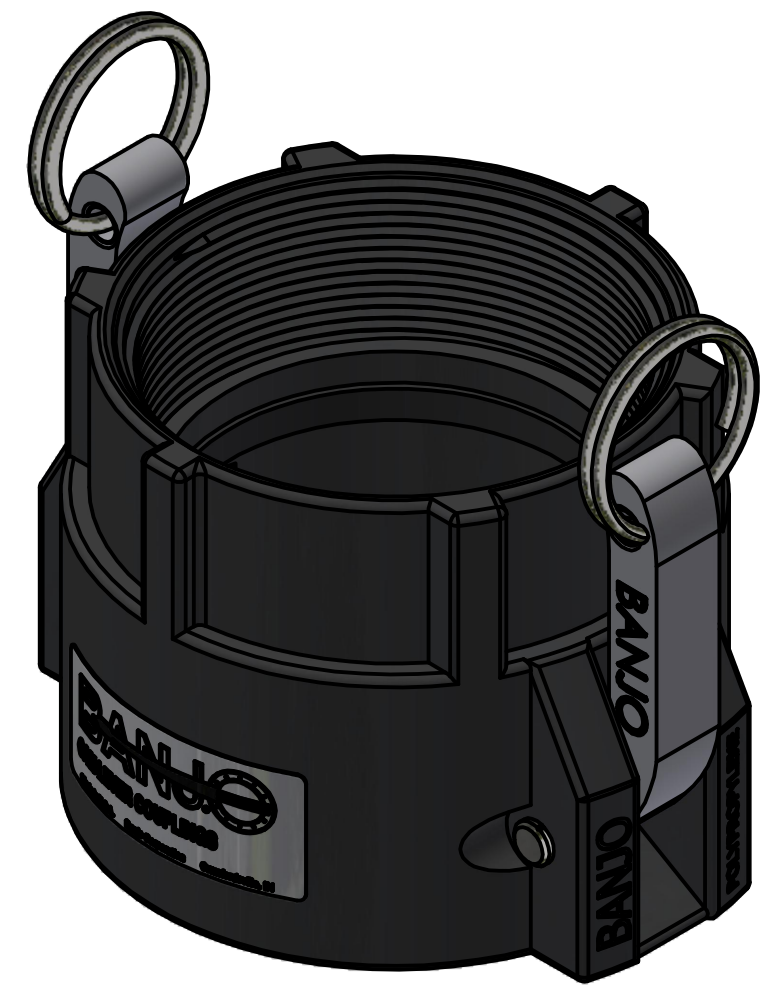
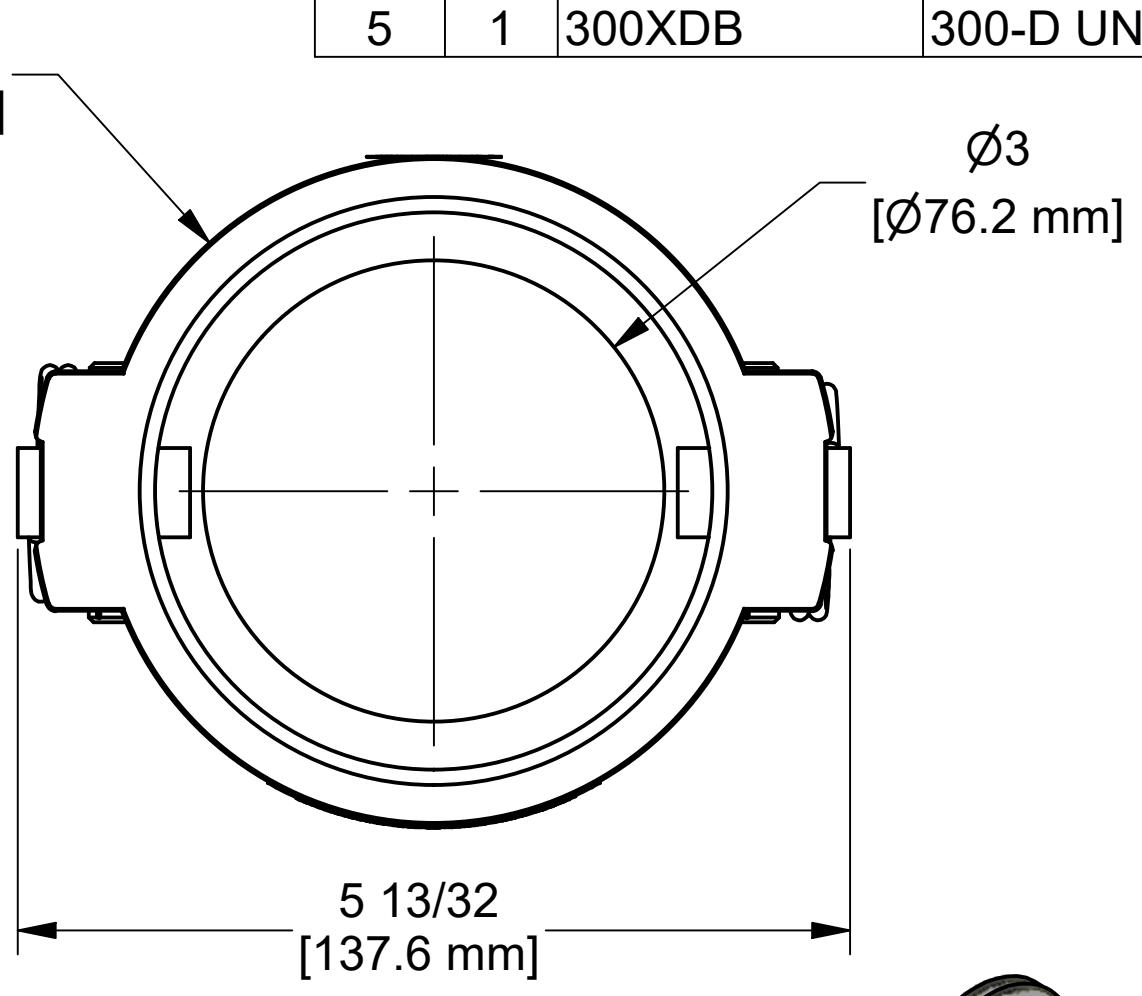
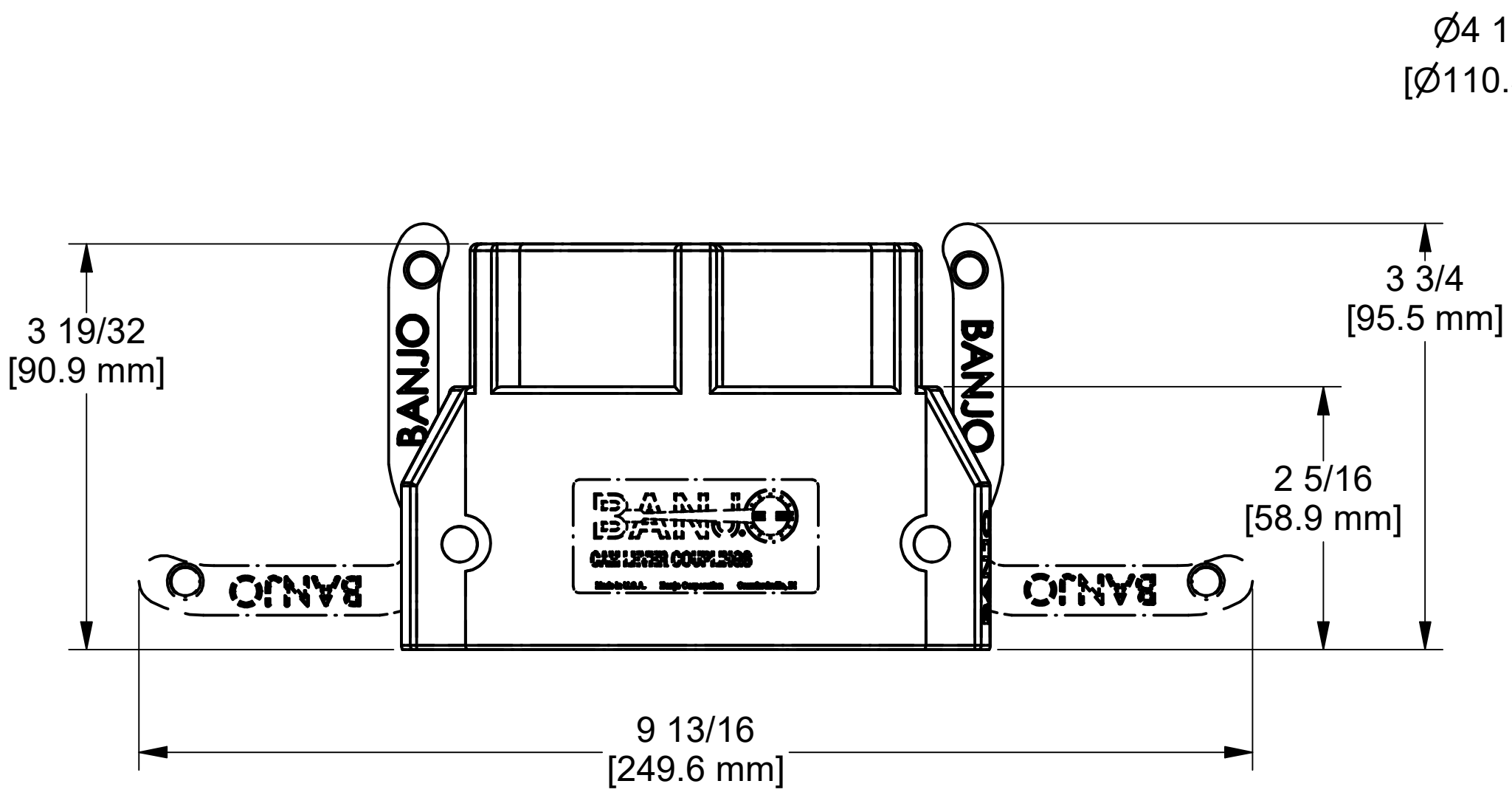

THIS DRAWING AND ALL INFORMATION CONTAINED THEREON ARE THE EXCLUSIVE PROPERTY OF BANJO CORPORATION.

UNLESS SPECIFICALLY NOTED, THIS DRAWING AND ITEMS SHOWN ON THIS DRAWING ARE SUBJECT TO CHANGE AT ANY TIME.

BANJO CORPORATION
 150 BANJO DRIVE, CRAWFORDSVILLE, IN 47933
 WEB SITE: WWW.BANJOCORP.COM
 E-MAIL: BANJOSALES@IDEXCORP.COM

DESCRIPTION
3" FEMALE COUPLING x 3" FPT BSP

PART NUMBER
300DB