



3" Cast Iron & Stainless Steel Pump Instruction Manual

300PI8PRO, 300PIH-8,
300PIH-11, 300PIH13

Read these instructions and the instructions covering the operation of the engine before starting the engine. Do not operate the engine until you have put oil in the engine crankcase. It is wise to check the oil level each time the gasoline tank is filled. If the pump is used only occasionally, check oil and gasoline before starting engine.

Do not run the pump dry. Always fill the pump body with water (or liquid to be pumped) before starting pump. It is not necessary to drain the pump body after use, unless there is a danger of freezing.

Use a regular grade of gasoline (unleaded and uncolored if available). Remove the engine cylinder head after 100 hours of operation and remove the carbon and lead deposits from the combustion chamber and top of the piston.

Make certain that all hose and pipe connections are air-tight. An air leak in the suction line may prevent priming and will reduce the capacity of the pump.

Always place the pump as close to the liquid to be pumped as possible. Keep the suction line short and with few bends. Keep the pump and engine on a level foundation. A poor foundation and a heavy suction hose (made heavier when "primed" full of liquid) could result in a pump "down the hole".

There are important instructions regarding preparing the engine for long periods of idleness. (Read the engine instruction manual). Under these conditions, drain the pump completely, turn the engine over a few times and leave all plugs (filter and drain) out of the pump. Always try to store the unit in a heated and dry building.

When pumping dirty water or other liquids containing solids, always use a pump strainer on the end of the suction line. There are no points on the pump which need lubrication. The shaft seal is self-lubricating, and designed to handle clean or dirty liquids.

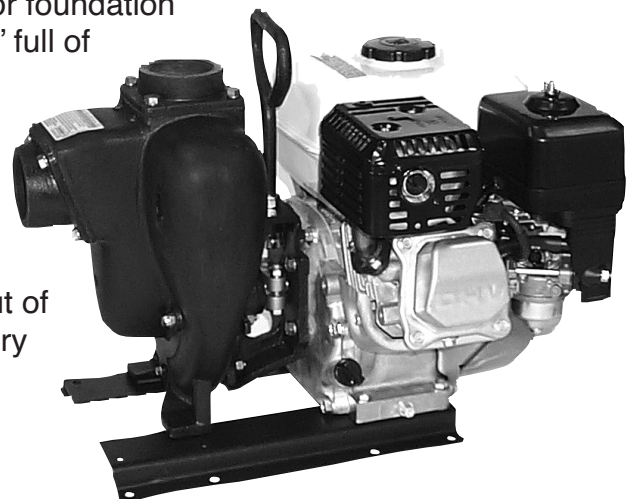
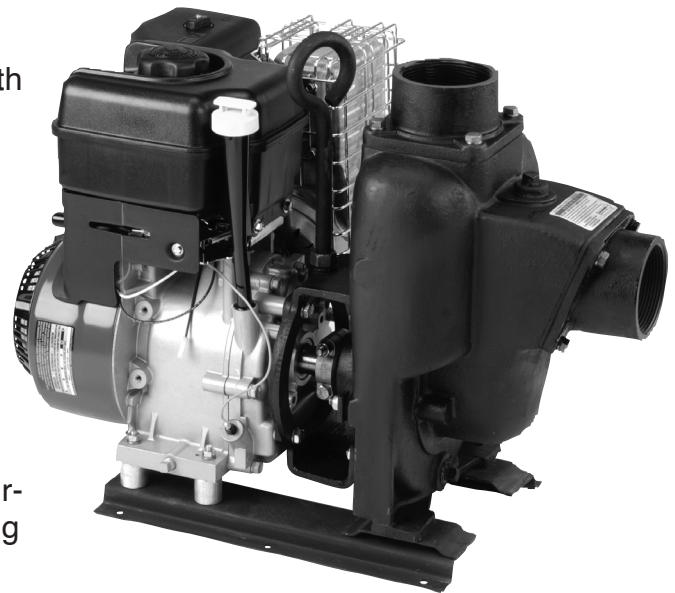

DISASSEMBLY INSTRUCTIONS:

1. Remove bolted clamp from shaft. Remove (4) bolts holding motor or Bearing Pedestal to the adapter plate.



2. Remove (6) nuts and lock washers holding adapter plate to housing. Using a screwdriver behind the side tabs, gently pry the adapter loose. Remove impeller, drive sleeve and seal assembly.

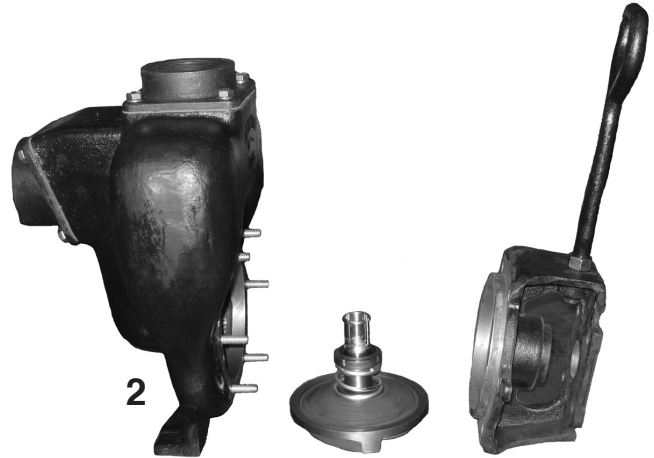

3. Remove two stainless steel flat head screws and remove wear plate. Replace the wear plate when there are surface grooves or excessive wear.

When reassembling, make sure there is no foreign material between the wear plate and the pump housing that would prevent the wear plate from lying flat.

4. Remove the seal and spring from the impeller and drive sleeve. Inspect the surface of the impeller sleeve. The surface can be cleaned with very fine sandpaper (#400) or if excessively worn or grooved, the impeller should be replaced. Remember, a worn impeller can cause an out of balance condition resulting in vibration and seal wear.

Always install a new seal assembly onto impeller before reassembling pump. It is very important not to scratch or mark the black carbon surface of the seal assembly.

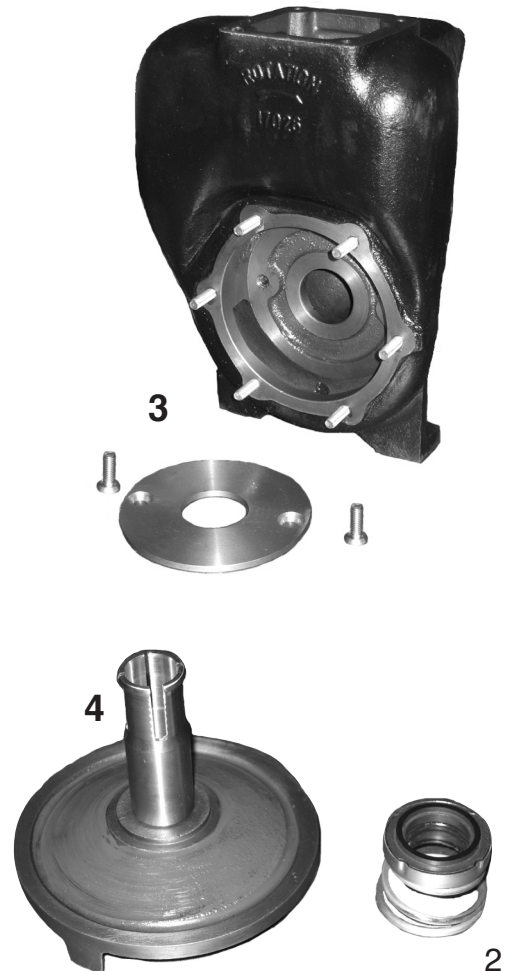

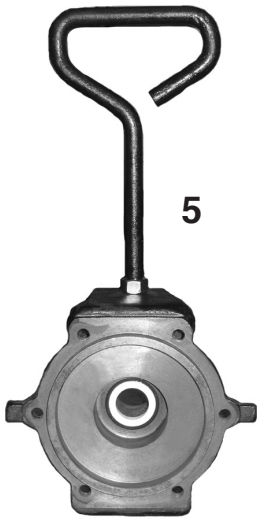

5. Remove the white ceramic seal and rubber cup from the rear adapter. Clean the recess opening with sandpaper or wire brush.

Install the new seal half.

Very important to not scratch or mark the white ceramic seal surface. It is usually helpful to apply a small amount of lubrication to the rubber cap and then press the seal into position, using your two thumbs or arbor press to press in evenly. Make sure the seal is in position straight and true to prevent seal wobble.



6. A shim is used to set the clearance between the impeller and wear plate. Any shim with a thickness of .030/.040 can be used. An ideal shim is a 1/2" wide piece of No. 21 gauge sheet metal.

Place the impeller and seal half assembly in position with impeller face against the banding material.



7. Install rear adapter using a new adapter gasket. Tighten (6) nuts.

8. Install pump to gas engine or bearing pedestal and tighten bolts.

Install bolted clamp and tighten bolts. The clamp bolts should be very tight. They should also be tightened equally so the space from side to side between clamps is equal for balance and to prevent vibration.

After all bolts are tight, grip the banding material and pull out.

After shim is removed the pump should turn freely.

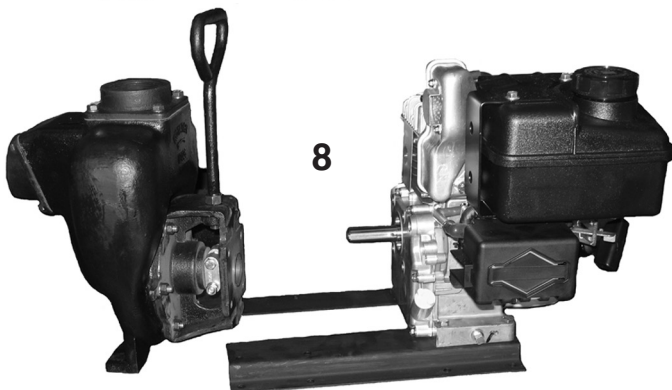

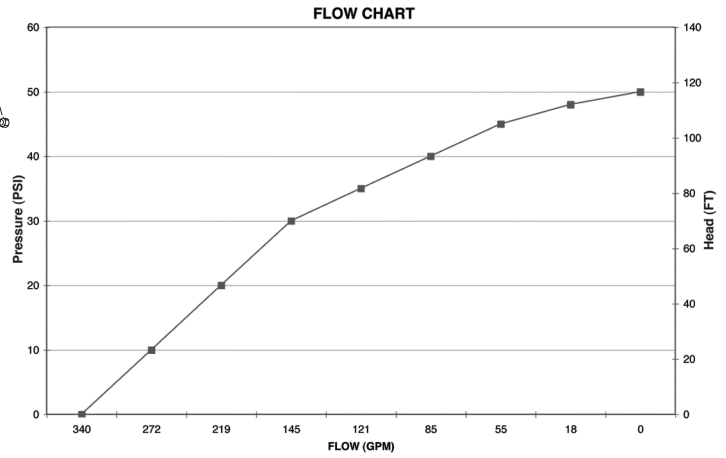
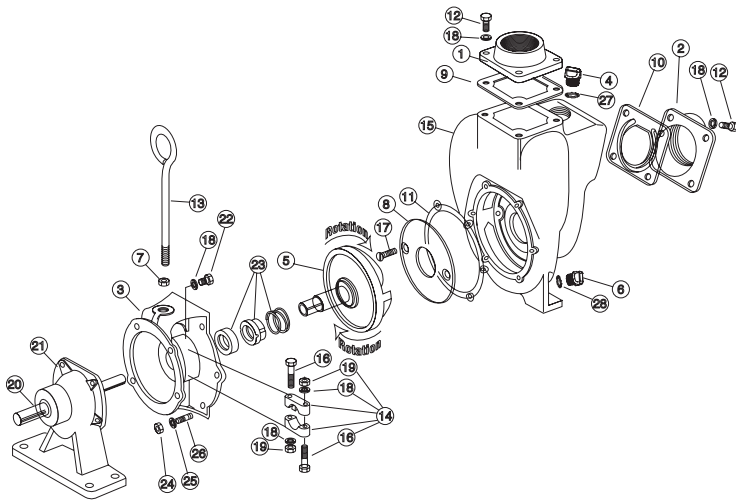

REPLACEMENT PARTS 3" SS PUMPS			
ITEM	PART NO	DESCRIPTION	QTY
1	18008SS	NPT Outlet Flange	1
2	18012SS	NPT Inlet Flange	1
3	18026SS	Adapter for Gas Engine	1
3	18048SS	SS C-Flange Adapter	1
4	13777SS	3/4" Stainless Steel Plug	1
5	18023SS	1" SS Impeller & Drive Shaft for Gas Engine	1
5	18023-1.125SS	1 1/8" SS Impeller & Drive Shaft for Electric Motor	1
6	12777SS	1/2" Stainless Steel Plug	1
7	18034	5/8" SS Jam Nut	1
8	18004SS	SS Wear Plate	1
9	18044	FKM (viton type) Outlet Gasket	1
10	18042	FKM (viton type) Gasket Check Valve Assembly	1
11	18021	Adapter Gasket	1
12	18010SS	3/8" - 16 x 1 1/8" SS Cap Screw HXHD	8
13	18033	Handle	1
14	18129	Clamp Assembly	1
15	18001SS	SS Pump Housing	1
16	18030	3/8" -24 x 2 1/4" SS Bolt	2
17	18106SS	Wear Plate Flat Head Screw	2
18	V20018	3/8" Lock Washer	8
19	18032	3/8" x 24 SS Hex Nut	2
20	18504	1" Shaft	1
21	18500	Bearing Pedestal	1
22	18027	3/8" -16 x 1 1/2" HHCS	1
23	18025SS	FKM (viton type) Seal Assembly	1
24	V20019	3/8" 16 SS Hex Nut	6
25	V20018	3/8" SS Lock Washer	6
26	18218	3/8" -16 x 24 x 2 1/8" SS Stud	6
27	13778V	O-Ring FKM (viton type)	1
28	UV15163V	O-Ring FKM (viton type)	1
N/S	18100SS	Repair Kit(Consist of items 5, 8,11,17 & 23)	1

REPLACEMENT PARTS 3" CAST IRON PUMPS			
ITEM	PART NO	DESCRIPTION	QTY
1	18008	NPT Outlet Flange	1
1	M18008	3" Manifold Outlet Flange	1
2	18012	NPT Inlet Flange	1
2	M18012	3" Manifold Inlet Flange	1
3	18026	Adapter for Gas Engine & Bearing Pedestal	1
3	18048	C-Flange Adapter	1
3	18049	Hydraulic Motor Adapter	1
N/S	18055	Hydraulic Adapter Shaft	1
4	13777	3/4" Plug	1
5*	18023	1" Impeller & Drive Shaft for Gas Engine	1
5	18023-1.125	1 1/8" Impeller & Drive Shaft for Electric Motor	1
6	12777	1/2" Plug	1
7	18034	5/8" SS Jam Nut	1
8	18004	Wear Plate	1
9	18009	EPDM Outlet Gasket	1
10	18013	Gasket Check Valve Assembly	1
11	18021	Adapter Gasket	1
12	18010SS	3/8" - 16 x 1 1/8" SS Cap Screw HXHD	8
13	18033	Handle	1
14	18029	Clamp Assembly (Old Style)	1
14	18129	Clamp Assembly (New Style)	1
15	18001	Pump Housing	1
16	18030	3/8" -24 x 2 1/4" Bolt	2
17	18106	Wear Plate Flat Head Screw	2
18	V20018	3/8" Lock Washer	8
19	18032	3/8" x 24 SS Hex Nut	2
20	18504	1" Shaft	1
21	18500	Bearing Pedestal	1
N/S	18502	Bearing SKF 66306-2RS1/C3	2
22	17704	Bolt	4
23*	18025	FKM (viton type) Seal Assembly	1
23	18025SD	Severe Duty Seal	1
24	V20019	3/8" 16 SS Hex Nut	6
25	V20018	3/8" SS Lock Washer	6
26	18218	3/8" -16 x 24 x 2 1/8" SS Stud	6
27	13778	O-Ring	1
28	UV15163	O-Ring	1
N/S	18035	Z-Rail Mounting Bracket (Pair)	1
N/S	18100	Repair Kit (Consist of items 5*, 8,11,17, 23*)	1