

Parts List			
ITEM	QTY	PART NUMBER	DESCRIPTION
1	2	BF200GE	2" B.F. GASKET
2	1	BF201A	BOLTED FLANGE PLATE
3	4	BF206	3/8-16 X 2 1/2" HHCS
4	4	BF304A	BOLTED FLANGE PLUG
5	4	V20018	3/8" LOCKWASHER
6	4	V20019	3/8" HEX NUT
7	1	V20157	1 1/2" END PLATE
8	1	VL1004	EPDM DECAL (N/S)

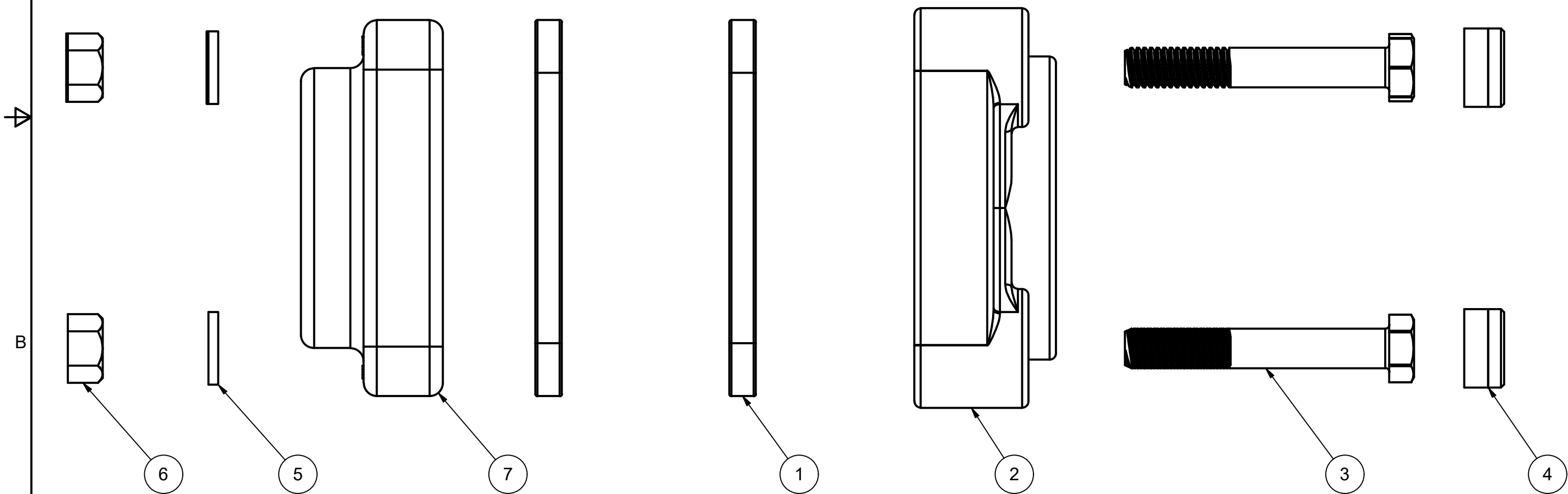
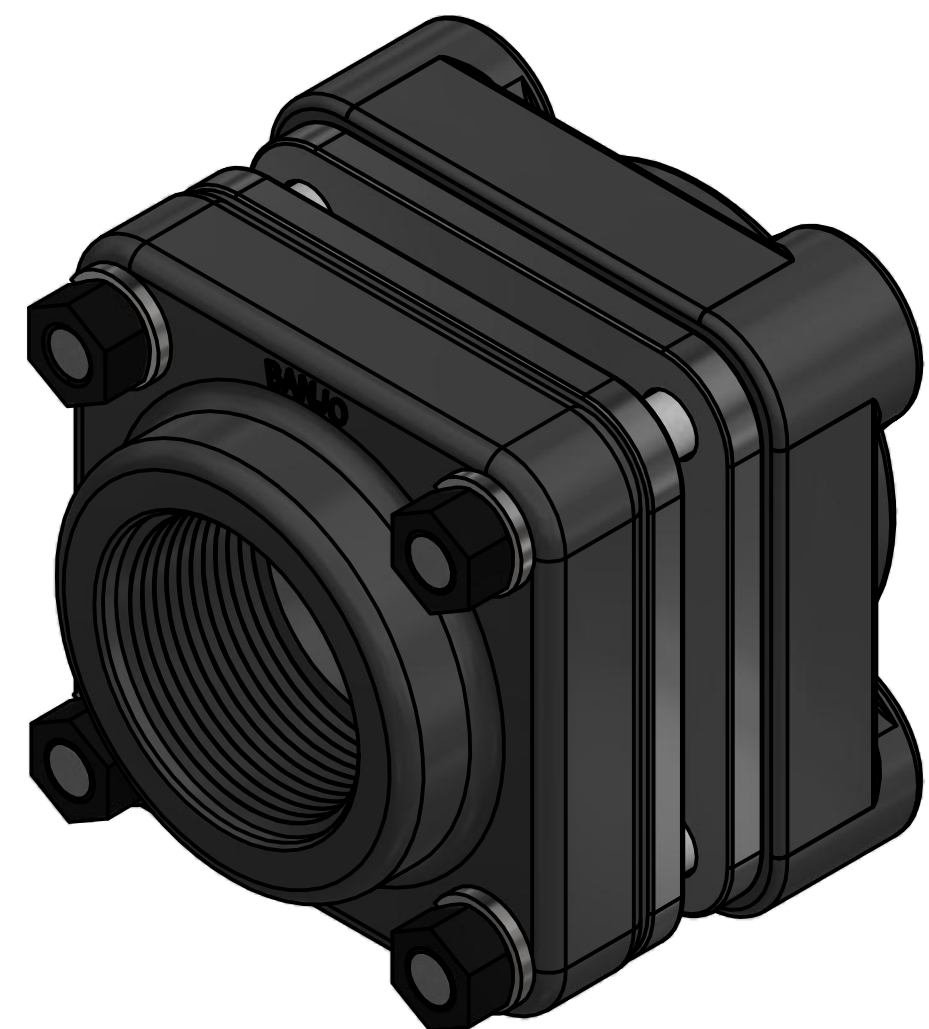

THIS DRAWING AND ALL INFORMATION CONTAINED THEREON ARE THE EXCLUSIVE PROPERTY OF BANJO CORPORATION.

UNLESS SPECIFICALLY NOTED, THIS DRAWING AND ITEMS SHOWN ON THIS DRAWING ARE SUBJECT TO CHANGE AT ANY TIME.

BANJO CORPORATION  
 150 BANJO DRIVE, CRAWFORDSVILLE, IN 47933  
 WEB SITE: WWW.BANJOCORP.COM  
 E-MAIL: BANJOSALES@IDEXCORP.COM

DESCRIPTION  
 1.5" X 2" NPT BOLTED FLANGE, EPDM

PART NUMBER  
 BF150