

SECTION A-A  
SCALE 1 : 1

Parts List			
ITEM	QTY	PART NUMBER	DESCRIPTION
1	4	BF200GFV	BOTTOM DRAIN GASKET
2	1	BF200GV	2" BOLTED FLANGE GASKET
3	1	BF201BD	BOLTED FLANGE PLATE
4	4	BF304A	BOLTED FLANGE PLUG
5	4	BF306	3/8"-16 x 2.75" HHCS
6	4	V20018	3/8" LOCKWASHER
7	4	V20019	3/8" HEX NUT
8	1	V20156	2" FLAT END PLATE
9	1	VL1005	FKM DECAL (N/S)

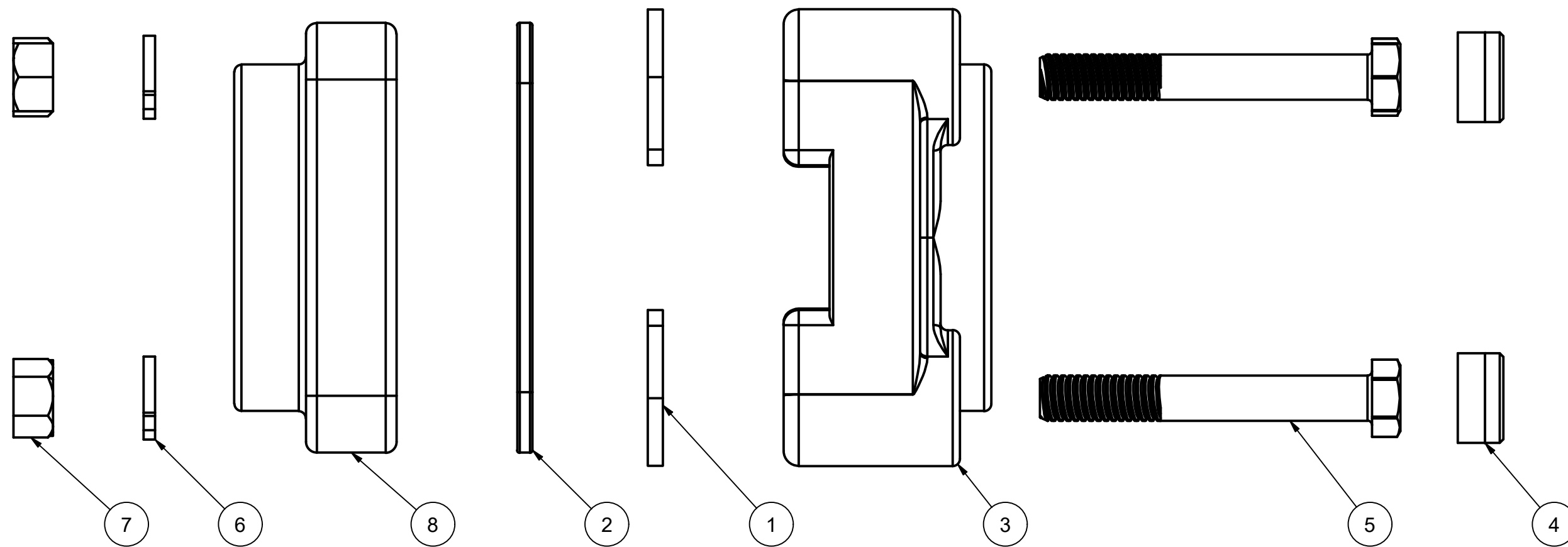
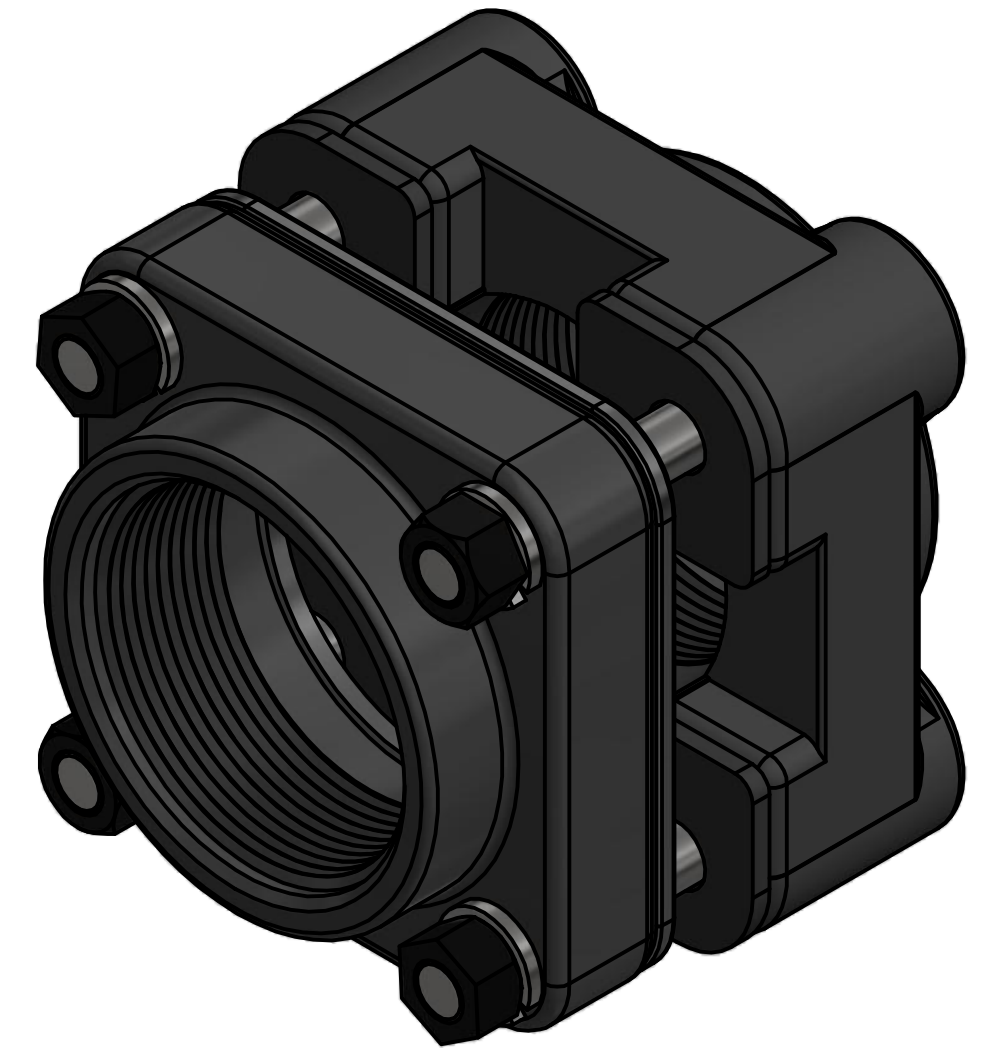

THIS DRAWING AND ALL INFORMATION CONTAINED THEREON ARE THE EXCLUSIVE PROPERTY OF BANJO CORPORATION.

UNLESS SPECIFICALLY NOTED, THIS DRAWING AND ITEMS SHOWN ON THIS DRAWING ARE SUBJECT TO CHANGE AT ANY TIME.

BANJO CORPORATION  
150 BANJO DRIVE, CRAWFORDSVILLE, IN 47933  
WEB SITE: WWW.BANJOCORP.COM  
E-MAIL: BANJOSALES@IDEXCORP.COM

DESCRIPTION  
2" X 2" NPT BOTTOM DRAIN BOLTED FLANGE, FKM

PART NUMBER  
BF200BDV