

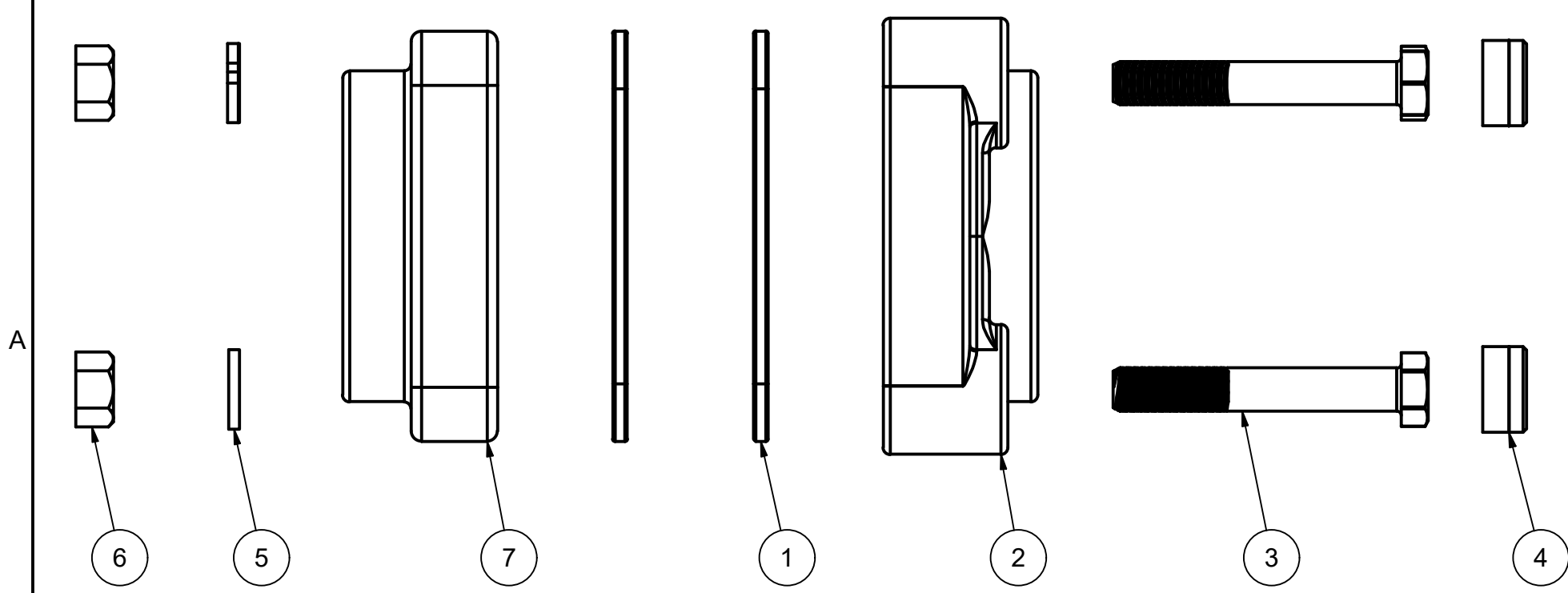

PARTS LIST			
ITEM	QTY	PART NUMBER	DESCRIPTION
1	2	BF200GV	2" BOLTED FLANGE GASKET-FKM
2	1	BF201A	BOLTED FLANGE PLATE
3	4	BF206	3/8-16 X 2 1/2" HHCS
4	4	BF304A	BOLTED FLANGE PLUG
5	4	V20018	3/8" LOCKWASHER
6	4	V20019	3/8" HEX NUT
7	1	V20156	2" FLAT END PLATE
8	1	VL1005	FKM DECAL (N/S)



THIS DRAWING AND ALL INFORMATION CONTAINED THEREON ARE THE EXCLUSIVE PROPERTY OF BANJO CORPORATION.

UNLESS SPECIFICALLY NOTED, THIS DRAWING AND ITEMS SHOWN ON THIS DRAWING ARE SUBJECT TO CHANGE AT ANY TIME.



BANJO CORPORATION

150 BANJO DRIVE, CRAWFORDSVILLE, IN 47933
 WEB SITE: WWW.BANJOCORP.COM
 E-MAIL: BANJOSALES@IDEXCORP.COM

DESCRIPTION	2" X 2" NPT BOLTED FLANGE, FKM
PART NUMBER	BF200V