

Parts List			
ITEM	QTY	PART NUMBER	DESCRIPTION
1	2	100P	PIN
2	1	DM10151SS	1" Dry Mate Stem
3	2	DM10281	SS Spring
4	1	V20207A	Polyurethane Lanyard
5	1	VSS10020	7/16" - 20 18-8SS Jam Nut
6	1	VSS10021	7/16" Lockwasher
7	1	VSS10060	1" SS Thrust Washer
8	1	VSS10159	1" SS Gland Nut
9	1	VSS10160F	Female Stem Packing
10	1	VSS10160M	Male Stem Packing
11	1	VSS10204	1" SS Body Gasket
12	1	VSS10255	1" SS Ball
13	1	VSS10258	1" SS Valve Seat
14	2	DM100K	1" DRYMATE CAM ARM
15	1	DM10254FSS	1" SS Female Dry Mate Body
16	1	DM10154SS	DM100SS INTERLOCK CAM, FEMALE
17	1	DM10153FSS	DM100SS INTERLOCK CAM, FEMALE
18	1	DM10296	1" DRYMATE SEAL
19	1	DM10289SS	1" DRYMATE LOCKING YOKE
20	1	DM10288SS	1" DRYMATE HANDLE INTERLOCK BUTTON
21	1	DM10258	1" Drymate Teflon Seat
22	1	DM10256SS	1" DRYMATE ENDPLATE
23	1	DM100PL	1" DRYMATE DUST PLUG

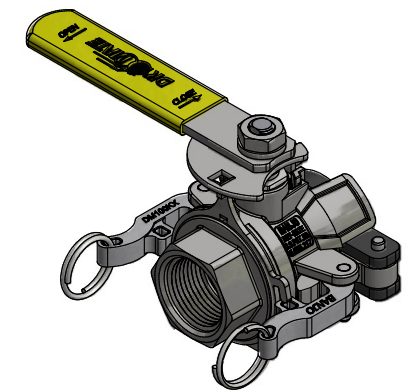

THIS DRAWING AND ALL INFORMATION CONTAINED THEREON ARE THE EXCLUSIVE PROPERTY OF BANJO CORPORATION.

UNLESS SPECIFICALLY NOTED, THIS DRAWING AND ITEMS SHOWN ON THIS DRAWING ARE SUBJECT TO CHANGE AT ANY TIME.

**BANJO CORPORATION**  
 150 BANJO DRIVE, CRAWFORDSVILLE, IN 47933  
 WEB SITE: WWW.BANJOCORP.COM  
 E-MAIL: SALES1@BANJOCORP.COM

DESCRIPTION  
 1" FMLE DRYMATE W/ 1" NPT FPT KALREZ, SS

PART NUMBER  
 DM100DSST