

HANDLE IN OPEN POSITION

HANDLE IN CLOSED POSITION

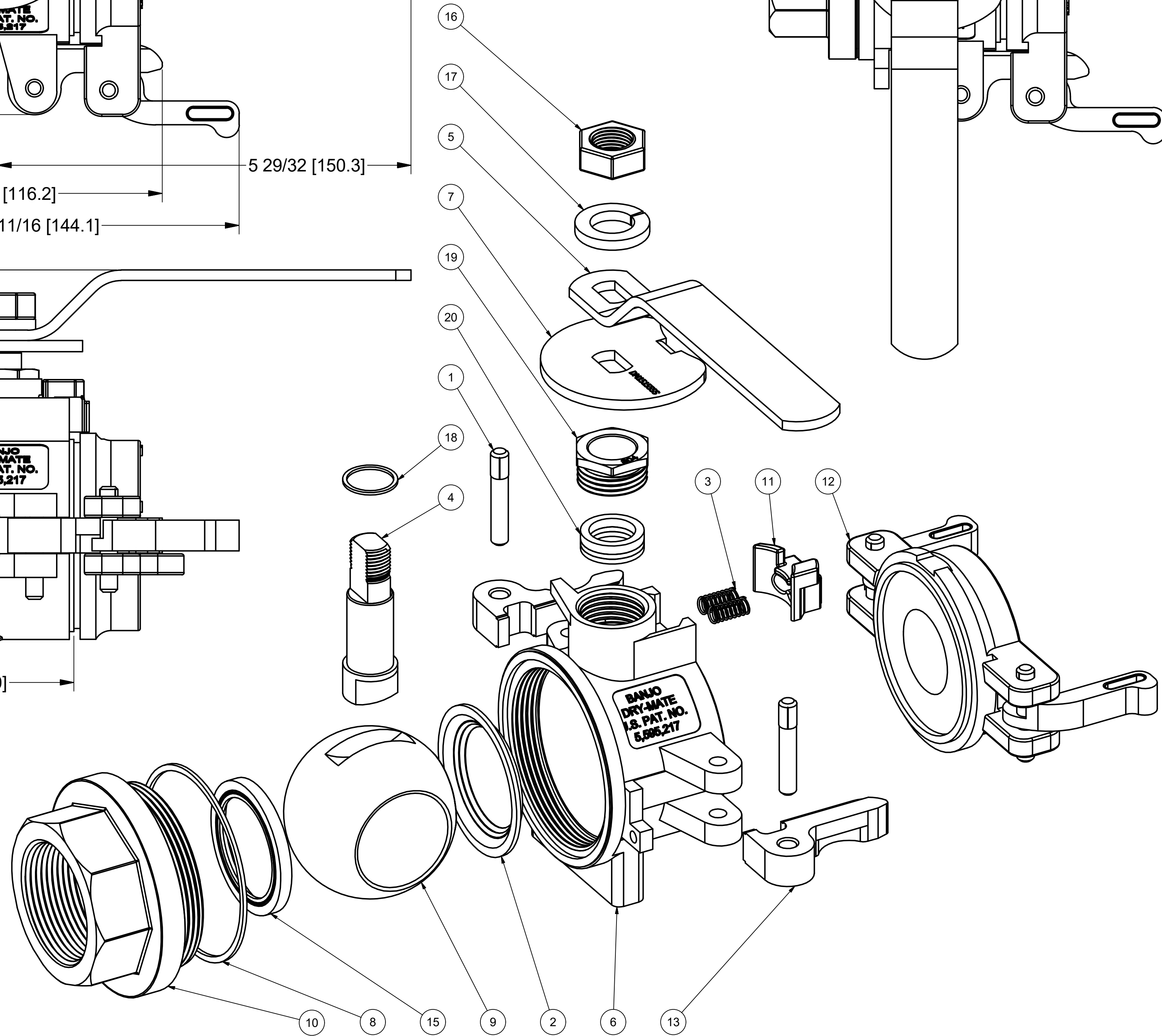

Parts List			
ITEM	QTY	PART NUMBER	DESCRIPTION
1	2	200P	CAM ARM PIN
2	1	DB20258	2" DRYMATE TEFLON SEAT
3	2	DB20281	Dry Mate Handle Interlock Spring
4	1	DM15151SS	1 1/2" SS DM Stem
5	1	DM15153SS	2" Dry Mate Male Handle
6	1	DM15154MSS	1-1/2" & 2" MALE DRYMATE BODY
7	1	DM15155SS	DM200SS INTERLOCK CAM, MALE
8	1	DM15204SS	DM150 BODY GASKET
9	1	DM15255MSS	1 1/2" Male Dry Mate Ball
10	1	DM15257MSS	1-1/2" FNPT MALE DRYMATE ENDPLATE
11	1	DM15288SS	ANTI ROTATION BUTTON 316SS
12	1	DM200ACAP	2" DRYMATE CAP ASSY
13	2	DM20300	2" DRYMATE PROFILE INSERT
14	1	V20207A	Polyurethane Lanyard
15	1	V20258	2" Ball Seat
16	1	VSS15020	5/8"-18 SS Jam Nut
17	1	VSS15021	5/8" Lock Washer
18	1	VSS15060	2" SS Thrust Washer
19	1	VSS15159	1 1/2" SS Gland Nut
20	1	VSS15160	TFE Stem Packing

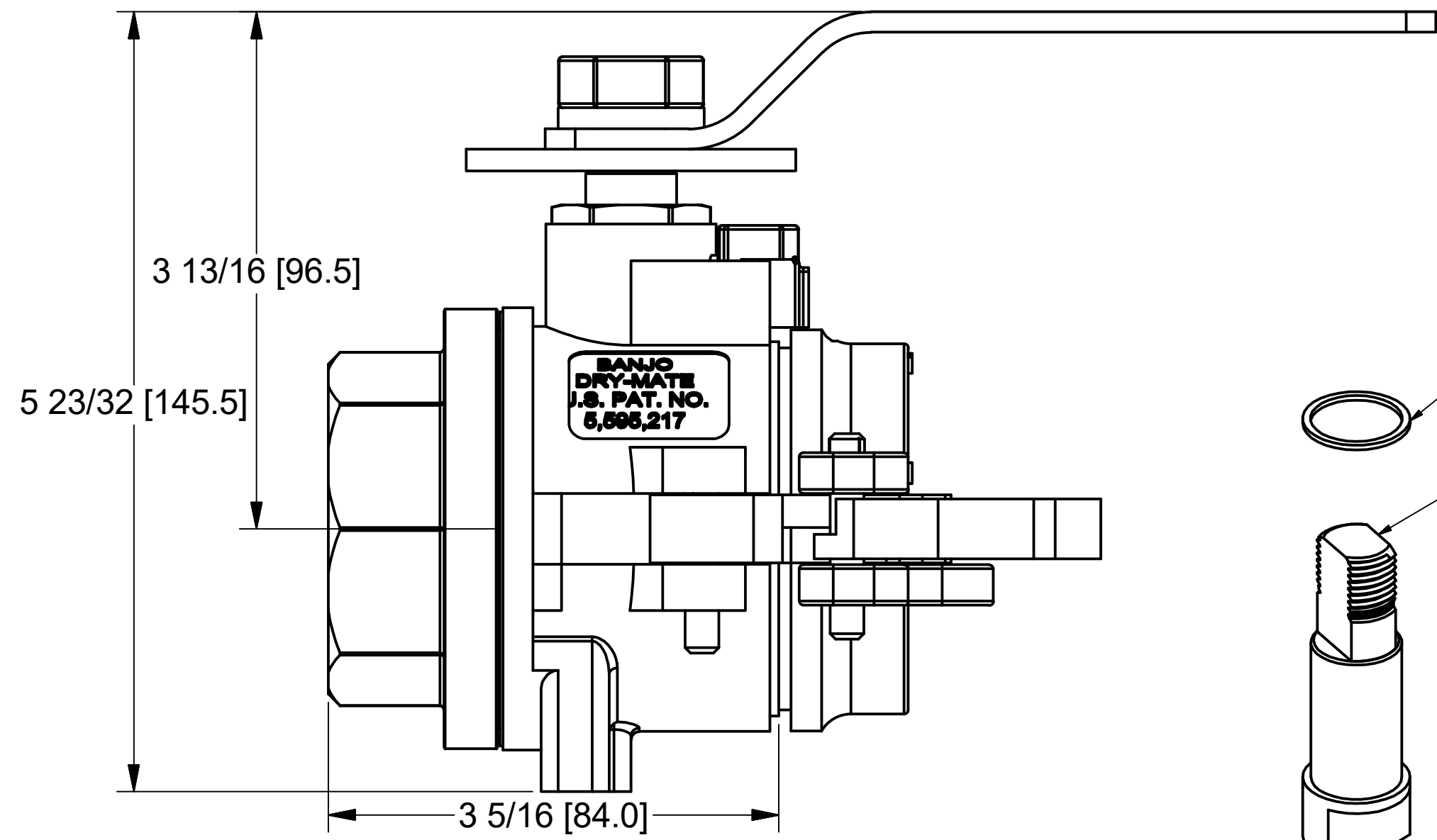
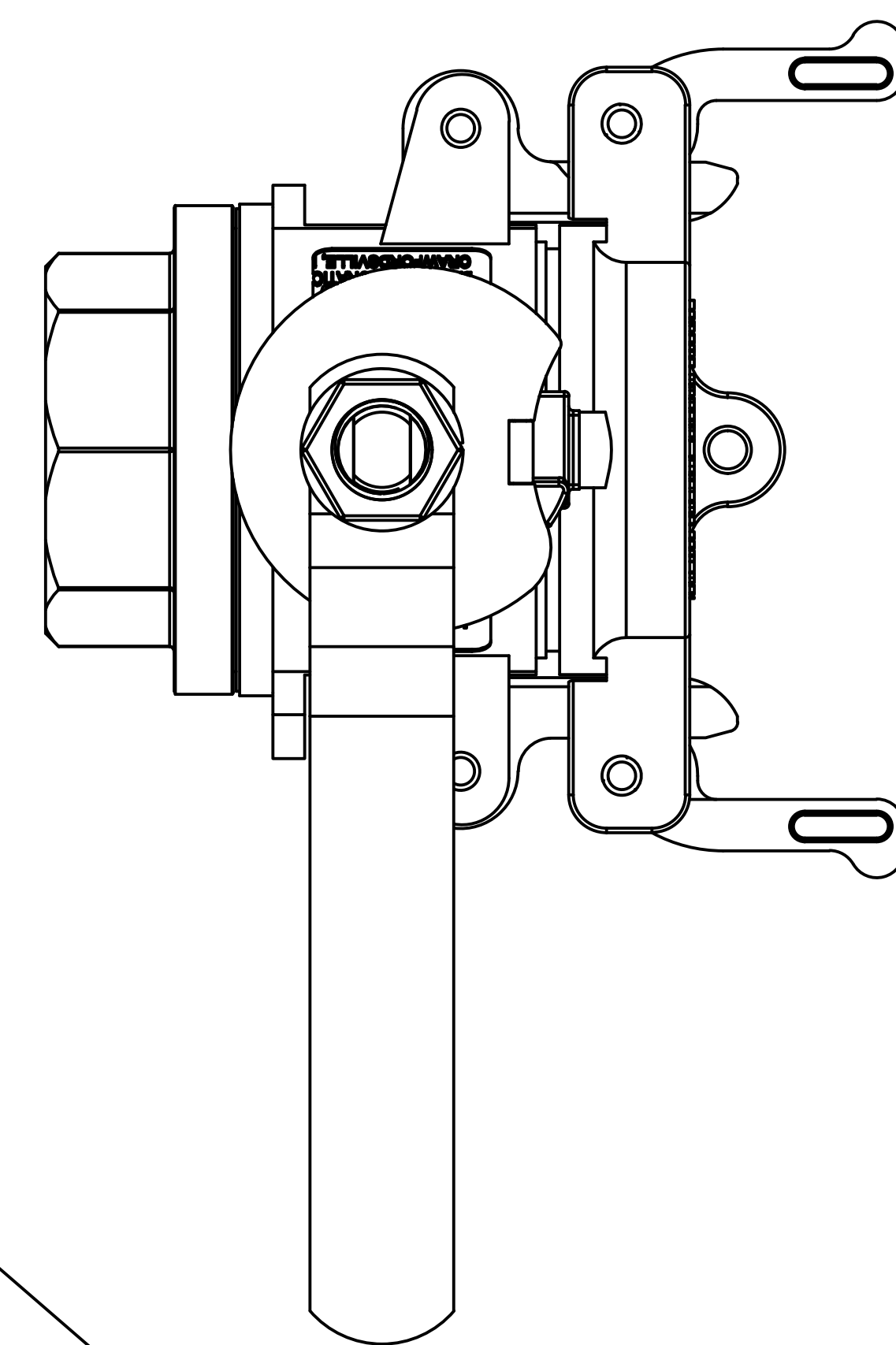
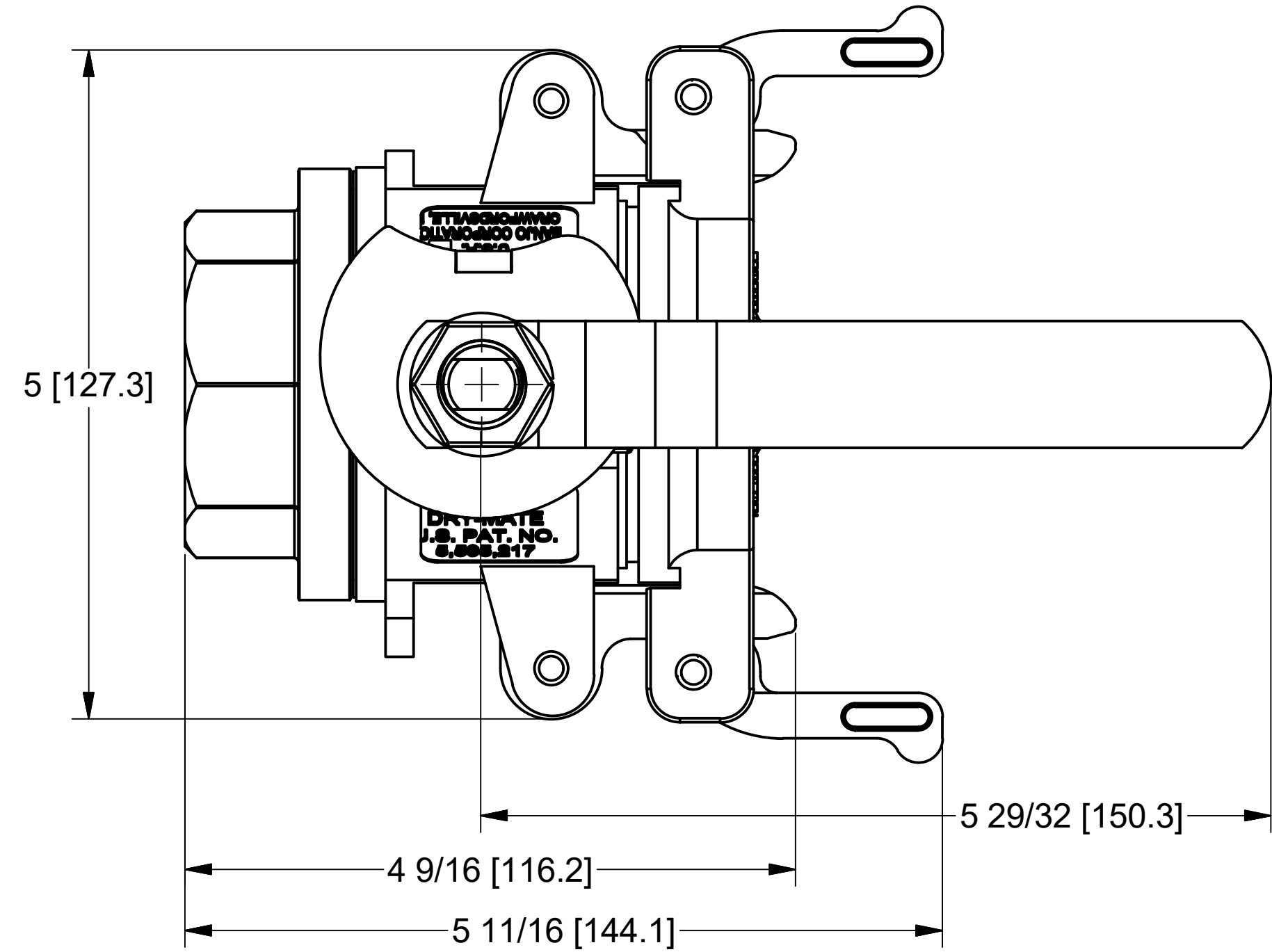

THIS DRAWING AND ALL INFORMATION CONTAINED THEREON ARE THE EXCLUSIVE PROPERTY OF BANJO CORPORATION.

UNLESS SPECIFICALLY NOTED, THIS DRAWING AND ITEMS SHOWN ON THIS DRAWING ARE SUBJECT TO CHANGE AT ANY TIME.

BANJO CORPORATION
 150 BANJO DRIVE, CRAWFORDSVILLE, IN 47933
 WEB SITE: WWW.BANJO.CORP.COM
 E-MAIL: BANJOSALES@DEXCORP.COM

DESCRIPTION
 1 1/2" FNPT MALE SS DRYMATE

PART NUMBER
 DM150ASS