

HANDLE IN CLOSED POSITION

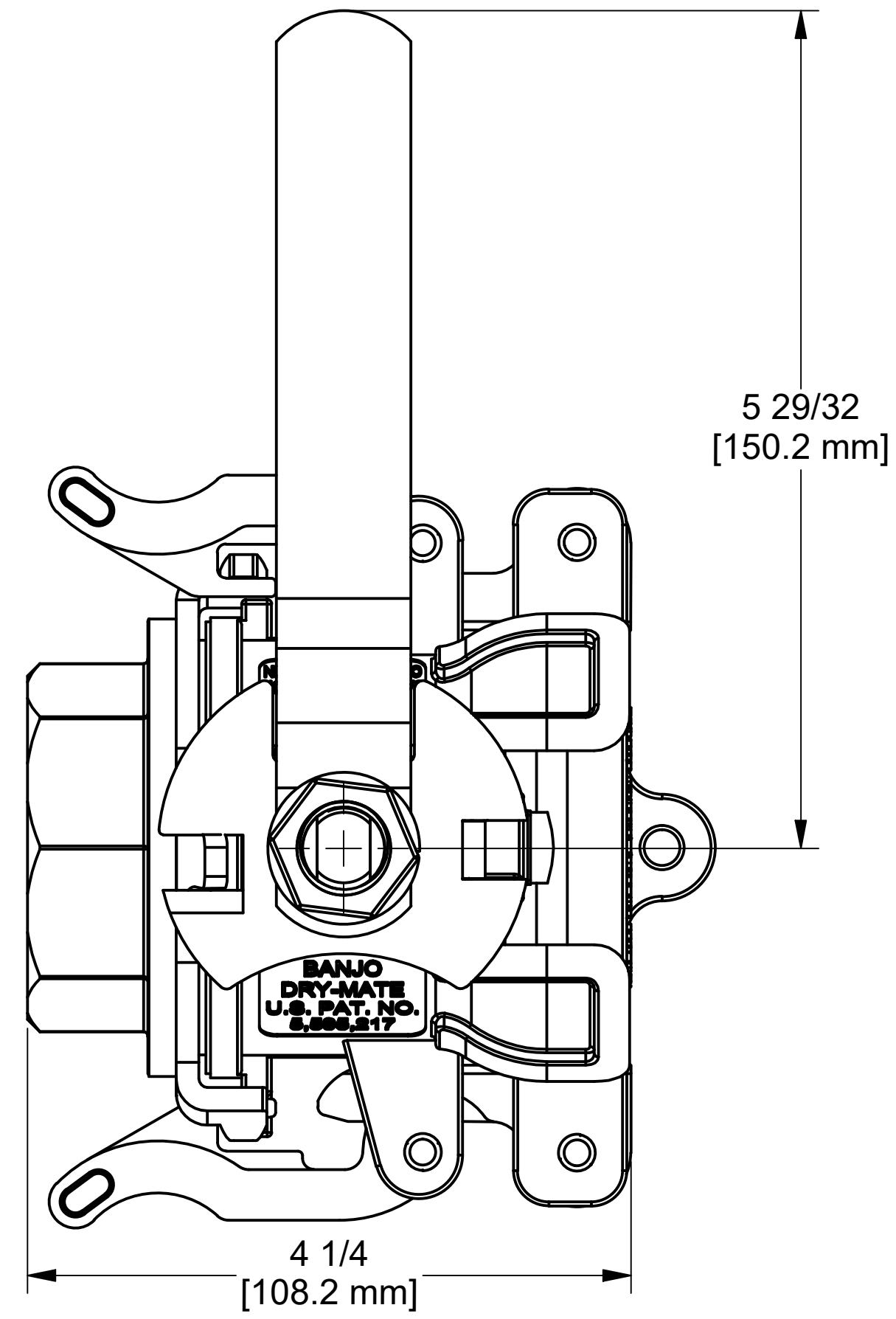

HANDLE IN OPEN POSITION

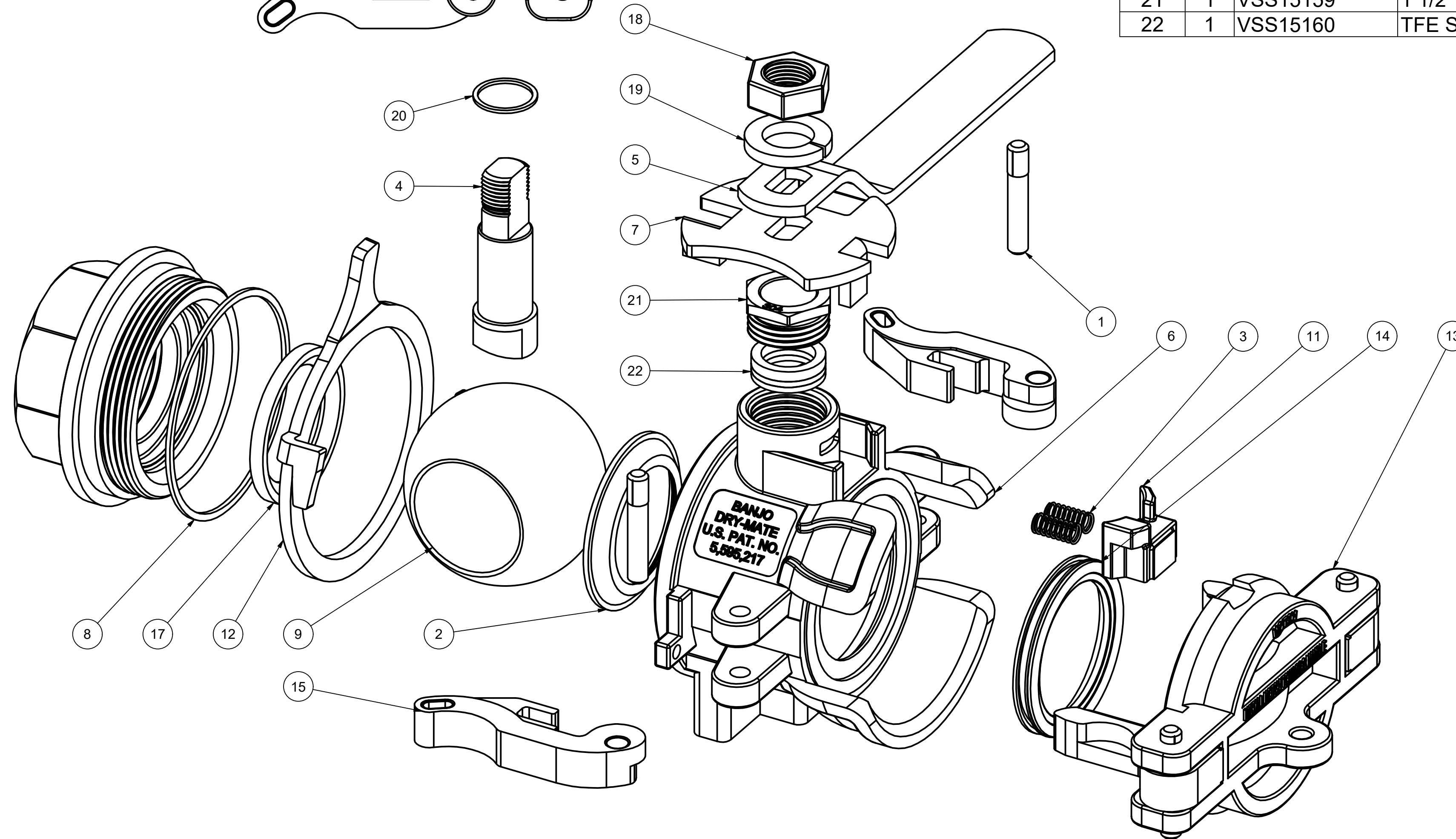
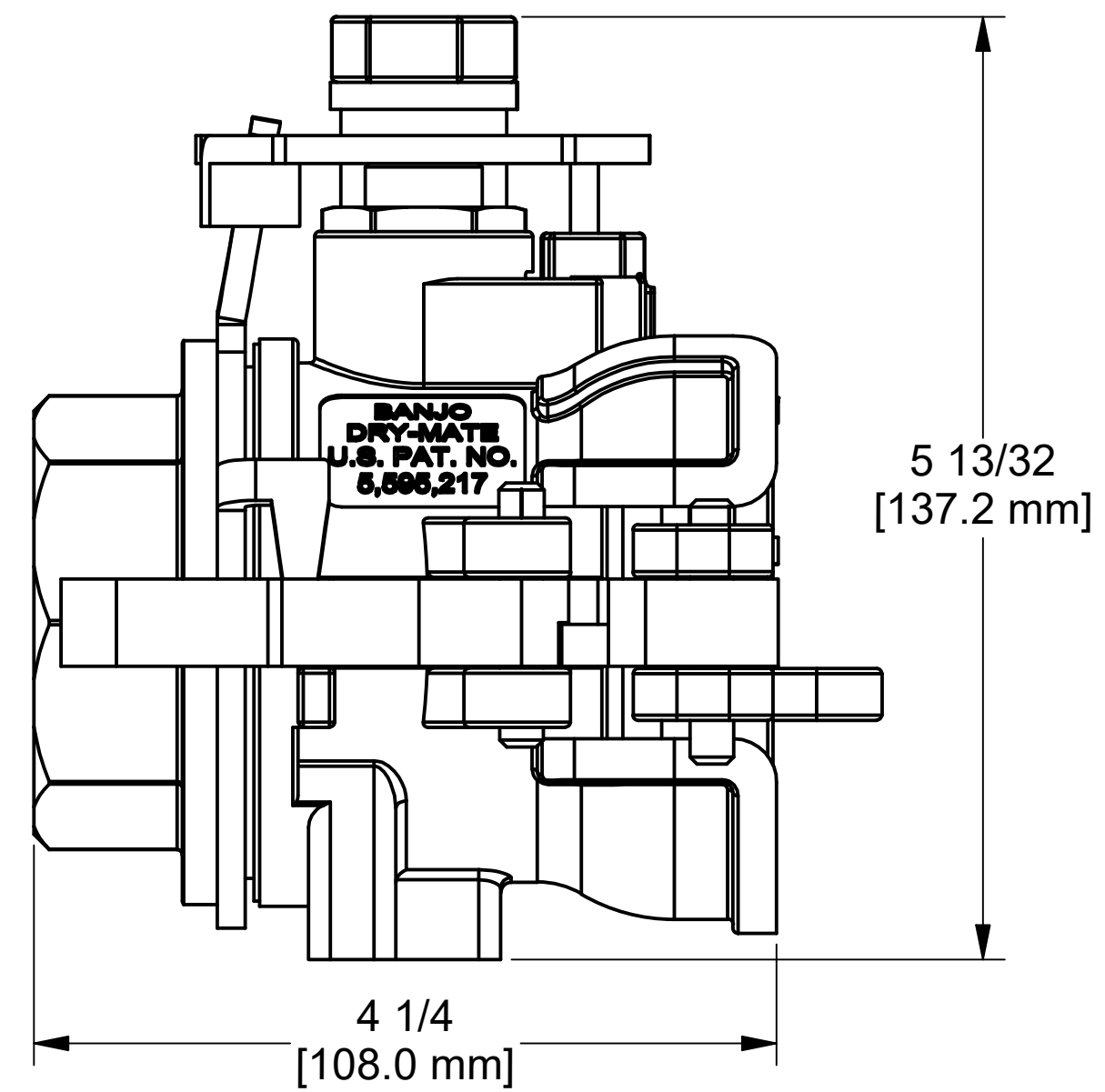
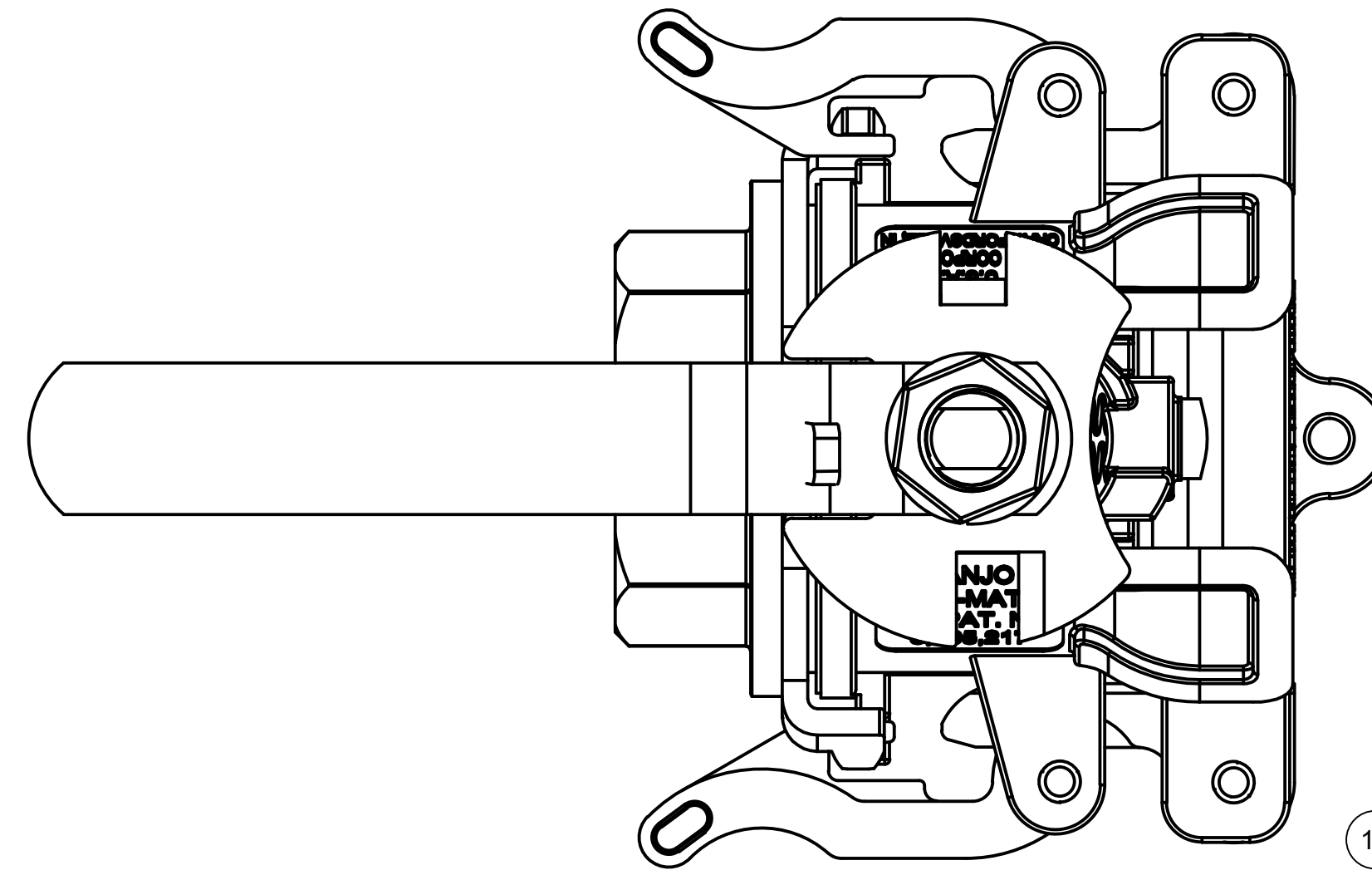

Parts List			
ITEM	QTY	PART NUMBER	DESCRIPTION
1	2	200P	CAM ARM PIN
2	1	DB20258	2" DRYMATE TEFLON SEAT
3	2	DB20281	Dry Mate Handle Interlock Spring
4	1	DM15151SS	1 1/2" SS DM Stem
5	1	DM15153SS	2" Dry Mate Male Handle
6	1	DM15154FSS	1-1/2" & 2" FEMALE SS DRYMATE BODY
7	1	DM15154SS	DM200SS Interlock Cam, Female
8	1	DM15204SS	DM150 BODY GASKET
9	1	DM15255FSS	1 1/2" SS Female Drymate Ball
10	1	DM15257FSS	1 1/2" FNPT SS FEMALE DRYMATE ENDPLATE
11	1	DM15288SS	ANTI ROTATION BUTTON 316SS
12	1	DM15289SS	1-1/2" LOCKING YOKE DM 316SS
13	1	DM200APL	2" DRYMATE PLUG ASSY
14	1	DM20294A	2" DRYMATE SEAL
15	2	DM202KX	2"DRY MATE CAM ARM 0.266 Hole
16	1	V20207A	Polyurethane Lanyard
17	1	V20258	2" Ball Seat
18	1	VSS15020	5/8"-18 SS Jam Nut
19	1	VSS15021	5/8" Lock Washer
20	1	VSS15060	2" SS Thrust Washer
21	1	VSS15159	1 1/2" SS Gland Nut
22	1	VSS15160	TFE Stem Packing



THIS DRAWING AND ALL INFORMATION CONTAINED THEREON ARE THE EXCLUSIVE PROPERTY OF BANJO CORPORATION.

UNLESS SPECIFICALLY NOTED, THIS DRAWING AND ITEMS SHOWN ON THIS DRAWING ARE SUBJECT TO CHANGE AT ANY TIME.

BANJO CORPORATION
 150 BANJO DRIVE, CRAWFORDSVILLE, IN 47933
 WEB SITE: WWW.BANJO.CORP.COM
 E-MAIL: BANJOSALES@DEXCORP.COM

DESCRIPTION
 1 1/2" SS FEMALE DRYMATE

PART NUMBER
 DM150DSS