

HANDLE IN CLOSED POSITION

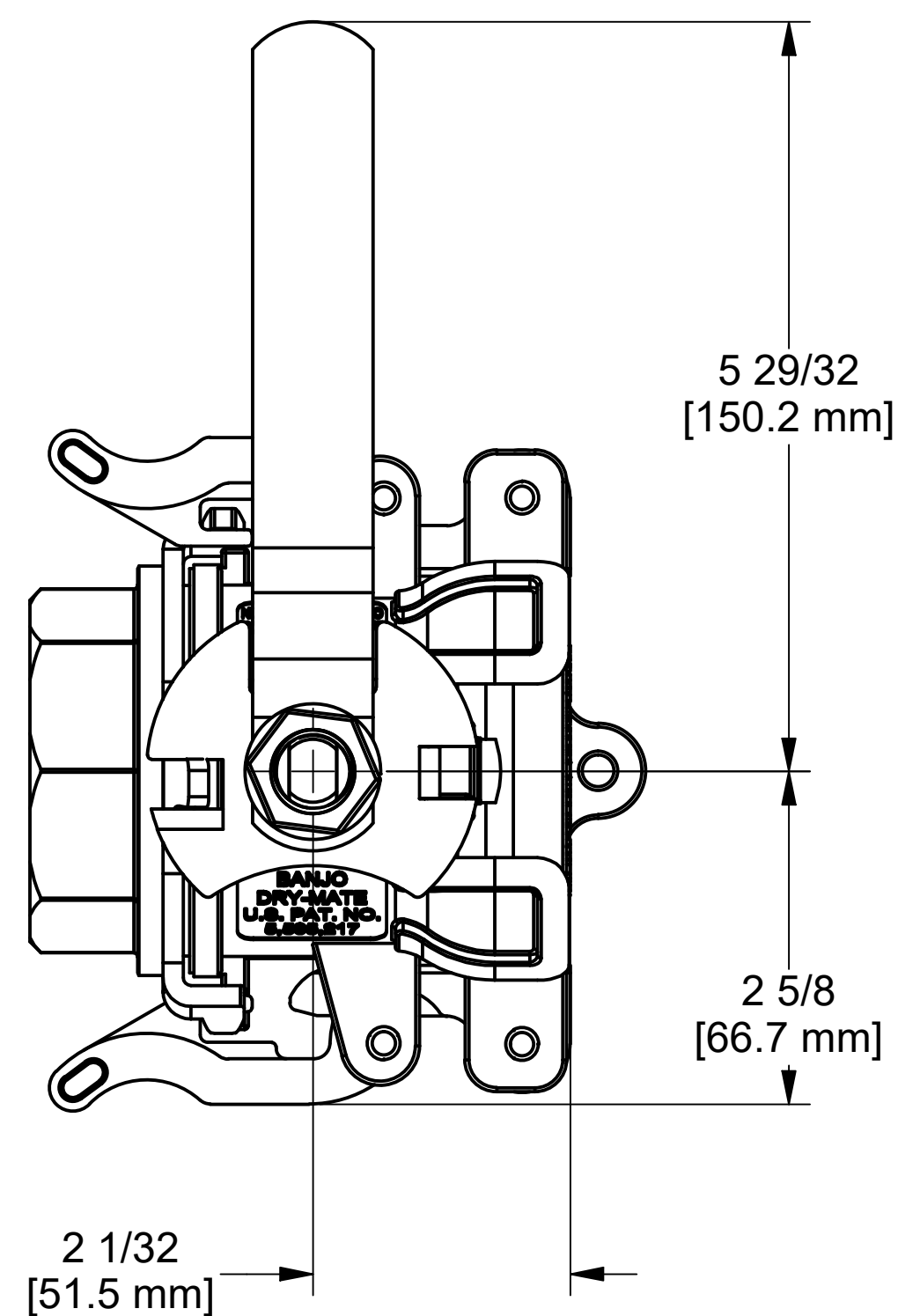

HANDLE IN OPEN POSITION

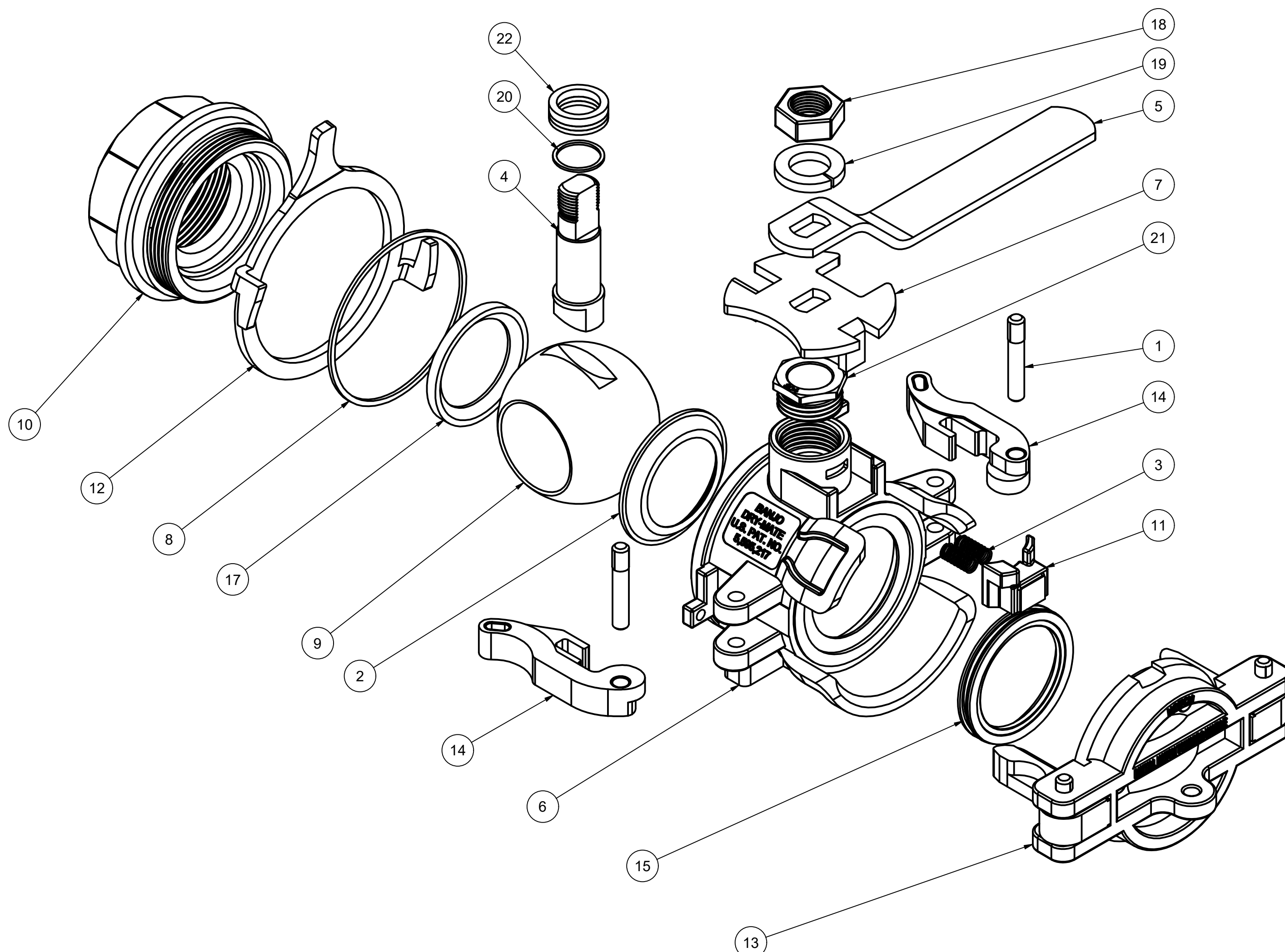
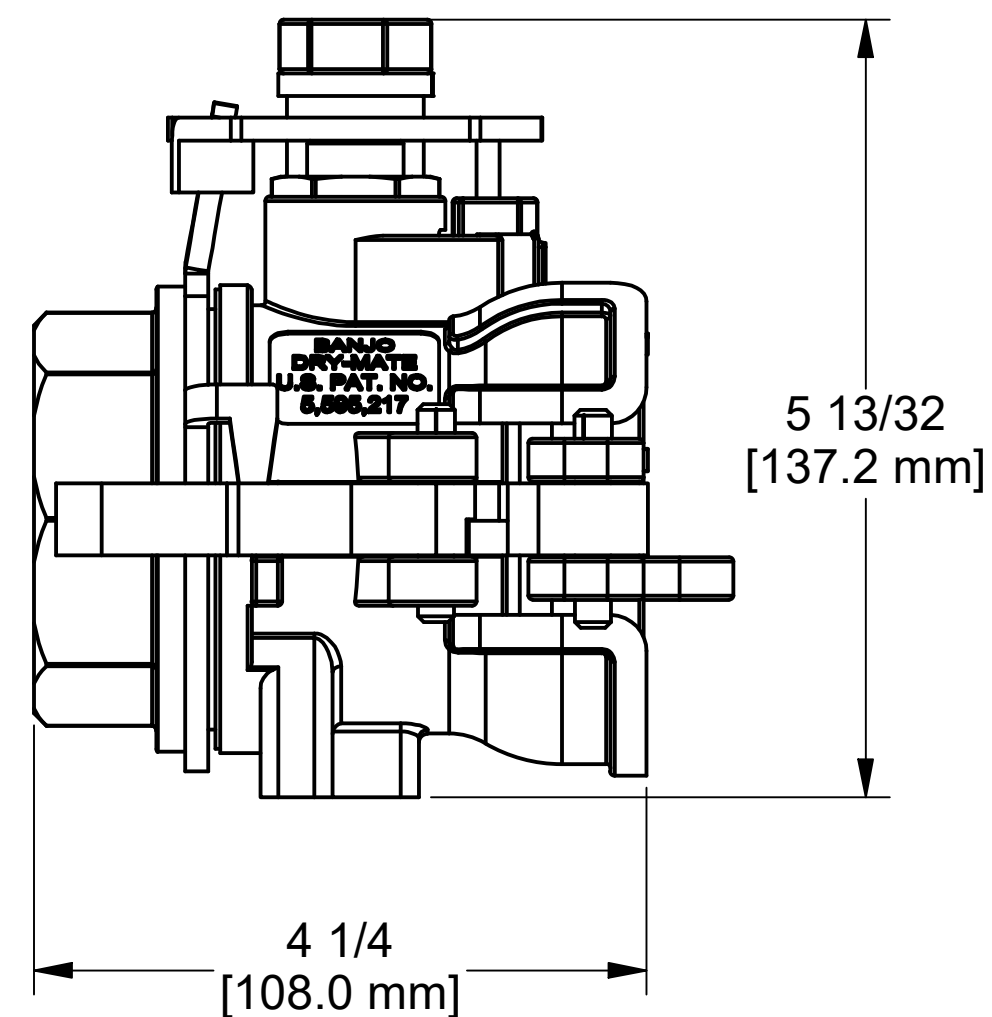
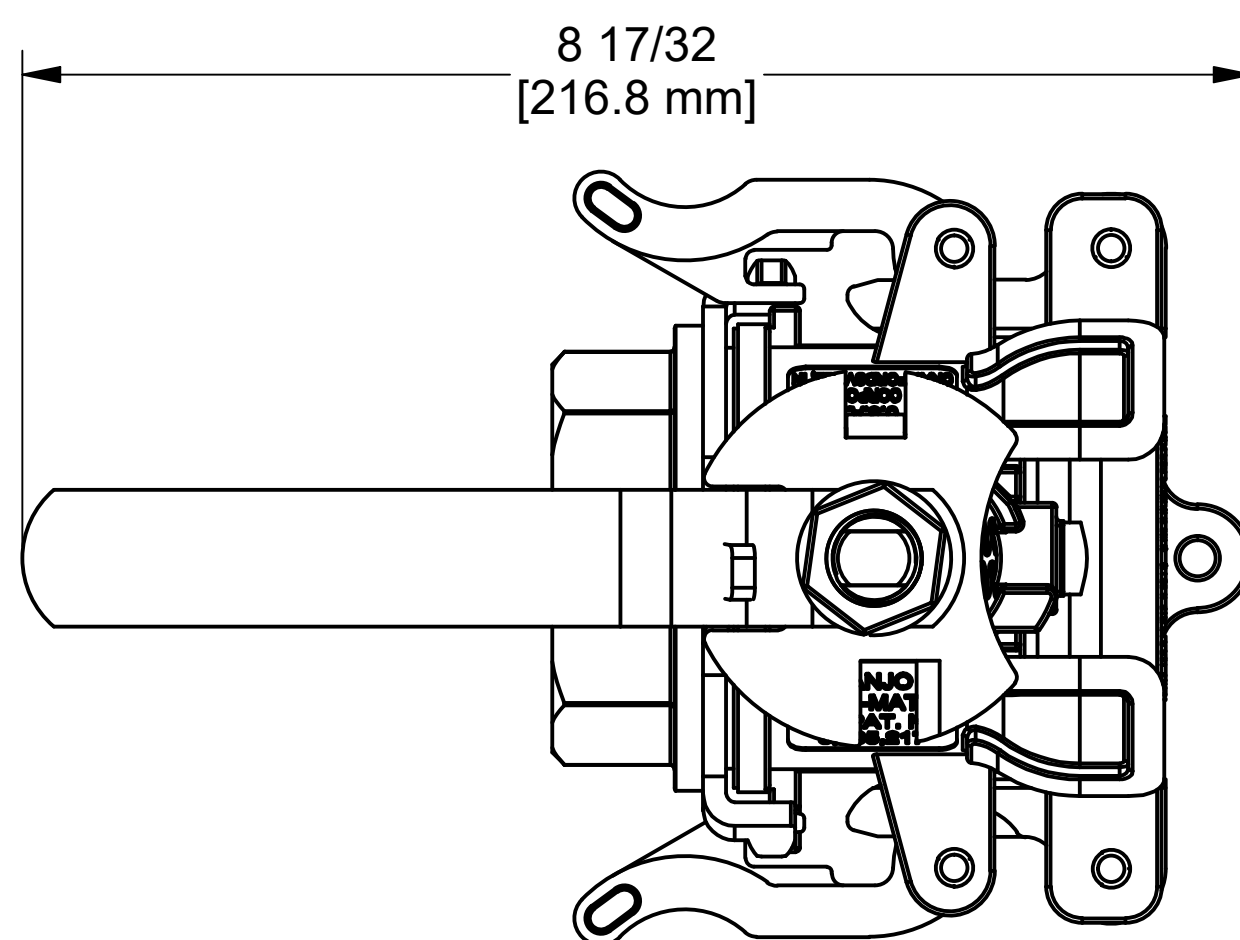

PARTS LIST			
ITEM	QTY	PART NUMBER	DESCRIPTION
1	2	200P	CAM ARM PIN, FOR 1-1/2" & 2" CAM COUPLERS
2	1	DB20258	2" DRYMATE SEAT, PTFE
3	2	DB20281	DRY MATE HANDLE INTERLOCK SPRING
4	1	DM15151SS	1 1/2" SS DM Stem
5	1	DM15153SS	2" Dry Mate Male Handle
6	1	DM15154FSS	1-1/2" & 2" FEMALE SS DRYMATE BODY
7	1	DM15154SS	DM200SS Interlock Cam, Female
8	1	DM15204SS	DM150 BODY GASKET
9	1	DM15255FSS	1 1/2" SS Female Drymate Ball
10	1	DM15256FBSS	2" FEMALE BSPP SS DRYMATE ENDPLATE
11	1	DM15288SS	ANTI ROTATION BUTTON 316SS
12	1	DM15289SS	1-1/2" LOCKING YOKE DM 316SS
13	1	DM200APL	2" DRYMATE PLUG ASSY
14	2	DM200KX	2" DRYMATE CAM ARM
15	1	DM20294A	2" DRYMATE SEAL
16	1 (NS)	V20207A	Polyurethane Lanyard
17	1	V20258	2" VALVE BALL SEAT
18	1	VSS15020	5/8"-18 SS JAM NUT
19	1	VSS15021	5/8" LOCKWASHER
20	1	VSS15060	THRUST WASHER, ID 0.676", PTFE
21	1	VSS15159	1 1/2" SS GLAND NUT
22	1	VSS15160	2" SS DM V-PACKING

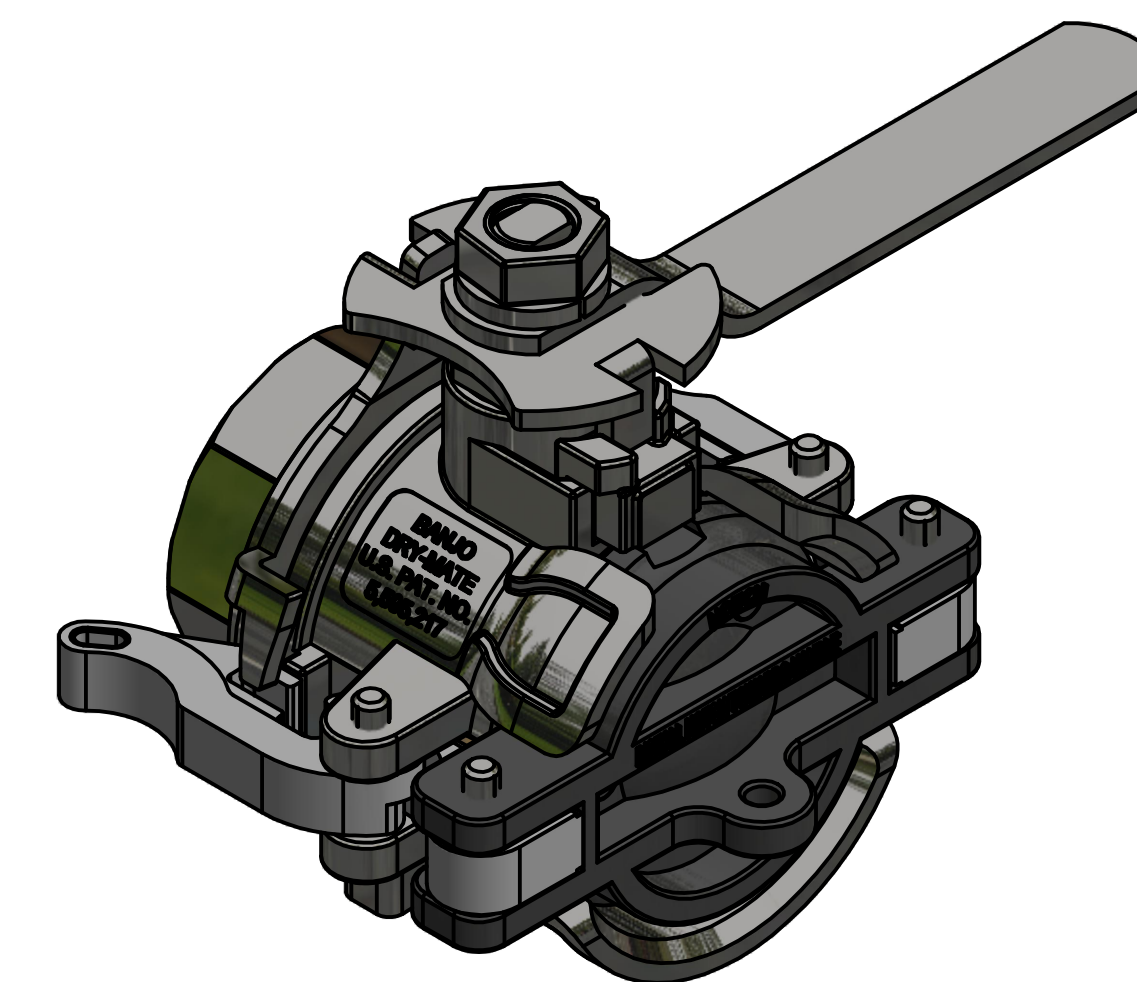

THIS DRAWING AND ALL INFORMATION CONTAINED THEREON ARE THE EXCLUSIVE PROPERTY OF BANJO CORPORATION.

UNLESS SPECIFICALLY NOTED, THIS DRAWING AND ITEMS SHOWN ON THIS DRAWING ARE SUBJECT TO CHANGE AT ANY TIME.

BANJO CORPORATION
 150 BANJO DRIVE, CRAWFORDSVILLE, IN 47933
 WEB SITE: WWW.BANJO.CORP.COM
 E-MAIL: BANJOSALES@DEXCORP.COM

DESCRIPTION
 2" SS SP FEMALE x FEMALE BSPP w/
 FKM SEALS

PART NUMBER
 DM200DBSS