

PARTS LIST			
ITEM	QTY	PART NUMBER	DESCRIPTION
1	2	DB20281	DRY MATE HANDLE INTERLOCK SPRING
2	1	DM220CAP	2" FP SS DM DUST CAP
3	1	DM25151SS	2" FP SS DM STEM
4	1	DM25153SSM	2" FP DRYMATE MALE HANDLE
5	1	DM25155SS	2" FP MALE DRYMATE INTERLOCK
6	1	DM25204SS	DM220 BODY GASKET
7	1	DM25254MSS	2" FP MALE SS DM BODY MACHINED
8	1	DM25255SSH	2" FP DM SS HOLLOW BALL
9	1	DM25256BSS	2" FEMALE BSPP FP DRYMATE SS ENDPLATE
10	1	DM25258FV1	2" FP DM FILLED VALVE BODY SEAT
11	1	DM25258FV2	2" FP DM FILLED VALVE EP SEAT
12	1	DM25288MSS	2" FP SS DM MALE INTERLOCK BUTTON
13	1	VSS15020	5/8"-18 SS JAM NUT
14	1	VSS15021	5/8" LOCKWASHER
15	1	VSS15060	THRUST WASHER, ID 0.676", PTFE
16	1	VSS15159	1 1/2" SS GLAND NUT
17	1	VSS15160	2" SS DM V-PACKING

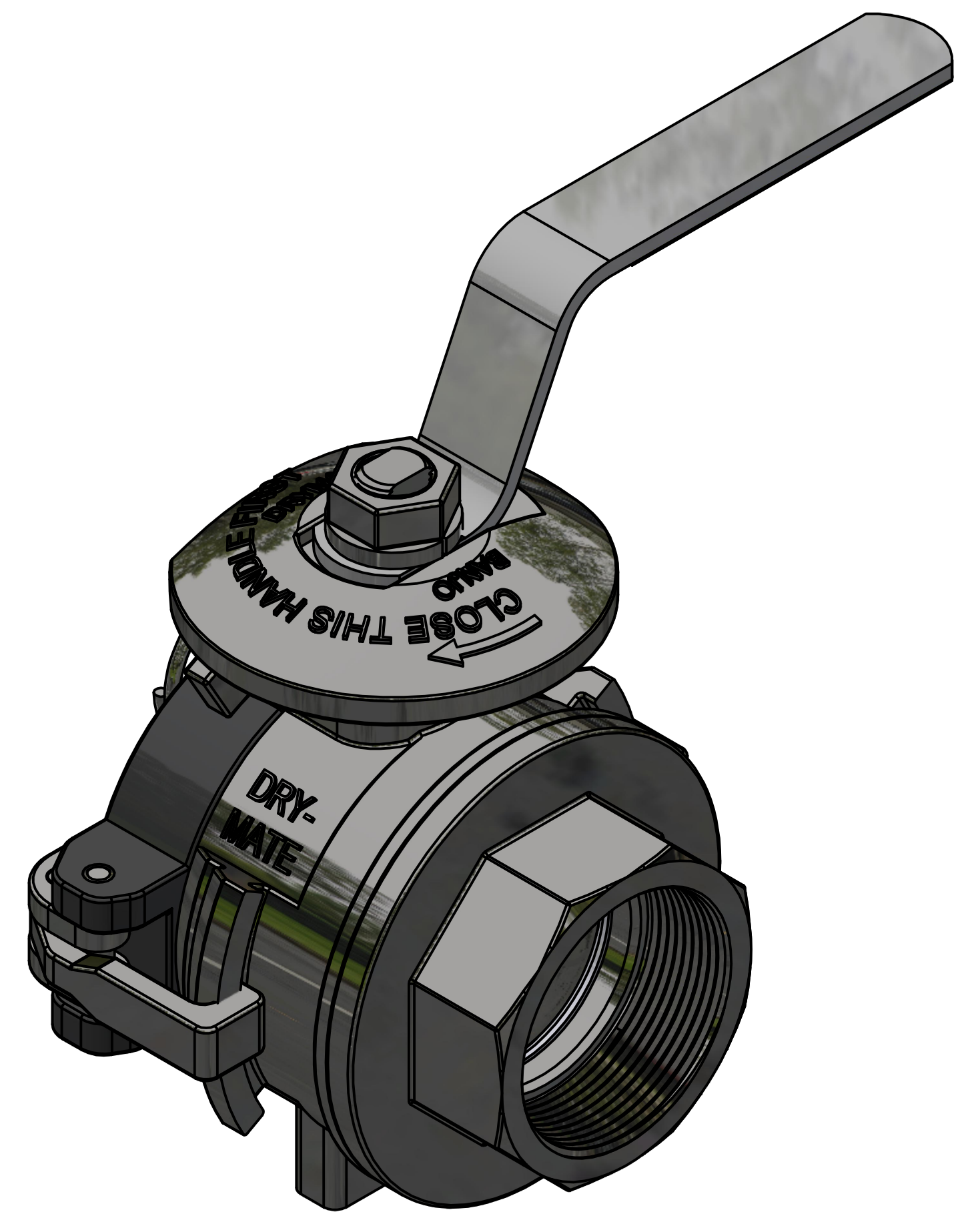

THIS DRAWING AND ALL INFORMATION CONTAINED THEREON ARE THE EXCLUSIVE PROPERTY OF BANJO CORPORATION.

UNLESS SPECIFICALLY NOTED, THIS DRAWING AND ITEMS SHOWN ON THIS DRAWING ARE SUBJECT TO CHANGE AT ANY TIME.

BANJO CORPORATION
 150 BANJO DRIVE, CRAWFORDSVILLE, IN 47933
 WEB SITE: WWW.BANJO.CORP.COM
 E-MAIL: BANJOSALES@IDEXCORP.COM

DESCRIPTION
 2" SS FP MALE x FEMALE BSPP w/ PTFE SEALS

PART NUMBER
 DM220ABSS