

4

3

2

1

Parts List

ITEM	QTY	PART NUMBER	DESCRIPTION
1	1	DM220CAPX	2" FP DM Dust Cap Unassembled
2	2	DM25011	2" FP DM Dust Cap Clamp Arm SS
3	2	DM25012SS	2" FP Drymate Cap Clamp Lever SS
4	2	DM25016	2" FP Drymate Clamp To Arm CAP Pin
5	1	150RING	LARGE CAM ARM RING
6	2	200P	CAM ARM PIN, FOR 1-1/2" & 2" CAM COUPLERS
7	1	MLS234GV	AS568A -234 O-RING, FKM, BROWN

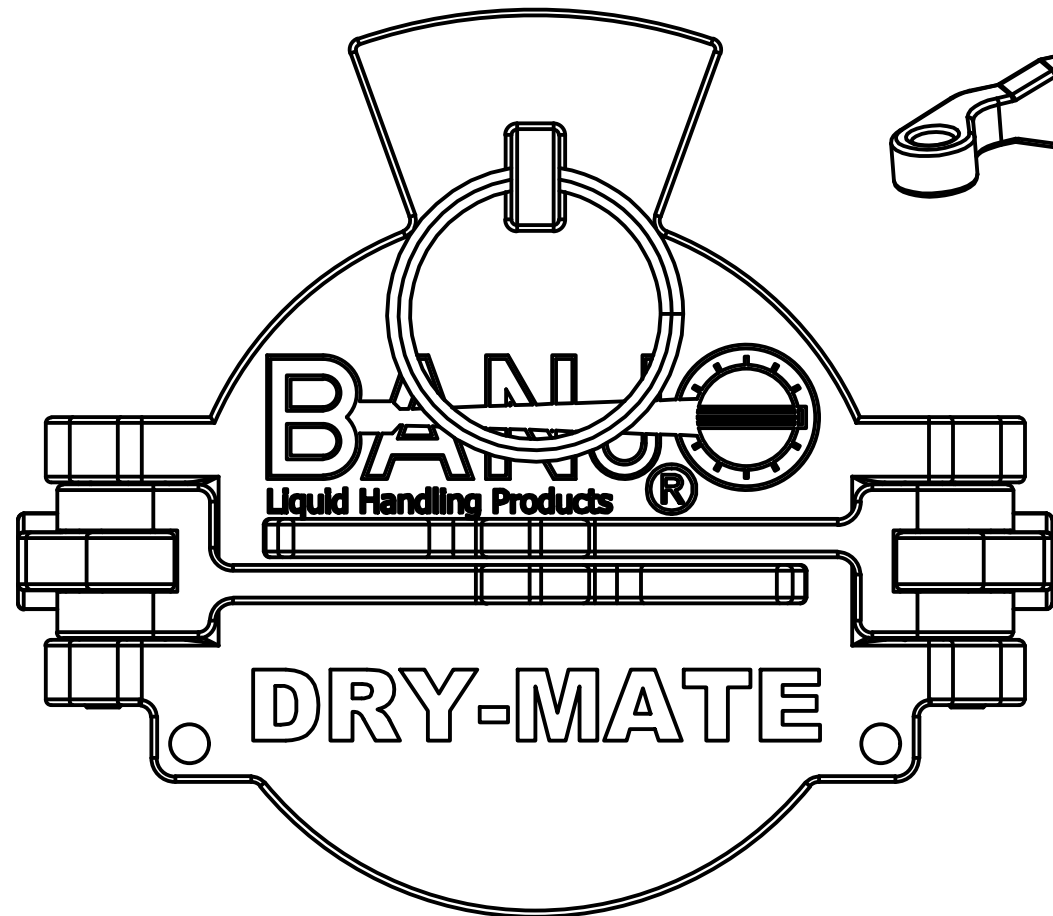
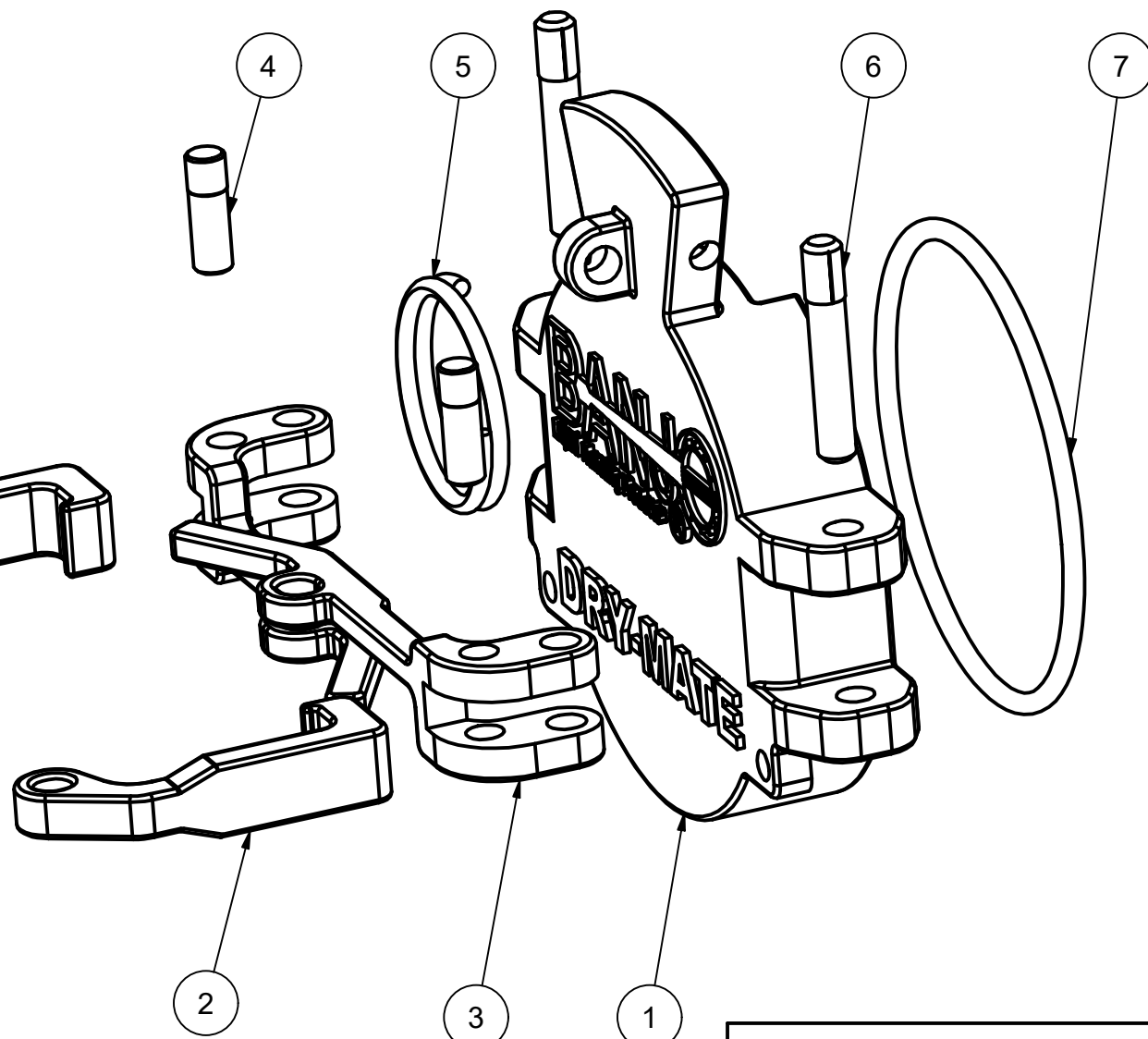
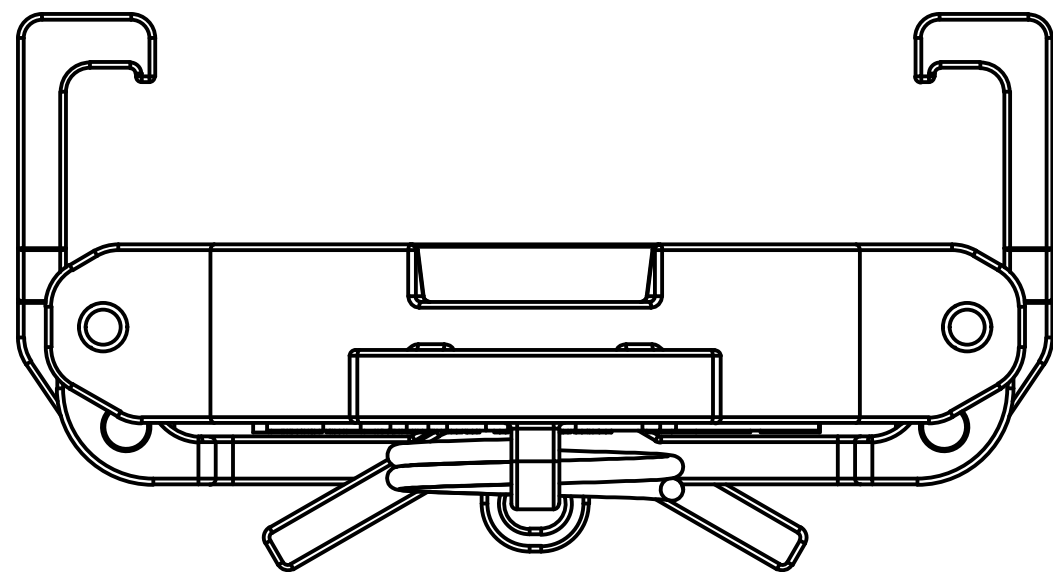

THIS DRAWING AND ALL INFORMATION CONTAINED THEREON ARE THE EXCLUSIVE PROPERTY OF BANJO CORPORATION.

UNLESS SPECIFICALLY NOTED, THIS DRAWING AND ITEMS SHOWN ON THIS DRAWING ARE SUBJECT TO CHANGE AT ANY TIME.

BANJO CORPORATION

150 BANJO DRIVE, CRAWFORDSVILLE, IN 47933
 WEB SITE: WWW.BANJOCORP.COM
 E-MAIL: BANJOSALES@IDEXCORP.COM

DESCRIPTION
 2" FP SS DM DUST CAP

PART NUMBER
 DM220CAP

4

3

2

1