



DM220 & DM300 SERIES
2" FULL PORT & 3" FULL PORT
POLYPROPYLENE



OVERVIEW AND FEATURES

The Banjo DM220 & DM300 Series of dry quick disconnect fittings are designed to handle many of the industrial chemicals in use today with a minimum of fluid spillage. The easy to use ball valve design of the fittings allows an unrestricted path for fluid flow.

The handles interlock making it easy to identify which handle opens or closes first.

The Dry-Mate is constructed of glass-reinforced polypropylene for strength and excellent chemical resistance. The PTFE seats and FKM face seal on the female give the Dry-Mate the same chemical resistance as Banjo's standard line of ball valves. The face seal on the female is available in FKM, EPDM and PTFE. The male has all PTFE sealing components.

The over center clamps are easy, quick and positive engagement of the Dry-Mate components. The clamps are 316 stainless steel for maximum corrosion resistance. The clamps are easily replaceable if damaged.

The Female* has a groove that mates to a rib on the male to provide correct alignment during assembly with the Male**. The two halves may be rotated 10 degrees either direction with respect to each other and still be clamped together and function properly.

The DM220 & DM300 Series have many safety features to reduce the risk of accidental spillage. Both handles have interlock buttons, which prevent the handles from opening when the halves are separated and the handles are in the fully closed position. The Female also has a yoke which keeps the clamp arms in the locked position when the couplers are connected and the handle is in the fully open position. This prevents the couplers from being separated when the handles are in the fully open position. The gasket that seals between the two components is mechanically secured to ensure that the gasket stays in place when the halves are disconnected.

Both the Male and Female come standard with a dust cover to keep the balls and seals protected when not in use.

SPECIFICATIONS

Maximum Pressure 225 PSI @ 70° F Minimum Temperature -20°F @ 100 PSI Maximum Temperature 150° @ 100 PSI

PART NO	DESCRIPTION	MAX PSI	PIPE SIZE	OPENING THRU BALL
DM220AD	2" Poly Dry-Mate Set	225	2"	2"
DM220A	2" Male x FPT NPT with FKM Seals	225	2"	2"
DM220AB	2" Male x FPT BSP with FKM Seals	225	2"	2"
DM220ACF	2" Flanged Male with FKM Seals	225	2"	2"
DM220D	2" Female x FPT NPT with FKM Seals	225	2"	2"
DM220DB	2" Female x FPT BSP with FKM Seals	225	2"	2"
DM220DCF	2" Flanged Female with FKM Seals	225	2"	2"

*Female refers to DM220D variants. **Male refers to DM220A variants.



Dry Mate Dry Disconnects should be used, inspected, serviced and rebuilt only by persons who have been properly trained and instructed on their use, inspection, servicing and rebuilding.

PART NO	DESCRIPTION	MAX PSI	PIPE SIZE	OPENING THRU BALL
DM300AFP	3" Full Port Male x 3" Female NPT Threads with FKM Seals	150	3"	3"
DM300ABFP	3" Full Port Male x 3" BSP Threads with FKM Seals	150	3"	3"
DM300ACF	3" Flanged Male with FKM Seals	150	3"	3"
DM300DFP	3" Full Port Female x 3" Female NPT Threads with FKM Seals	150	3"	3"
DM300DBFP	3" Full Port Female x 3" Female BSP Threads with FKM Seals	150	3"	3"
DM300DCF	3" Flanged Female with FKM Seals	150	3"	3"

*Female refers to DM300D variants. **Male refers to DM300A variants.



WARNING!

The Banjo DM220 and DM300 Series should not be used at pressures above the Maximum Pressure or at temperatures above the Maximum Temperature or below the Minimum Temperature indicated. Use outside of these parameters could cause failure of the fittings, which may result in significant injury or death.

Although sold separately, the Male should only be used with the Female, and the Female should only be used with the Male.

The Banjo DM220 and DM300 Series should not be used with chemicals or other fluids with which it is not compatible. Before use, confirm compatibility of the chemical or other fluid being transferred with the materials used in the Banjo DM220 and DM300 Series.

INSTALLATION

When installing the couplers, use a good quality thread sealant compatible with the liquid being used in the system. Screw the coupler onto the thread hand tight; using a wrench, tighten the coupler onto the thread another 1/4 to 1/2 turn.



WARNING!

The Male should always be installed on the high-pressure side of the system. Failure to install the Male on the high-pressure side can trap pressurized fluid between the balls, causing fluid to spray when the two halves are disconnected, which may result in significant injury or death!

Never open Male or Female couplings when disconnected. High-pressure fluid can be retained inside valve causing injury if opened while not connected to a mating coupler. Inspect all safety interlocks daily. If any of the safety features are not functioning or are damaged, unit must be repaired before using in service. Inspect clamps and mating ribs for damage and wear. Bent or damaged parts as well as excessive wear can adversely affect product performance. Inspect seals and sealing area on faces of couplers for any signs of damage. All surfaces should be clean and damage free prior to connection.

OPERATION

Step 1

To attach the two halves together, make sure the faces of the Male and Female are free from dirt or other foreign material. Align the two halves together as shown in Figure 1. The two halves can be rotated 10 degrees either direction with respect to each other as shown in Figure 2.

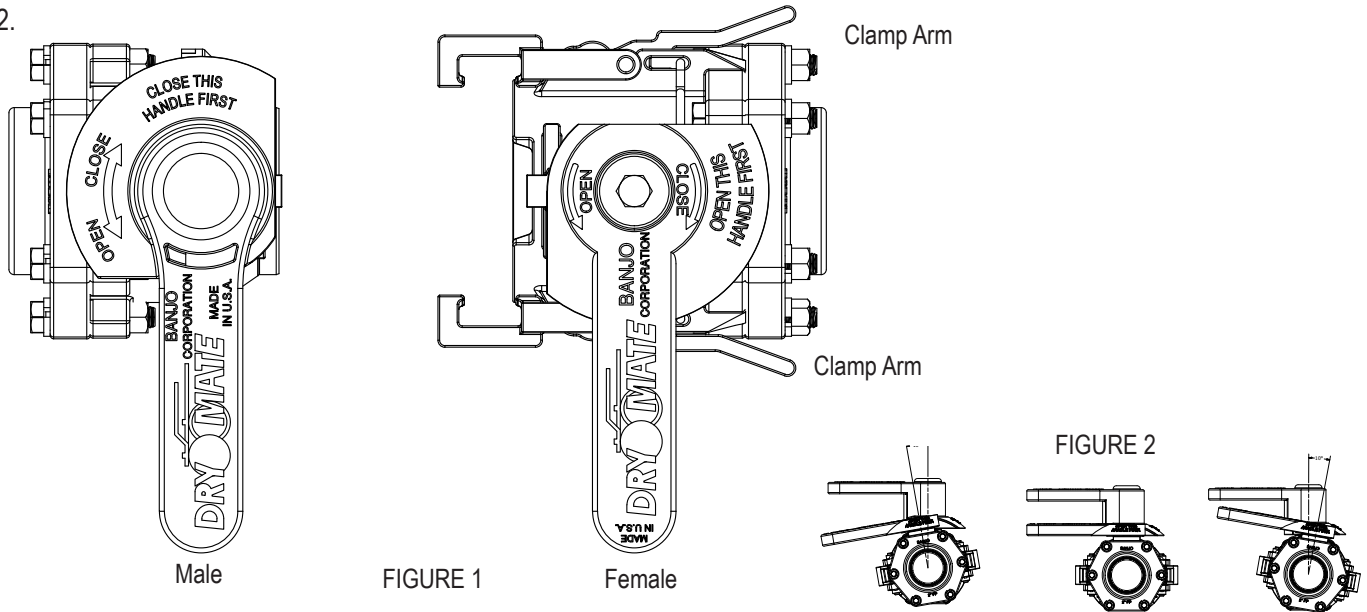

Step 2

Slide the Female onto the Male. The alignment groove on the Female will guide the male half into the female half. After the assembly is together, latch the clamp arms onto the mating rib on the male and rotate the clamp lever toward the female body. This will couple the halves together and depress the anti-rotation buttons under the handles, which will allow the handles to rotate. After the two halves are clamped together, the assembly should look like Figure 3.

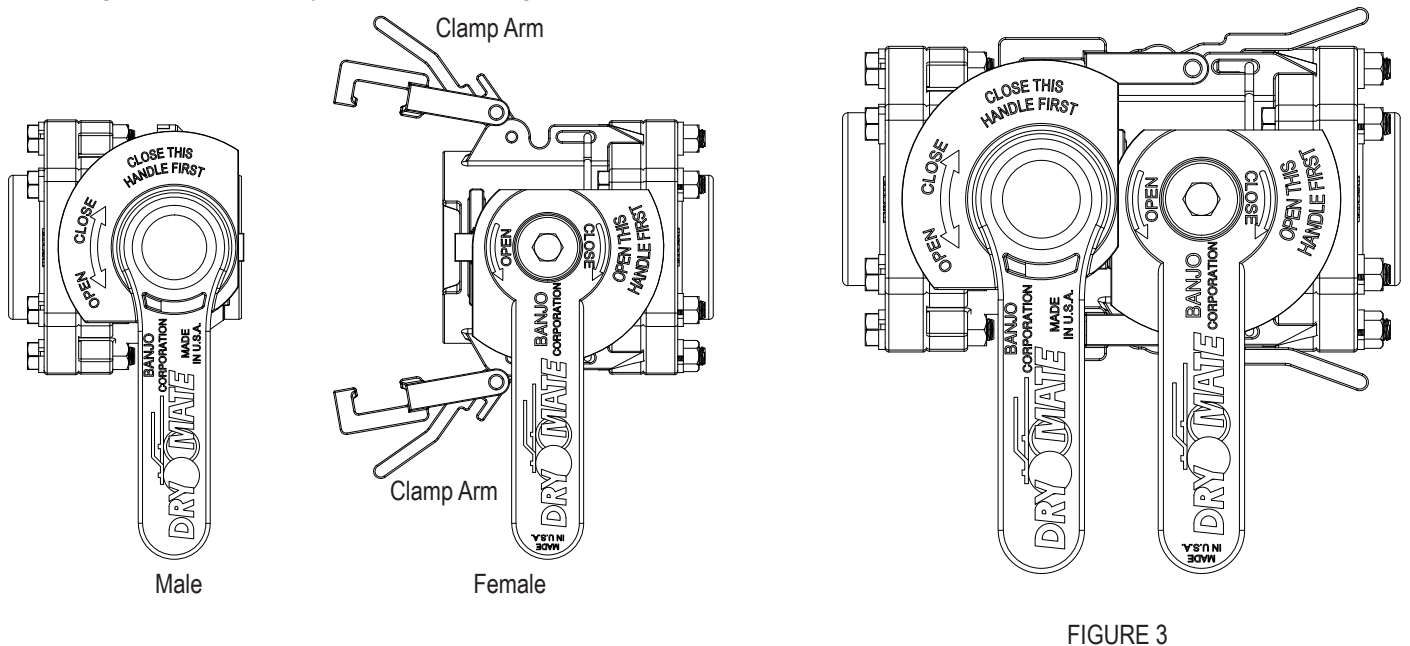

WARNING!

Make sure the clamp arms are in the fully locked position as shown in Figure 3 before attempting to rotate the handle of either the Male or Female.

Step 3

In this position, the handle of the Female must be rotated before the handle of the Male can rotate. Rotate the handle of the Female to the fully open position. When this handle is fully opened, the locking yoke will engage the cam levers and prevent the cam levers from being opened while the handle is in the fully open position. The handles should now be oriented as shown in Figure 4.

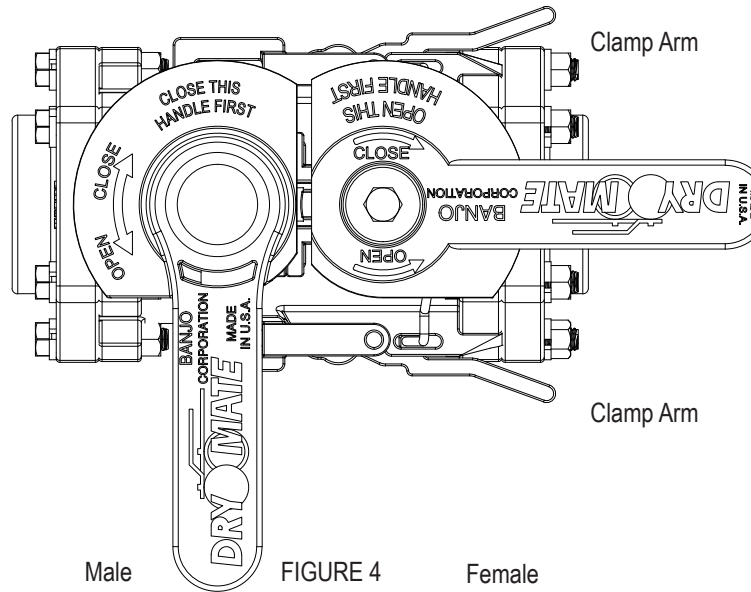

Step 4

After the handle of the Female has been fully opened, the handle of the Male can be rotated. Rotate the handle of the Male to the fully open position. The assembly is now opened and flow may begin. When both valves are fully opened the handles should be oriented as shown in Figure 5.

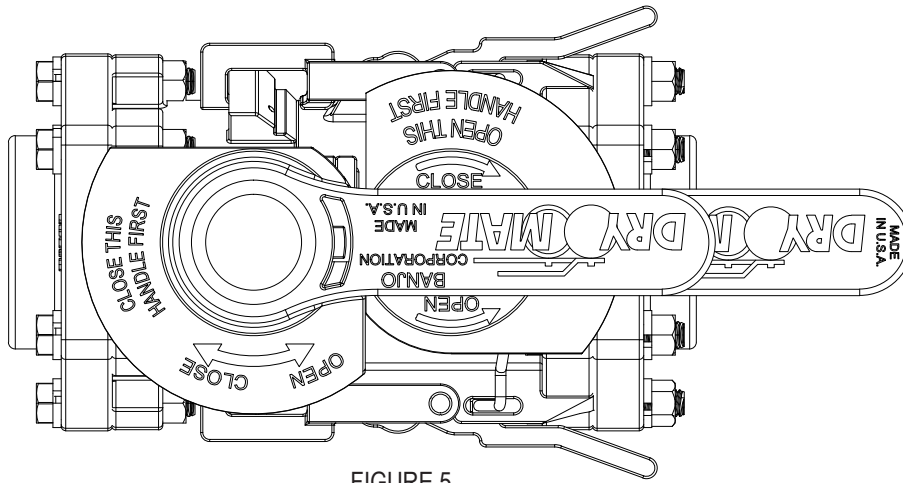

To close the valves and disconnect the couplers, reverse steps 1 through 4.

WARNING!

As the handle of the Female is being closed and before the handle is fully closed, the locking yoke that prevents the cam levers from being opened will disengage.

Make sure that the handle on the Female is fully closed before opening the cam levers.

If the cam levers are opened before the handle of the Female is fully closed, liquid may spray or be discharged, which may result in significant injury or death.



DISASSEMBLY INSTRUCTIONS

Polypropylene Dry Mate Rebuild Instructions

1. Remove the end plate by unscrewing the six (6) bolts/nuts.
2. Remove the ball. The handle should be in the closed position when removing the ball. The ball should slide out easily.
3. Remove the old seat that goes between the body and the ball.
4. Install the new seat.
5. Reinstall the ball. Check for pits, scrapes, or any other damage. If damaged or worn, replace ball.
6. Replace old seat in end plate with new seat.
7. Inspect old body o-ring. Replace if necessary.
8. Reinstall end plate on valve. Before tightening the end plate, make sure that the handle and ball are in the closed position. Tighten end plate bolts to 100 in-lb of torque.
9. Check to make sure the dry mate half is functional and all the safety features are working properly.

Polypropylene Dry Mate Face Seal Replacement Instructions

(Applies to Female (D) half only!)

1. Remove old face seal by prying out with a small flat blade screwdriver. Be careful not to damage the body.
2. Install new seal by hand. Carefully work seal into groove. Make sure seal is fully installed with no damage.
3. Check to make sure the dry mate half is functional and all the safety features are working properly.



WARNING!

Make sure the Dry Mate is flushed clean of chemicals and other fluids before any rebuild or seal replacement.



BANJO CORPORATION

A Unit of IDEX Corporation
150 Banjo Drive
Crawfordsville, IN 47933 U.S.A.
Telephone: (765) 362-7367
Fax: (765) 362-0744
banjocorp.com



© Copyright 2016 Banjo Corporation. All Rights Reserved. | DryMatesManual_KK-82

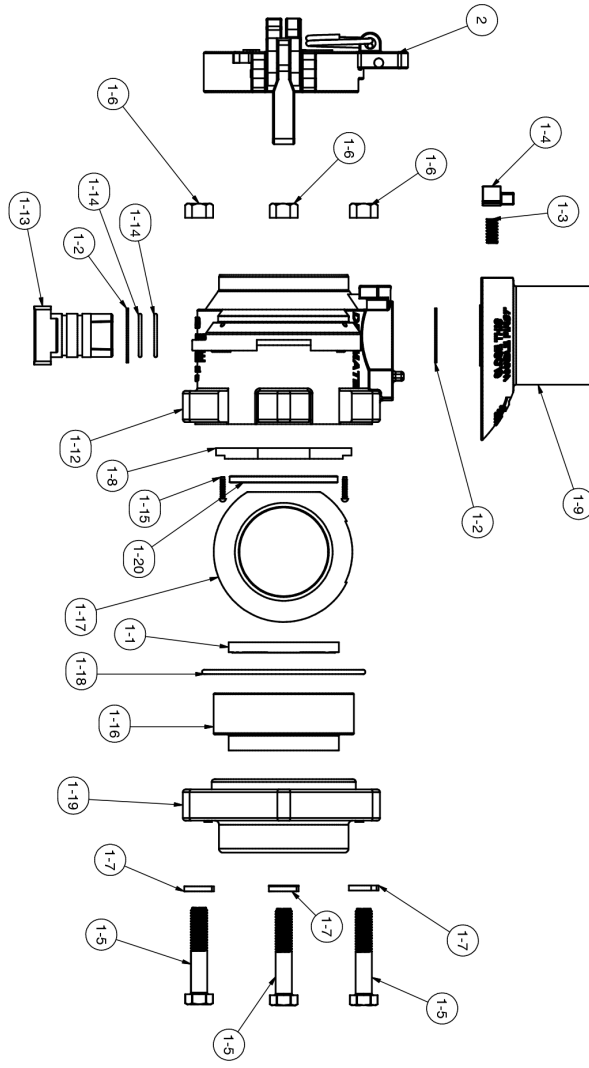
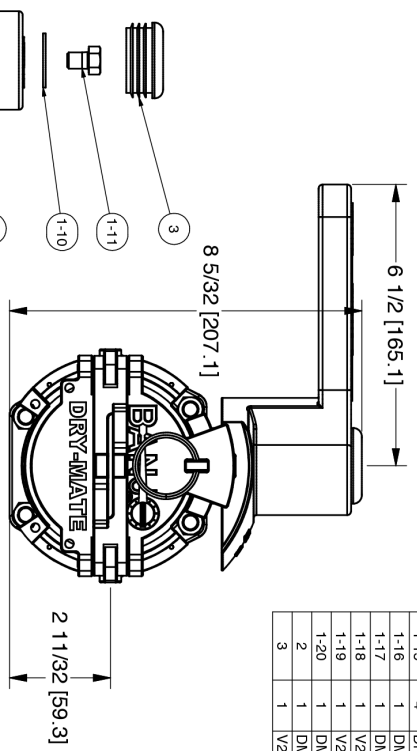
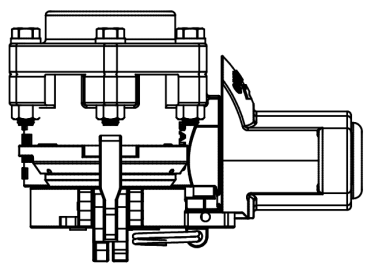
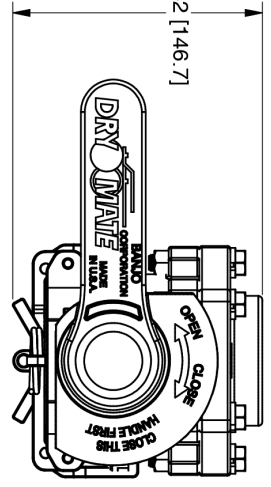
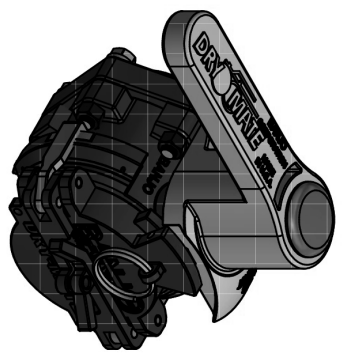

Parts List	
ITEM	DESCRIPTION
1	DM220AX 2" FP Poly Male Dry Mate Preest
1-1	V25258A 3" FP Ball Seat
1-2	V26080 VALVE STEM THRUST BEARING
1-3	DB20281 Dry Mate Handle Interlock Spring
1-4	DM25288M 2" FP Male DM Handle Interlock Button
1-5	V20010SS 3/8"-16 X 2" HHCS
1-6	V20019 3/8" HEX NUT
1-7	V20018 3/8" LOCKWASHER
1-8	DM25006 2" FP DM Clamp Rib
1-9	DM25153M 2" FP Male Poly DM Handle
1-10	V25121 3/8" Fender Washer
1-11	V26020 3/8" Handle Bolt
1-12	DM25254M 2" FP Male DM Body
1-13	VS25151C 3" Slubby Stem w/ O-Ring Grooves
1-14	A020V #20 O-RING
1-15	DP02050 #2 X 1/2" Type U Drive Screw
1-16	DM25256SP 2" FP Poly DM Body/EP Filler Machined
1-17	DM25255 2" FP DM Ball
1-18	V25264 CUSTOM BODY O-RING
1-19	V25256 2" Full Port Endplate
1-20	DM25258A 2" FP Poly DM Seat
2	DM220CAP 2" FP DM Dust CAP
3	V25502 3/4" Cap Plug

THIS DRAWING AND ALL INFORMATION CONTAINED THEREIN ARE THE PROPERTY OF BANJIO CORPORATION. UNLESS SPECIFICALLY NOTED, THIS DRAWING AND ITEMS SHOWN ON IT ARE SUBJECT TO CHANGE AT ANY TIME.



BANJIO CORPORATION
150 BANJIO DRIVE, CRAWFORDSVILLE, IN 47933
WEB SITE: WWW.BANJIOCORP.COM
E-MAIL: BANJIOSALES@BANCORP.COM

DESCRIPTION: 2" FP Poly Male Dry Mate
PART NUMBER: DM220A

NOTE: Please see banjio.com for more product drawings.

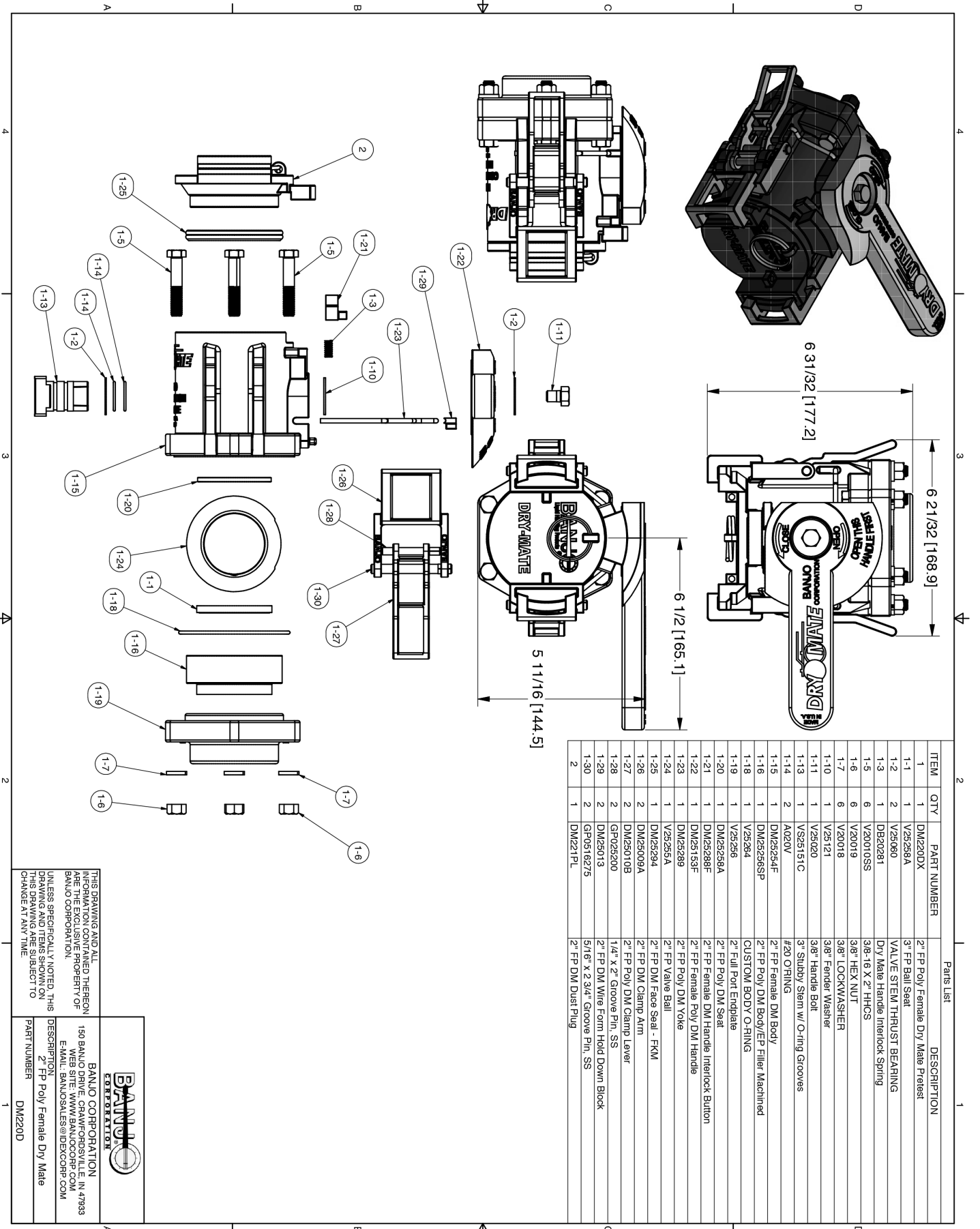

NOTE: Please see banjocorp.com for more product drawings.