

Parts List			
ITEM	QTY	PART NUMBER	DESCRIPTION
1	1	DM35254M	3" FP Male DM Body
2	2	V25060	VALVE STEM THRUST BEARING
3	1	DM35255	3" Full Port Dry Mate Ball
4	1	V30151C	3" Stem w/ O-ring Grooves
5	2	A020V	#20 O'RING
6	1	DM35258	3" FP DM Ball Seat
7	1	V35265	3" FP body O-ring FKM
8	1	DM35288M	3" FP DM Handle Button
9	1	DM35281	3" FP DM Button Spring
10	1	DM35153M	3" FP DM Male Handle
11	1	V25121	3/8" Fender Washer
12	1	V25020	3/8" Handle Bolt
13	1	V25502	3/4" Cap Plug
14	1	V35264	3" FP End Plate
15	1	V35258A	3" FP Ball Seat
16	6	V20010SS	3/8-16 X 2" HHCS
17	6	V20018	3/8" LOCKWASHER
18	6	V20019	3/8" HEX NUT
19	2	DM35006	3" FP DM Male Clamp Rib
20	4	DP02063	#2 x 5/8" Type U Drive Screw
21	1	DM300CAP	3" DM CAP

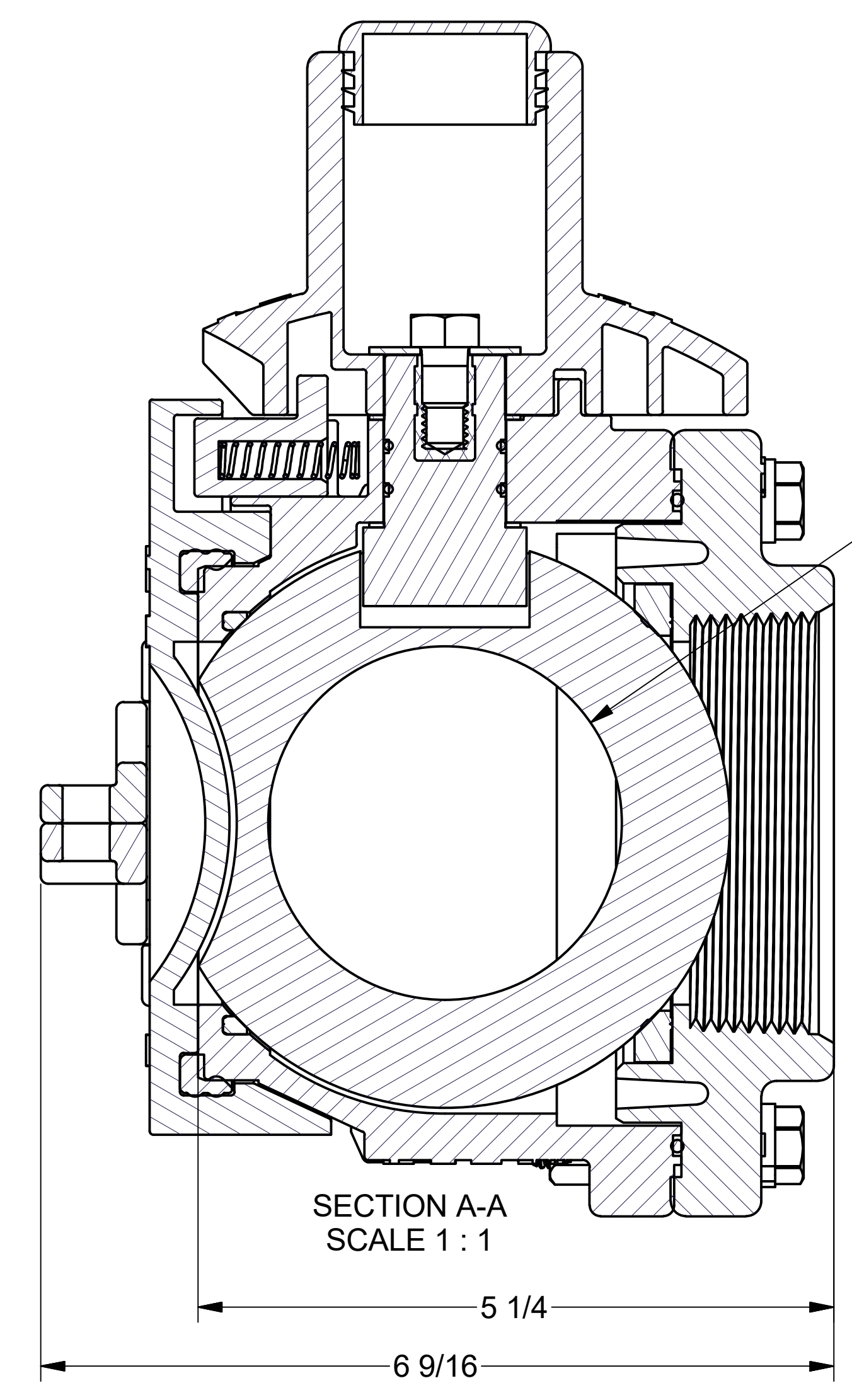
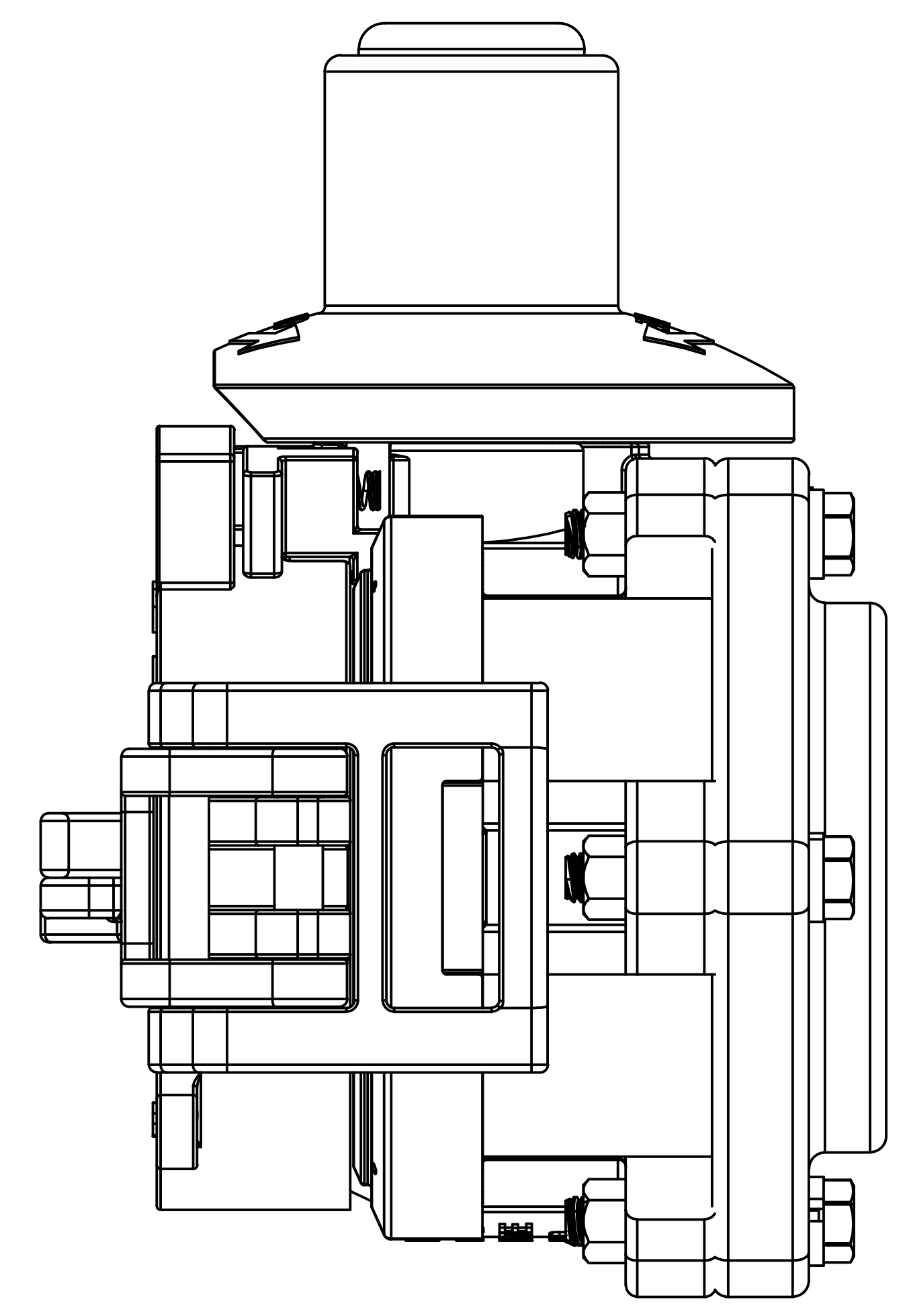

THIS DRAWING AND ALL INFORMATION CONTAINED THEREON ARE THE EXCLUSIVE PROPERTY OF BANJO CORPORATION. UNLESS SPECIFICALLY NOTED, THIS DRAWING AND ITEMS SHOWN ON THIS DRAWING ARE SUBJECT TO CHANGE AT ANY TIME.

**BANJO CORPORATION**

BANJO CORPORATION  
150 BANJO DRIVE, CRAWFORDSVILLE, IN 47933  
WEB SITE: WWW.BANJOCORP.COM  
E-MAIL: BANJOSALES@IDEXCORP.COM

DESCRIPTION  
**3" FP Male Dry Mate**

PART NUMBER  
**DM300AFP**