

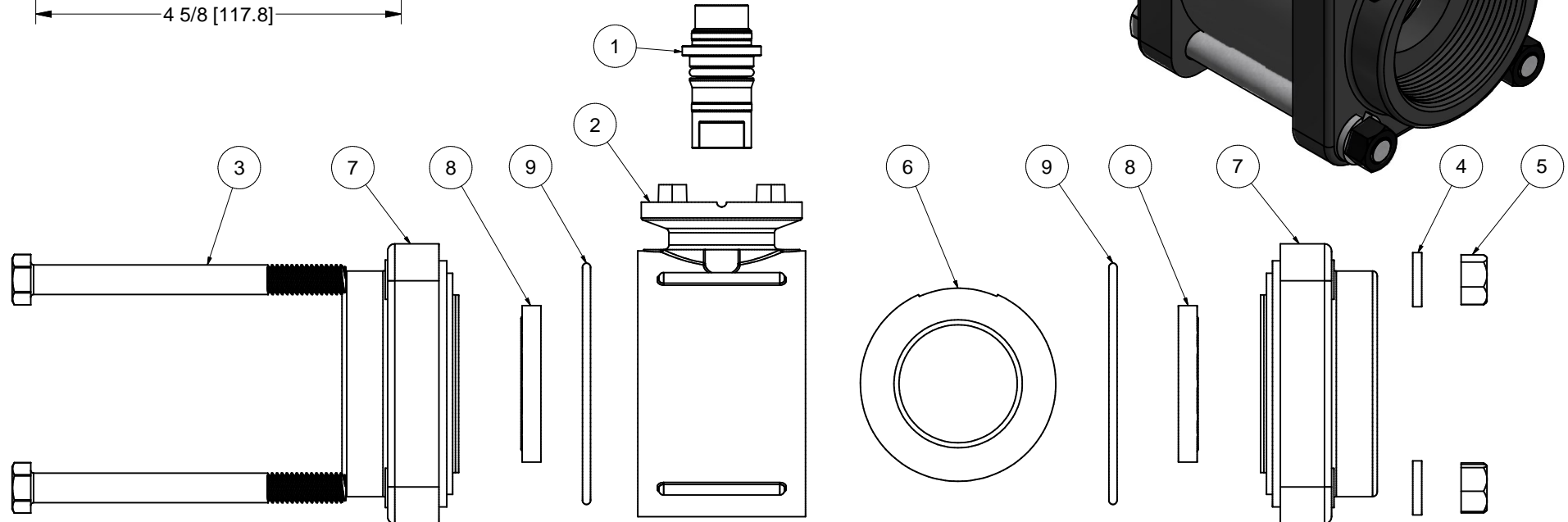

Parts List			
ITEM	QTY	PART NUMBER	DESCRIPTION
1	1	MEV10151	1" Top Load Stem Assy
2	1	MEV20254A	2" VE BODY
3	4	V20017	3/8-16 X 4" HHCS
4	4	V20018	3/8" LOCKWASHER
5	4	V20019	3/8" HEX NUT
6	1	VE20255SSH	2" VE SS Hollow Ball
7	2	VE20256A	2" ELECTRIC VALVE END PLATE
8	2	VE20258A	2" VE Seat TFM
9	2	VE20264E	2-150 O'RING, EPDM

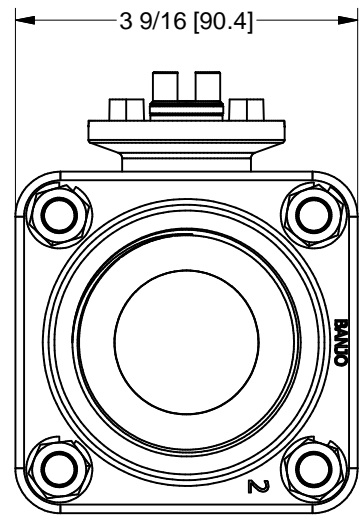
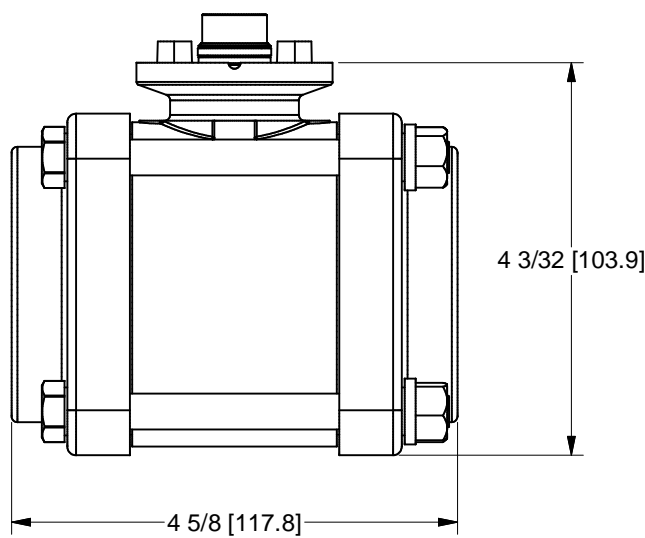
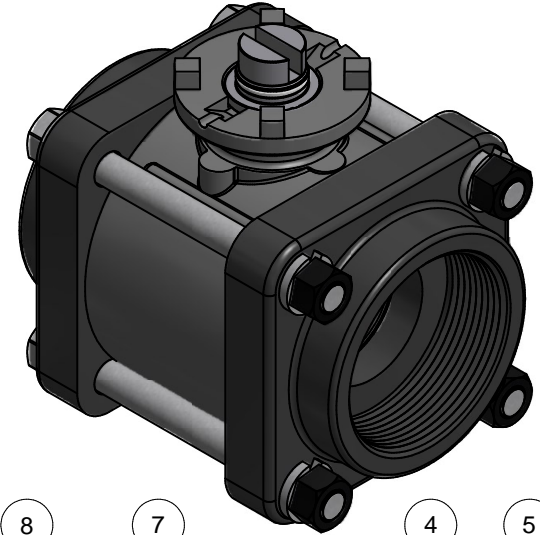

Assembly Specs:
 Body Bolt Tightening Torque: 75 in-lb
 Max Stem Turning Torque: 75 in-lb

THIS DRAWING AND ALL INFORMATION CONTAINED THEREON ARE THE EXCLUSIVE PROPERTY OF BANJO CORPORATION. UNLESS SPECIFICALLY NOTED, THIS DRAWING AND ITEMS SHOWN ON THIS DRAWING ARE SUBJECT TO CHANGE AT ANY TIME.	
	BANJO CORPORATION 150 BANJO DRIVE, CRAWFORDSVILLE, IN 47933 WEB SITE: WWW.BANJOCORP.COM E-MAIL: SALES1@BANJOCORP.COM
DESCRIPTION	2" VALVE ONLY
PART NUMBER	EV200XR1