

PARTS LIST			
ITEM	QTY	PART NUMBER	DESCRIPTION
1	2	12901	5/16" FLAT WASHER
2	2	17019	5/16-18 X 3/4" HHCS
3	2	V10118	5/16" LOCKWASHER
4	2	V10119	5/16" HEX NUT
5	6	V20018	3/8" LOCKWASHER
6	6	V20019	3/8" HEX NUT
7	1	V25160	STEM BUSHING
8	1	V25163	#214 FKM O'RING
9	4	V35017	3/8"-16 x 6" HHCS, 18-8SS
10	2	V35018	3/8"-16 x 6.5" HHCS, 18-8SS
11	1	V35254	3" FP VALVE BODY
12	1	V35255ASS	3" FP SS HOLLOW BALL
13	2	V35264	3" NPT FP ENDPLATE, MACHINED
14	2	V35265	3" FP BODY O-RING FKM
15	1	VE30022	1" EXTERNAL SNAP RING - SS
16	1	VE30121	1" 18-8SS SHIM
17	1	VE30151SS	ELECTRIC VALVE STEM SS
18	1	VE35188	3" FP EV ACTUATOR LARGE BRACKET
19	1	VE35189	3" FP ACTUATOR SMALL BRACKET
20	2	VE35258B	3" FP BALL SEAT
21	1	VL1016	200 PSI DECAL (N/S)

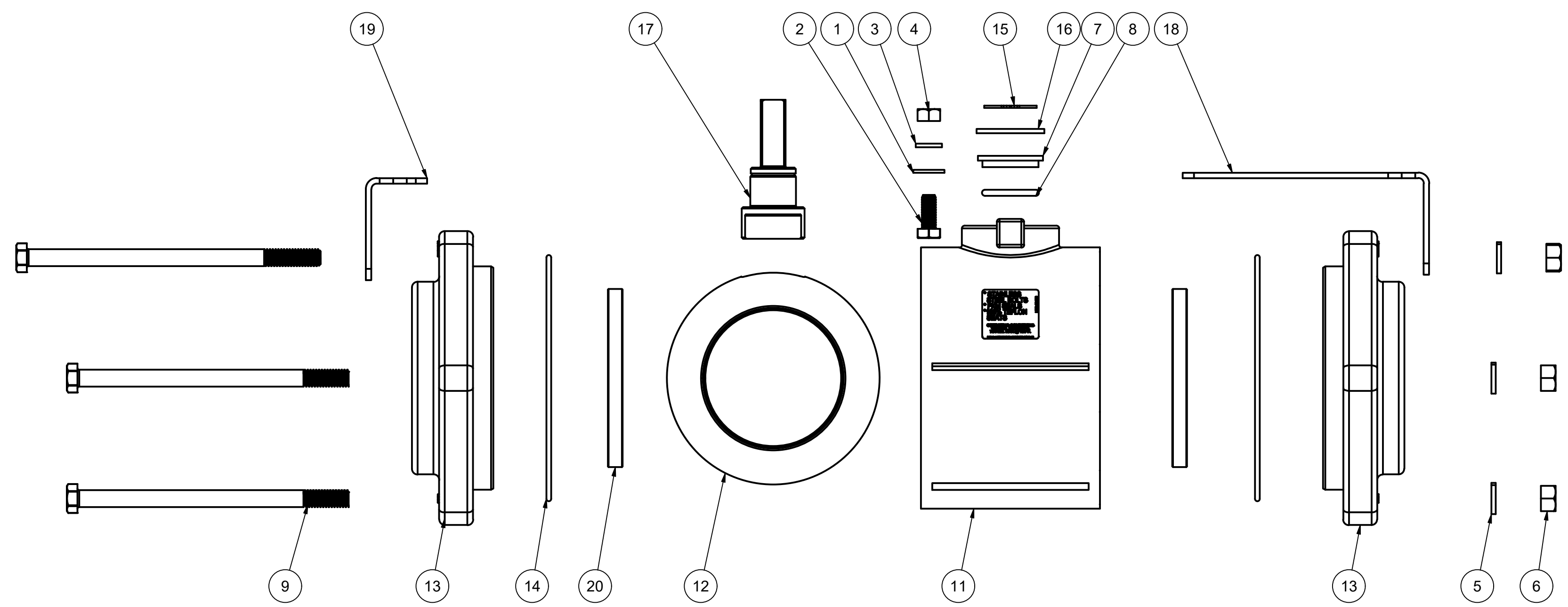
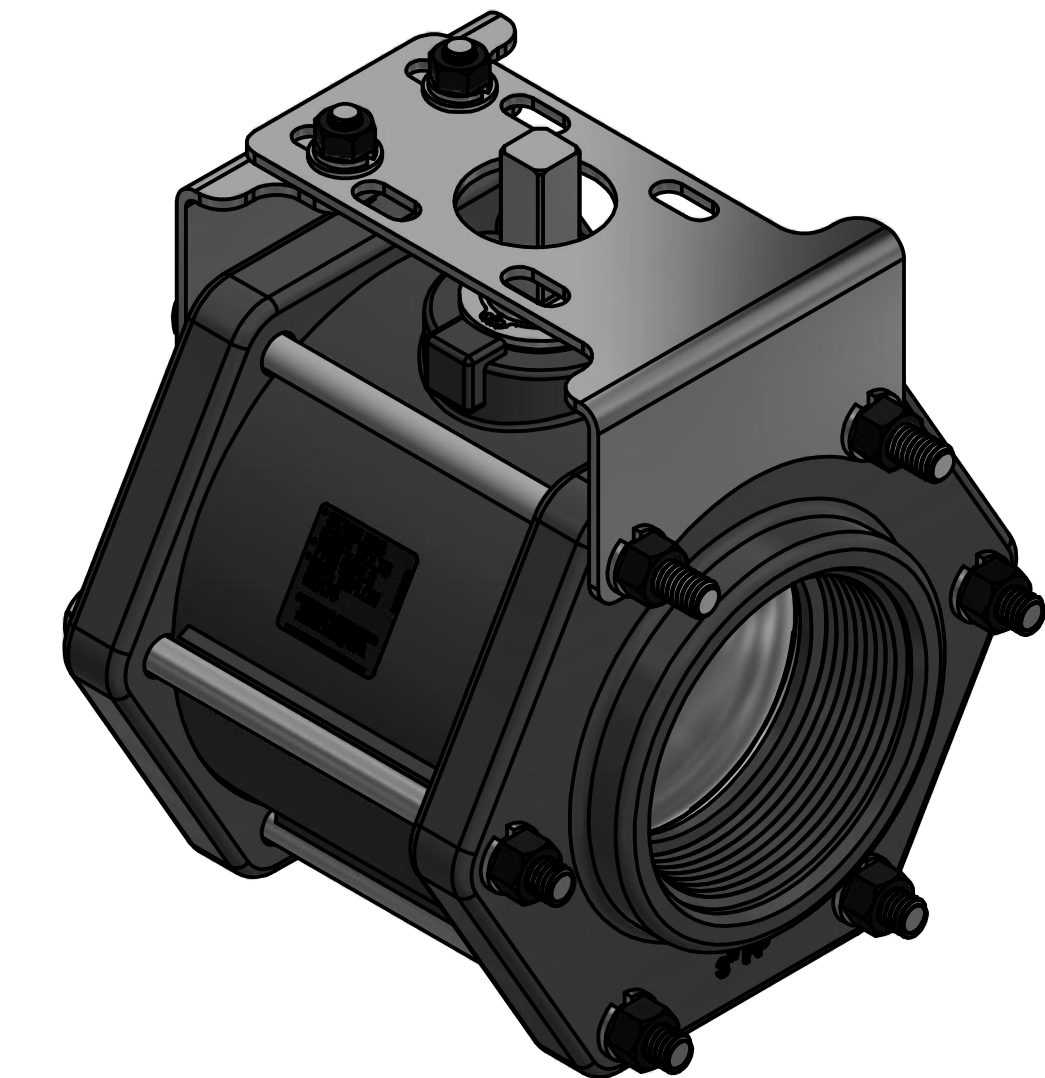

THIS DRAWING AND ALL INFORMATION CONTAINED THEREON ARE THE EXCLUSIVE PROPERTY OF BANJO CORPORATION.

UNLESS SPECIFICALLY NOTED, THIS DRAWING AND ITEMS SHOWN ON THIS DRAWING ARE SUBJECT TO CHANGE AT ANY TIME.

BANJO CORPORATION
 150 BANJO DRIVE, CRAWFORDSVILLE, IN 47933
 WEB SITE: WWW.BANJO.CORP.COM
 E-MAIL: BANJOSALES@IDEXCORP.COM

DESCRIPTION
3" FP ELECTRIC VALVE ONLY

PART NUMBER
EV300XR1A