

Parts List				
ITEM	QTY	PART NUMBER	DESCRIPTION	
11	1	A161	2-161 O-RING, EPDM	
8	1	A162	2-162 O-RING EPDM	
6	1	F10E	AS568A -121 O-RING, EPDM, BLACK	
1	1	MEV10101B	ELECTRIC VALVE ACTUATOR BOTTOM, SMALL MOTOR	
2	1	MEV10102D	ELECTRIC VALVE ACTUATOR TOP, SMALL MOTOR, 1/4" CABLE SEAL	
2-1	1	MEV10102DX	Electric Valve Actuator Top, Small Motor, 1/4" Cable Seal	
2-2	1	VEL1004	VE "OPEN" Sticker	
2-3	1	VEL1005	VE "CLOSED" Sticker	
10	1	MVE002	HEYCO THREADED BUSHING	
12	1	MVE007	3MMX5MM FKM O-RING	
4	1	MVE105	VE MOTOR GASKET W/ 3/8" HOLE, EPDM	
5	1	VE107B	EV INDICATOR	
7	1	VE109E	VE BOX SHAFT SEAL - EPDM	
3	10	VE15220	#6x3/4"18-8SS HWH SMS	
9	1	VE49844	1" STANDARD VE MOTOR - 4 WIRE SHORT SHAFT	
13	1	VEL1007	EV ON/OFF STICKER	
14	1	VEL1022	INTERNAL FUSE DECAL	
15	1	VEL1023	INDICATOR DECAL (N/S)	

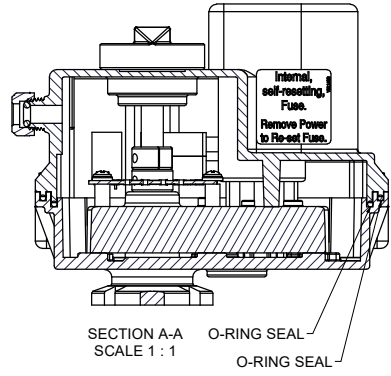

THIS DRAWING AND ALL INFORMATION CONTAINED THEREON ARE THE EXCLUSIVE PROPERTY OF BANJO CORPORATION.

UNLESS SPECIFICALLY NOTED, THIS DRAWING AND ITEMS SHOWN ON THIS DRAWING ARE SUBJECT TO CHANGE AT ANY TIME.

BANJO CORPORATION

BANJO CORPORATION
150 BANJO DRIVE, CRAWFORDSVILLE, IN 47933
WEB SITE: WWW.BANJO.CORP.COM
E-MAIL: BANJO.SALES@IDEXCORP.COM

DESCRIPTION
3/4 SEC, 4 WIRE, EV ACTUATOR ASSY

PART NUMBER
EV3304