

Parts List			
ITEM	QTY	PART NUMBER	DESCRIPTION
1	1	AQ206V	#206 QUAD RING, FKM
2	1	EVP20151A	EVX VALVE SS STEM 1-2"SP BOLTED
3	1	MEVX10254A	1" FP EVX 2-WAY BOLTED BODY, MACH
4	4	V10117	5/16 - 18 X 3 1/2" HHCS
5	4	V10118	5/16" LOCKWASHER
6	4	V10119	5/16" HEX NUT
7	1	VE10155SSH	1" VE SS Hollow Ball
8	2	VE10256A	1 1/4" VE ENDPLATE
9	2	VE10258A	1" VE Seat TFM
10	2	VE10264	#139 O-RING, FKM

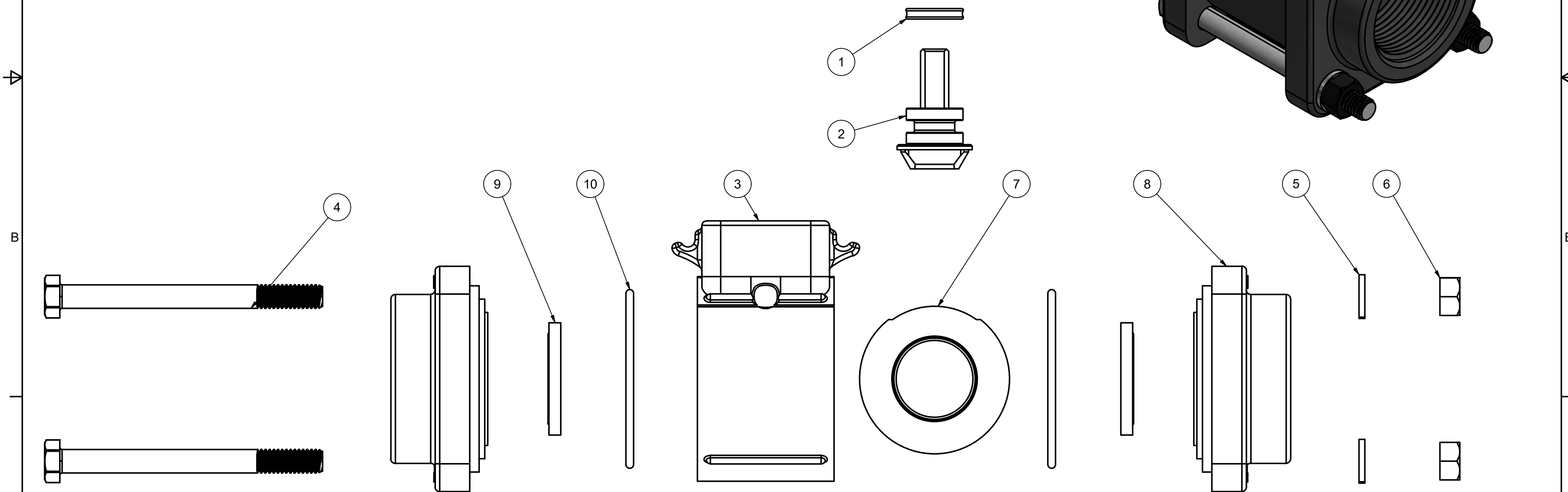
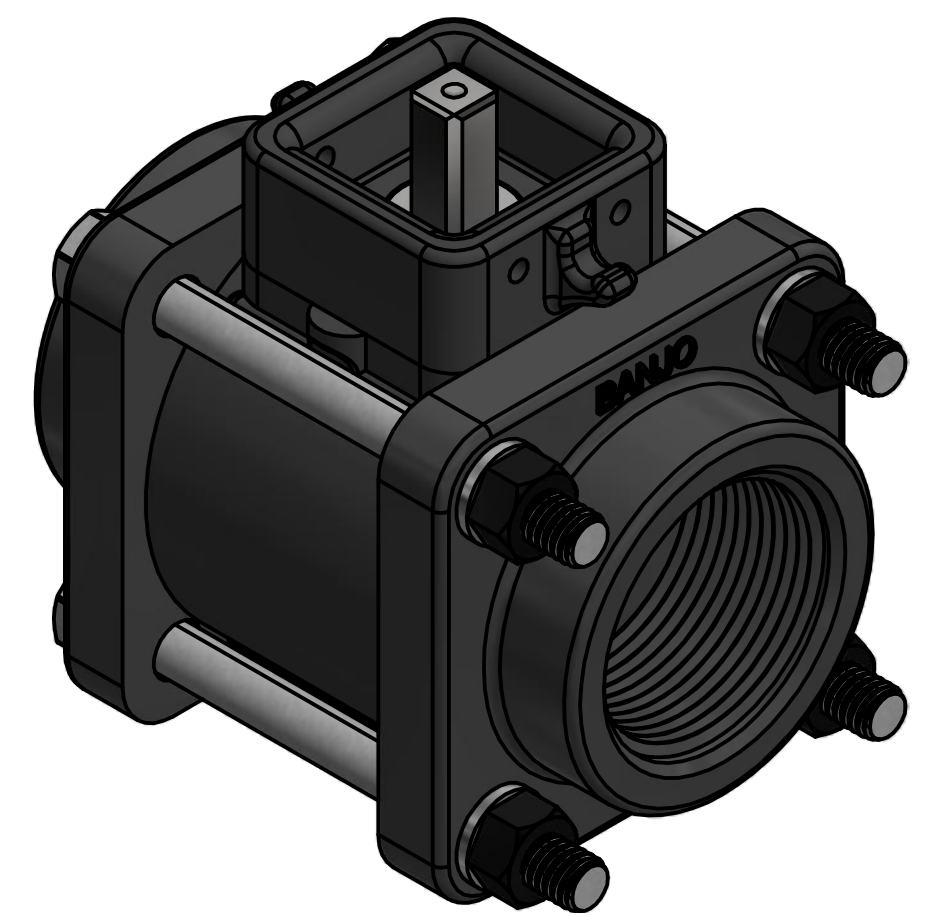

Assembly specs:
 Body Bolt Tightening Torque: 75 in-lb.
 Max Stem Turning Torque: 50 in-lb.

THIS DRAWING AND ALL INFORMATION CONTAINED THEREON ARE THE EXCLUSIVE PROPERTY OF BANJO CORPORATION.
 UNLESS SPECIFICALLY NOTED, THIS DRAWING AND ITEMS SHOWN ON THIS DRAWING ARE SUBJECT TO CHANGE AT ANY TIME.

BANJO CORPORATION
 150 BANJO DRIVE, CRAWFORDSVILLE, IN 47933
 WEB SITE: WWW.BANJOCORP.COM
 E-MAIL: BANJOSALES@IDEXCORP.COM

DESCRIPTION
 EVX 1 1/4" NPT 2 WAY BOLTED VALVE ONLY

PART NUMBER
 EVX121X