

Parts List			
ITEM	QTY	PART NUMBER	DESCRIPTION
1	1	AQ206V	#206 QUAD RING, FKM
2	1	EVP20151A	EVX VALVE SS STEM 1-2"SP BOLTED
3	1	MEVX20254A	2" SP EVX BOLTED BODY
4	4	V20017	3/8-16 X 4" HHCS
5	4	V20018	3/8" LOCKWASHER
6	4	V20019	3/8" HEX NUT
7	1	VE20255SSH	2" VE SS Hollow Ball
8	2	VE20257A	1-1/2" END PLATE
9	2	VE20258A	2" VE Seat TFM
10	2	VE20264	2-150 O'RING, FKM

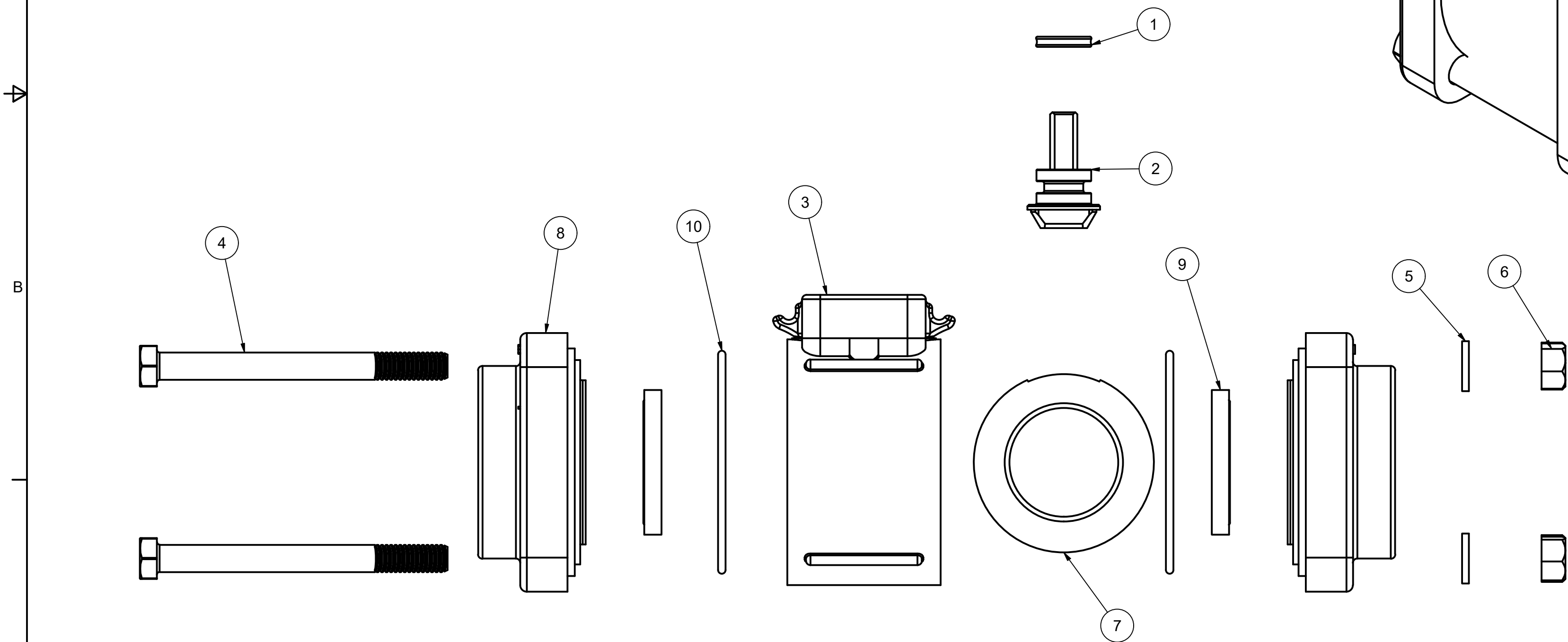
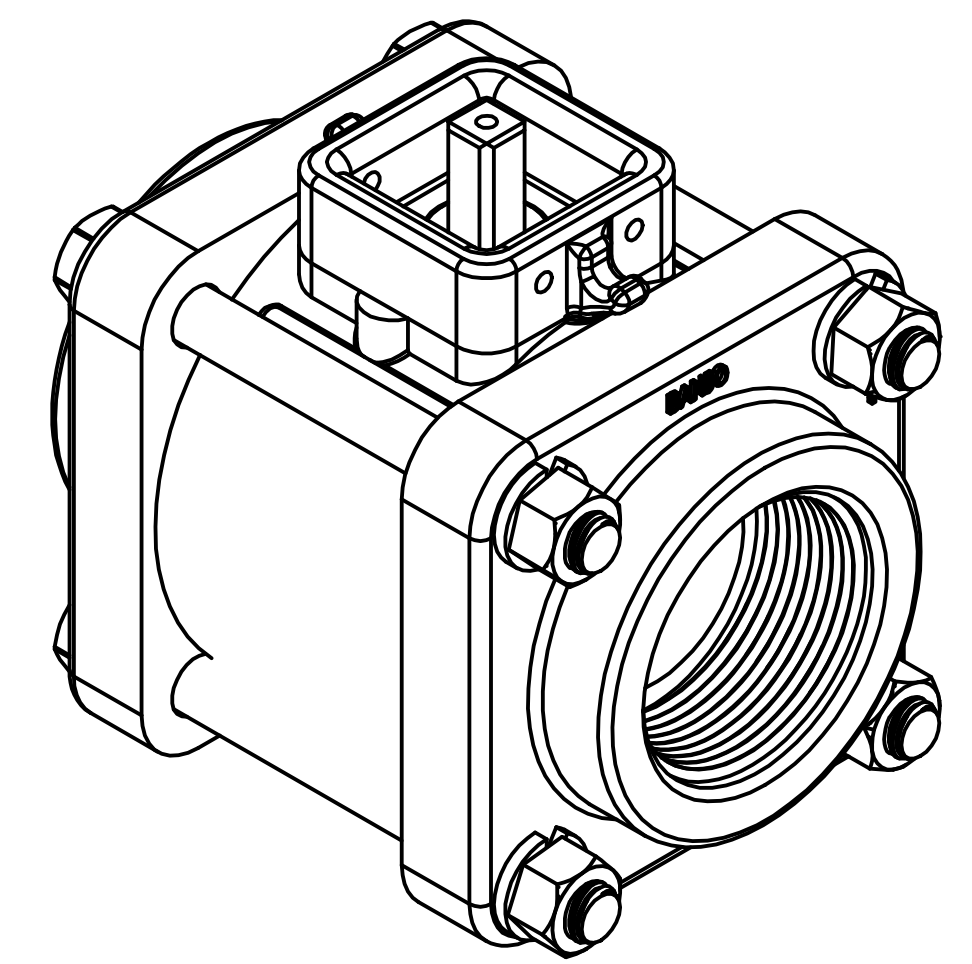

THIS DRAWING AND ALL INFORMATION CONTAINED THEREON ARE THE EXCLUSIVE PROPERTY OF BANJO CORPORATION.

UNLESS SPECIFICALLY NOTED, THIS DRAWING AND ITEMS SHOWN ON THIS DRAWING ARE SUBJECT TO CHANGE AT ANY TIME.

**BANJO CORPORATION**

150 BANJO DRIVE, CRAWFORDSVILLE, IN 47933  
 WEB SITE: WWW.BANJOCORP.COM  
 E-MAIL: BANJOSALES@IDEXCORP.COM

DESCRIPTION  
 EVX 1 1/2" NPT 2 WAY BOLTED VALVE ONLY

PART NUMBER  
 EVX151X