

Parts List			
ITEM	QTY	PART NUMBER	DESCRIPTION
1	1	AQ206V	#206 QUAD RING, FKM
2	1	EVP20151A	EVX VALVE SS STEM 1-2"SP BOLTED
3	1	MEVX20354AB	2" BL VE BODY
4	4	V20017	3/8-16 X 4" HHCS
5	4	V20018	3/8" LOCKWASHER
6	4	V20019	3/8" HEX NUT
7	2	VE20256A	2" ELECTRIC VALVE END PLATE
8	2	VE20258A	2" VE Seat TFM
9	2	VE20264	2-150 O'RING, FKM
10	1	VE20355	2" VE 3-Way SS Ball

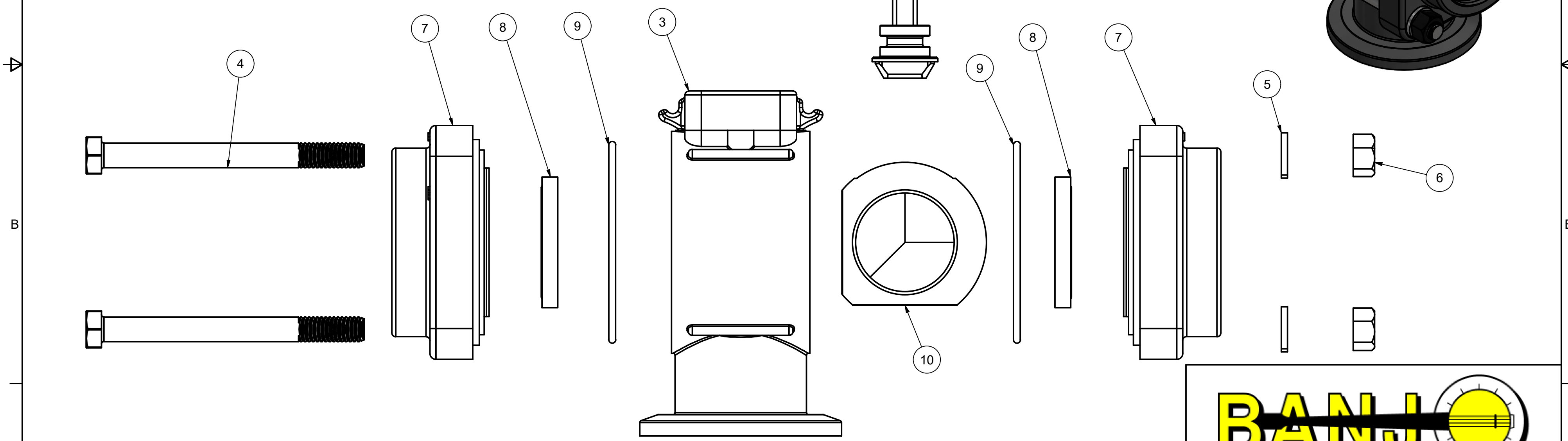
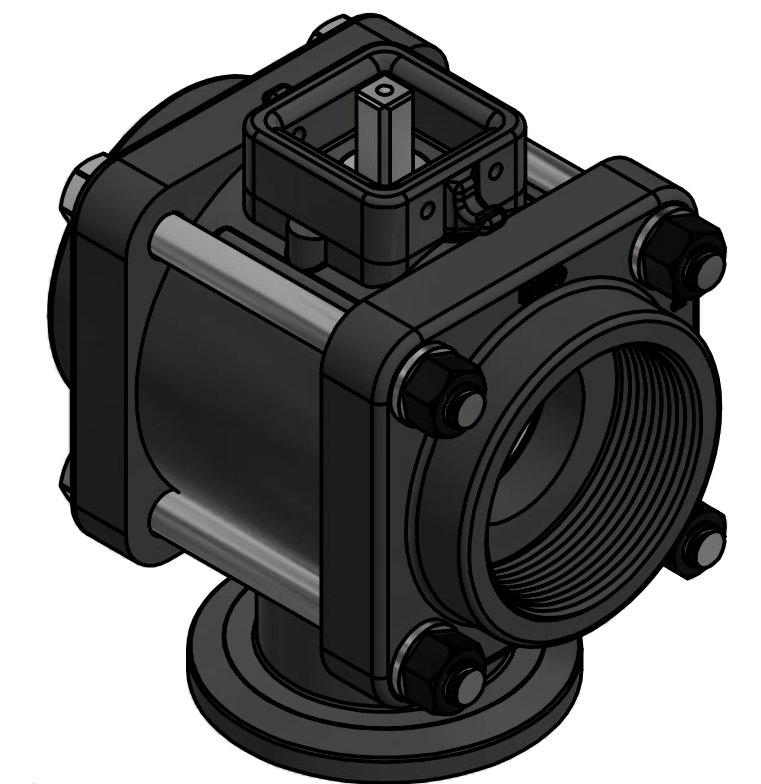

ASSEMBLY SPECS:
BODY BOLT TIGHTENING TORQUE: 75 IN-LB
MAX STEM TURNING TORQUE: 75 IN-LB

THIS DRAWING AND ALL INFORMATION CONTAINED THEREON ARE THE EXCLUSIVE PROPERTY OF BANJO CORPORATION.

UNLESS SPECIFICALLY NOTED, THIS DRAWING AND ITEMS SHOWN ON THIS DRAWING ARE SUBJECT TO CHANGE AT ANY TIME.

BANJO CORPORATION
 150 BANJO DRIVE, CRAWFORDSVILLE, IN 47933
 WEB SITE: WWW.BANJOCORP.COM
 E-MAIL: BANJOSALES@IDEXCORP.COM

DESCRIPTION	EVX 2" NPT SP BL VALVE ONLY
PART NUMBER	EVX200BLX