

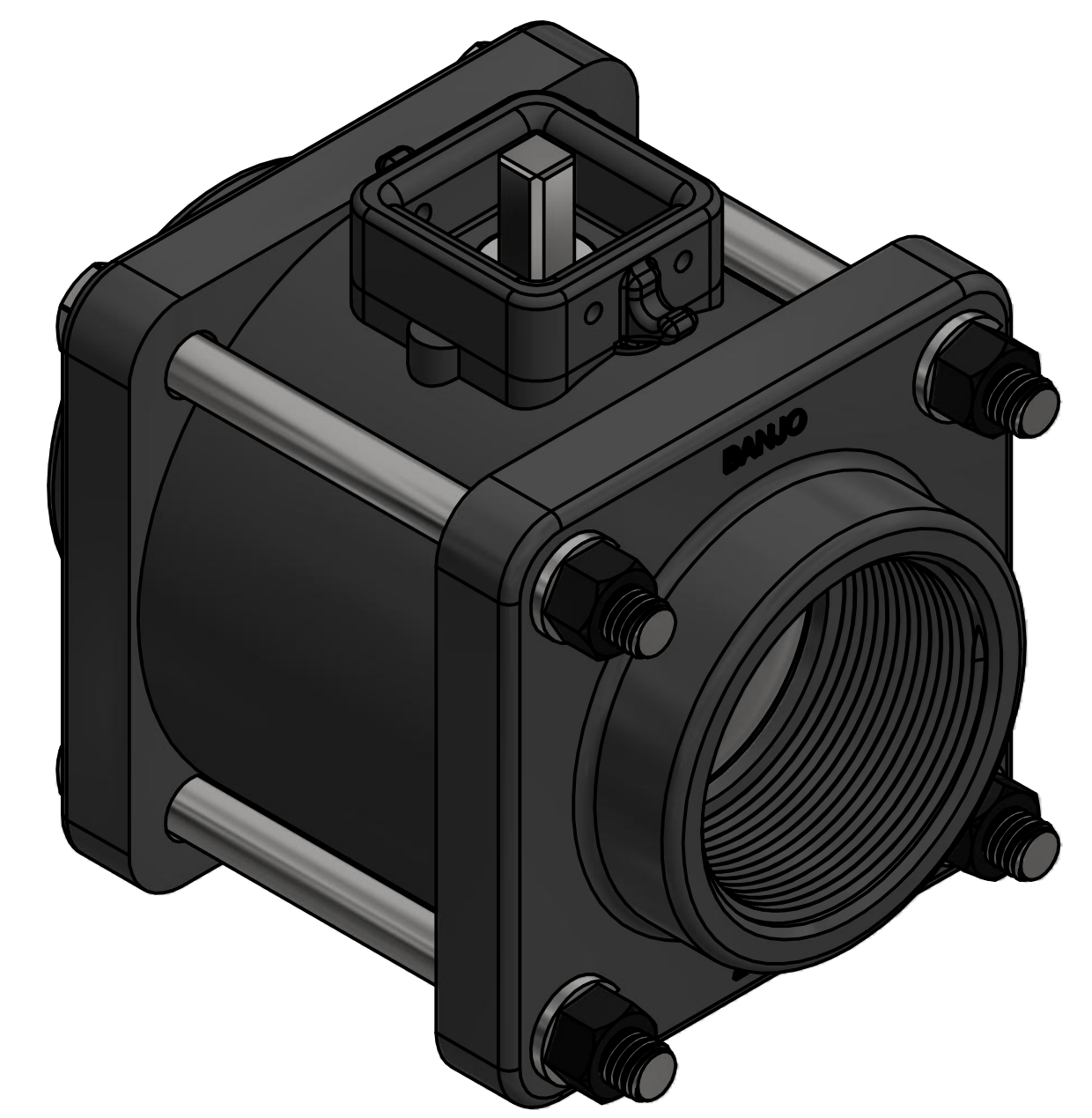

Parts List			
ITEM	QTY	PART NUMBER	DESCRIPTION
1	1	AQ206V	#206 QUAD RING, FKM
2	1	EVP25151	EVX VALVE SS STEM 2"FP BOLTED
3	1	MEVX25254A	2" FP EVX 2 WAY BOLTED BODY
4	4	V20018	3/8" LOCKWASHER
5	4	V20019	3/8" HEX NUT
6	4	V25017	3/8-16 X 4 1/2" HHCS
7	2	V25264	O-RING, ID: 3.575", CS: 0.103, FKM
8	1	VE25255SSH	2" FP VE SS Hollow Ball
9	2	VE25258A	2" FP VE Seat TFM
10	2	VE25356A	2" FP VE 4 Bolt ENDPLATE



**ASSEMBLY SPECS:**  
 BODY BOLT TIGHTENING TORQUE: 75 IN-LBS  
 MAX STEM TURNING TORQUE: 75 IN-LBS

THIS DRAWING AND ALL INFORMATION CONTAINED THEREON ARE THE EXCLUSIVE PROPERTY OF BANJO CORPORATION.  
 UNLESS SPECIFICALLY NOTED, THIS DRAWING AND ITEMS SHOWN ON THIS DRAWING ARE SUBJECT TO CHANGE AT ANY TIME.



BANJO CORPORATION  
 150 BANJO DRIVE, CRAWFORDSVILLE, IN 47933  
 WEB SITE: WWW.BANJO.CORP.COM  
 E-MAIL: BANJOSALES@IDEXCORP.COM

DESCRIPTION  
 EVX 2" NPT FP 2 WAY BOLTED VALVE ONLY

PART NUMBER  
 EVX221X