

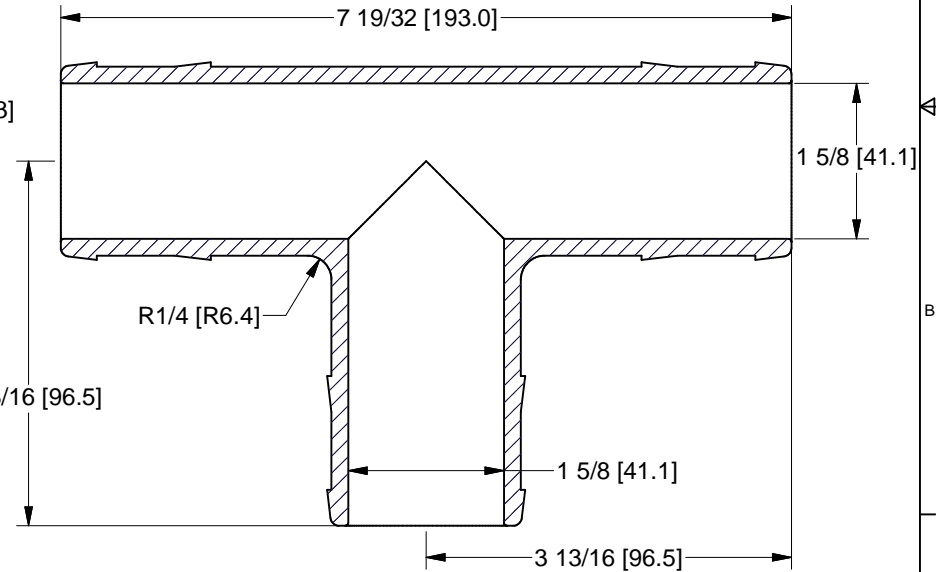

Text raised 0.03" as shown.
 "HBT200" raised 0.03 on opposite side.

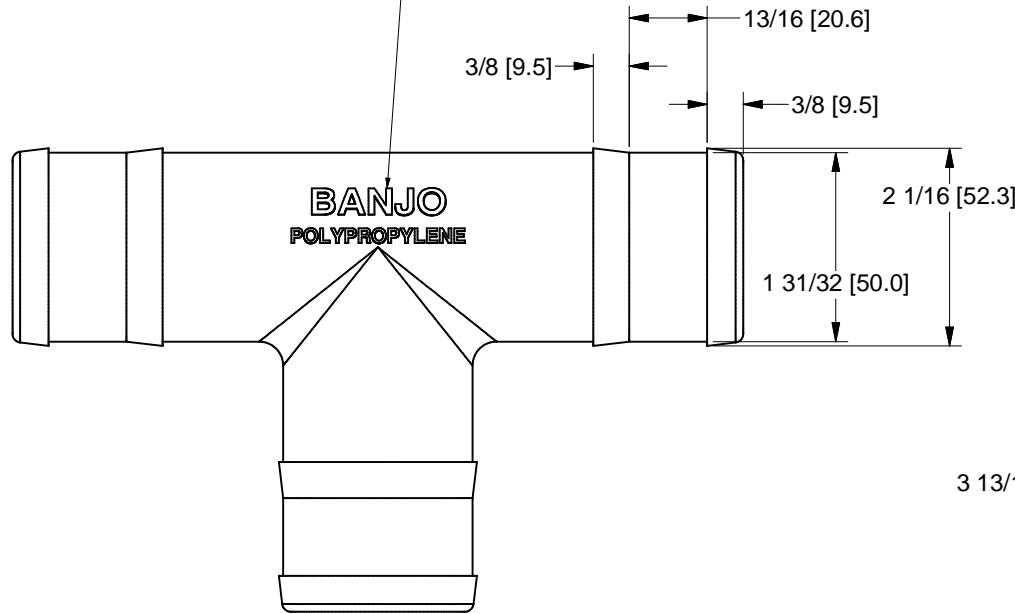

SECTION B-B
 SCALE 1 : 1

| | | | |
|--|--------------------|--|---------------|
| TOLERANCE UNLESS OTHERWISE SPECIFIED: DECIMALS 0.00 \pm 0.010 DECIMALS 0.000 \pm 0.005 FRACTIONS 1/8 \pm 1/32 ANGLES \pm 45' BREAK ALL SHOWN CORNERS W/ 1/32 R UNLESS OTHERWISE SPECIFIED | |  BANJO CORPORATION 150 BANJO DRIVE, CRAWFORDSVILLE, IN 47933 | |
| DRAWN Aaron | DATE 4/21/2010 | | |
| SIZE C | DWG. TYPE SALES | DWG. NO. HBT200 | REV HBT200 |
| SCALE | | SHEET 3 OF 3 | |