

***NOTE:
ADDITIONAL CLEARANCE REQ'D
FOR SCREEN REMOVAL: 5 1/4"**

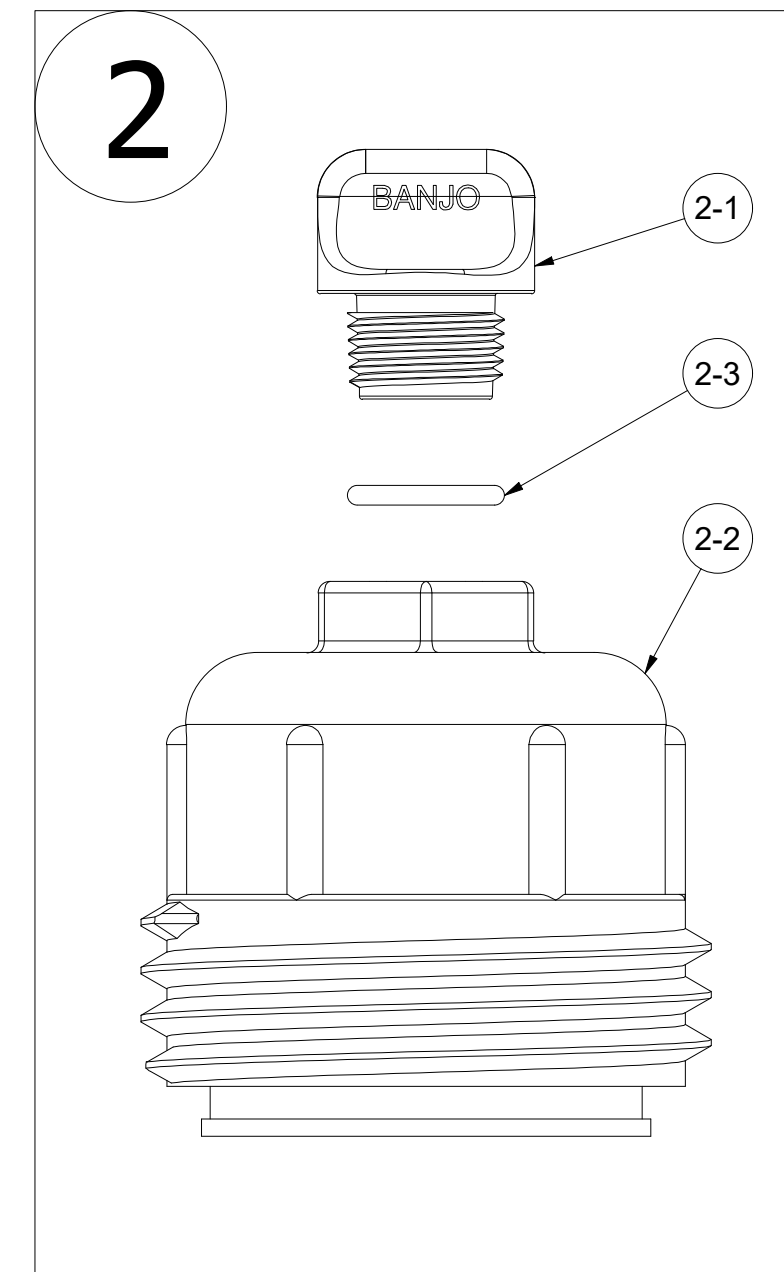

Parts List			
ITEM	QTY	PART NUMBER	DESCRIPTION
1	1	LS100-B	1" LINE STRAINER BODY
2	1	LS100-C1	LINE STRAINER CAP ASSY
2-1	1	12777	1/2" DRAIN PLUG
2-2	1	LS100XC1	1" LINE STRAINER CAP
2-3	1	UV15163	#114 O'RING, EPDM
3	1	LS100-G	AS568A -228 O-RING, EPDM, BLACK
4	1	LST1200D	200 PSI DECAL

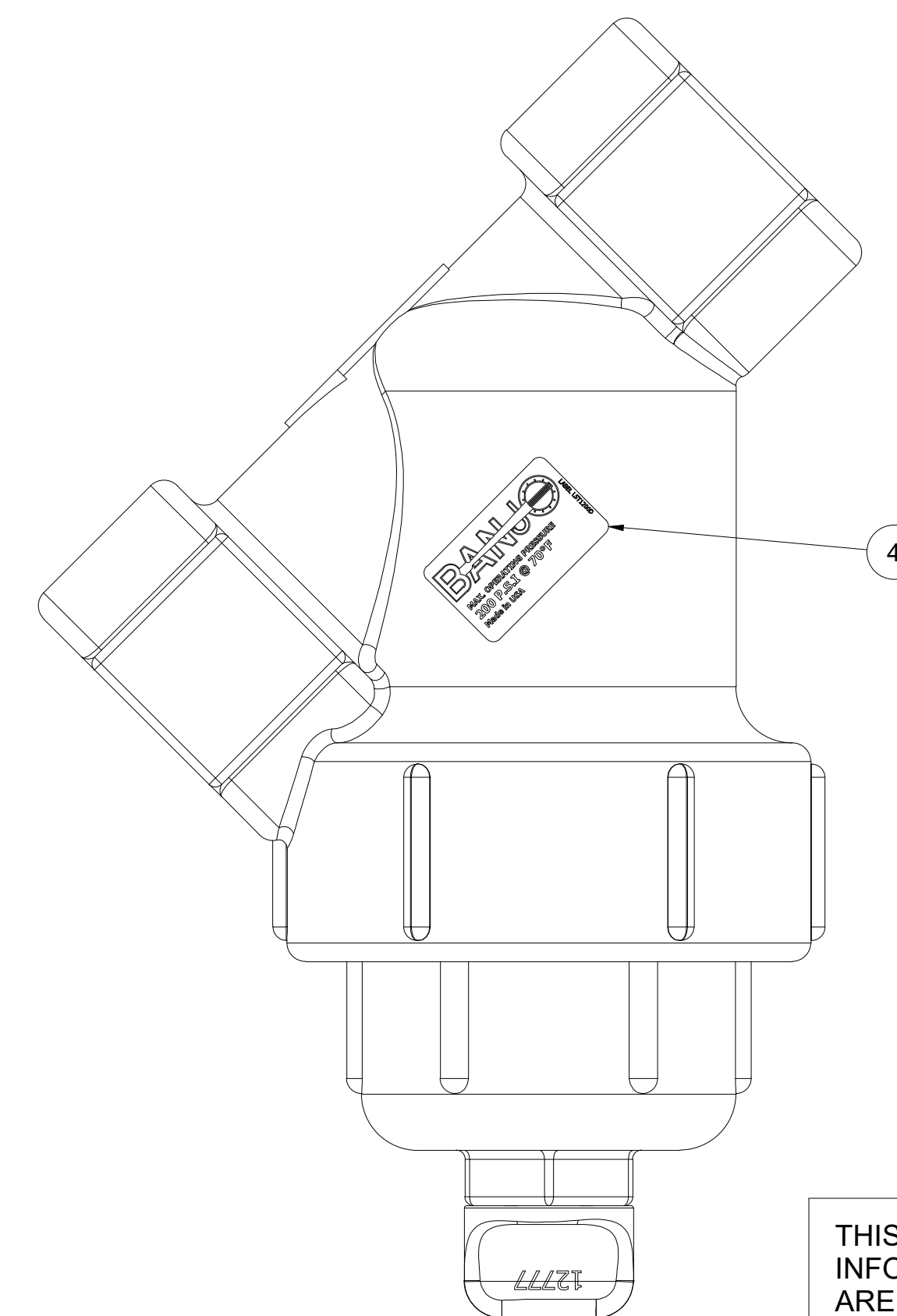
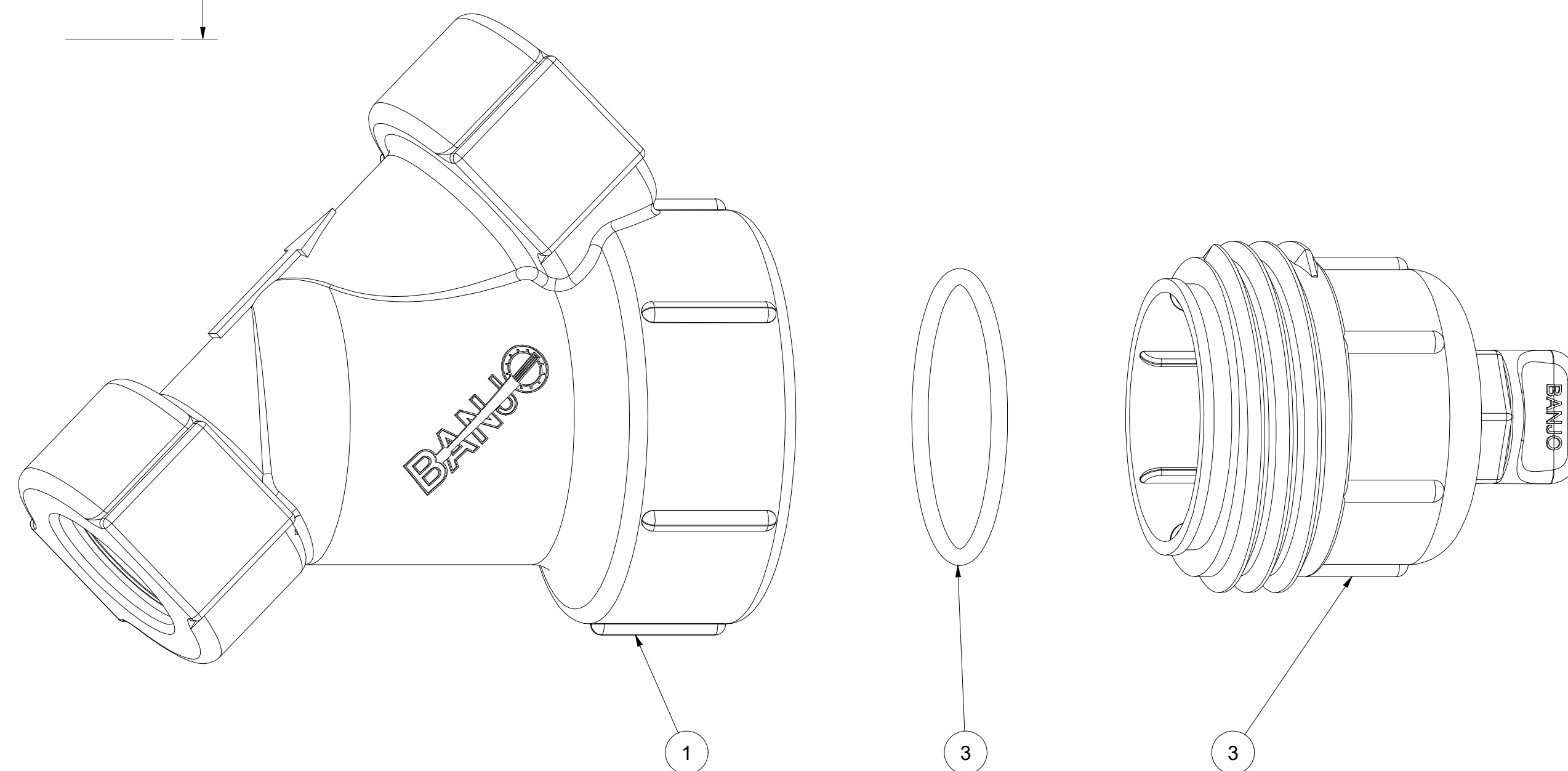

THIS DRAWING AND ALL INFORMATION CONTAINED THEREON ARE THE EXCLUSIVE PROPERTY OF BANJO CORPORATION.

UNLESS SPECIFICALLY NOTED, THIS DRAWING AND ITEMS SHOWN ON THIS DRAWING ARE SUBJECT TO CHANGE AT ANY TIME.



BANJO CORPORATION
150 BANJO DRIVE, CRAWFORDSVILLE, IN 47933
WEB SITE: WWW.BANJO.CORP.COM
E-MAIL: BANJOSALES@DEXCORP.COM

DESCRIPTION
1" LINE STR BODY & CAP W/DRAIN

PART NUMBER
LS100B-C1