

PARTS LIST			
ITEM	QTY	PART NUMBER	DESCRIPTION
1	1	LS150-B	1 1/2" LINE STRAINER BODY
2	1	LS150-G	AS568A -339 O-RING, EPDM, BLACK
3	1	LS150XC	1 1/2" & 2" LS CAP
4	1	LS212	2" LS SCREEN - 12 MESH
5	1	LSQ200-PL	1" NPT LINE STRAINER PLUG
6	1	LSQ200-R	AS568A -123 O-RING, EPDM, BLACK
7	1	LST100-D	LINE STRAINER DECAL

*NOTE:
ADDITIONAL CLEARANCE REQ'D
FOR SCREEN REMOVAL: 7"

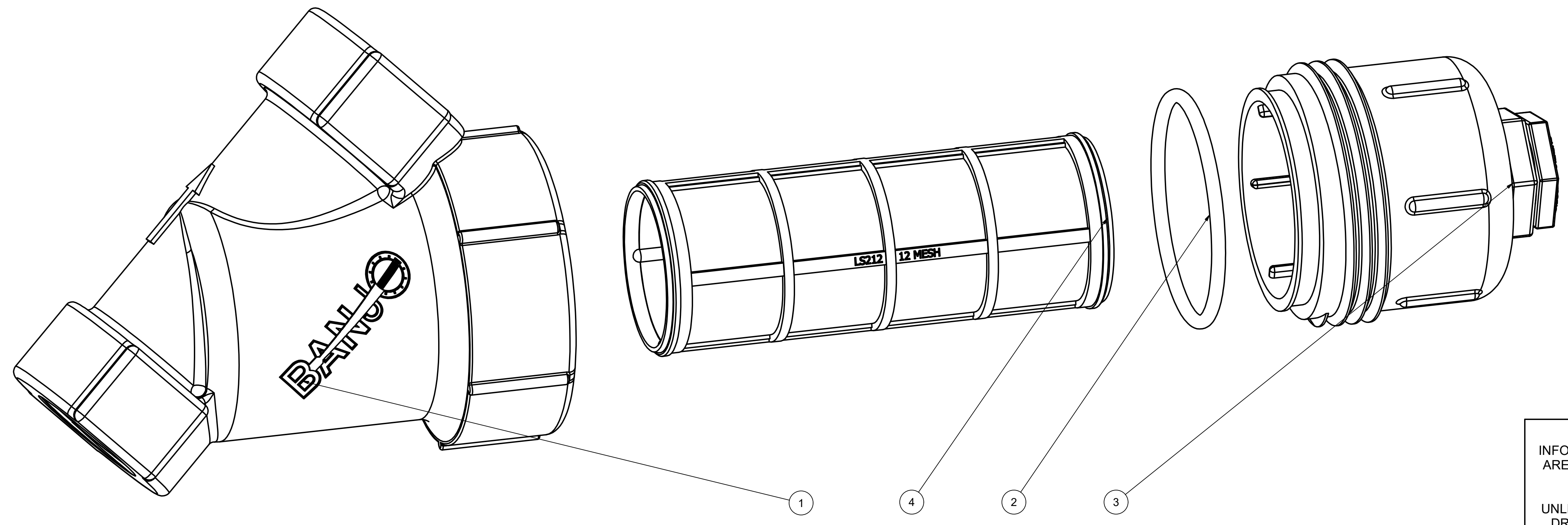

THIS DRAWING AND ALL
INFORMATION CONTAINED THEREON
ARE THE EXCLUSIVE PROPERTY OF
BANJO CORPORATION.

UNLESS SPECIFICALLY NOTED, THIS
DRAWING AND ITEMS SHOWN ON
THIS DRAWING ARE SUBJECT TO
CHANGE AT ANY TIME.

BANJO
CORPORATION

BANJO CORPORATION
150 BANJO DRIVE, CRAWFORDSVILLE, IN 47933
WEB SITE: WWW.BANJO.CORP.COM
E-MAIL: BANJOSALES@IDEXCORP.COM

DESCRIPTION
1-1/2" LINE STRAINER 12 MESH

PART NUMBER
LS150-12