

Parts List			
ITEM	QTY	PART NUMBER	DESCRIPTION
1	1	LS150-B	1 1/2" LINE STRAINER BODY
2	1	LS150-G	AS568A -339 O-RING, EPDM, BLACK
3	1	LS150XC	1 1/2" & 2" LS CAP
4	1	LS2120	2" LS SCREEN - 120 MESH
5	1	LSQ200-PL	1" NPT LINE STRAINER PLUG
6	1	LSQ200-R	AS568A -123 O-RING, EPDM, BLACK

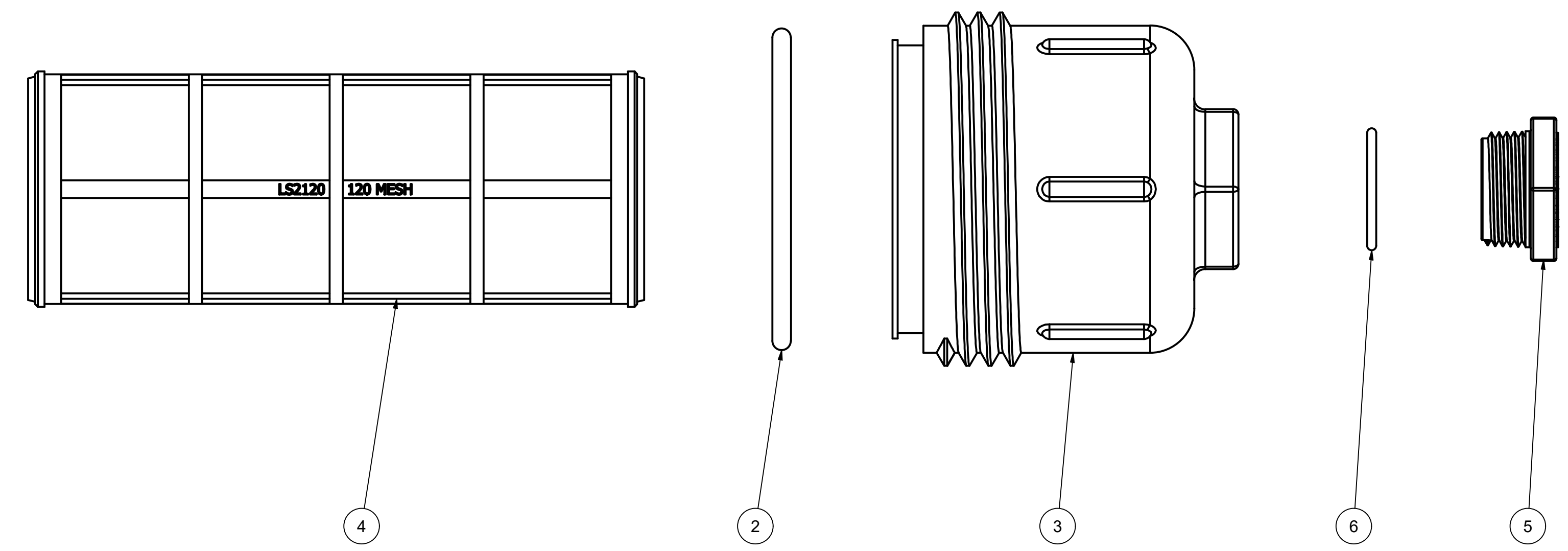

SECTION A-A
SCALE 1 : 1

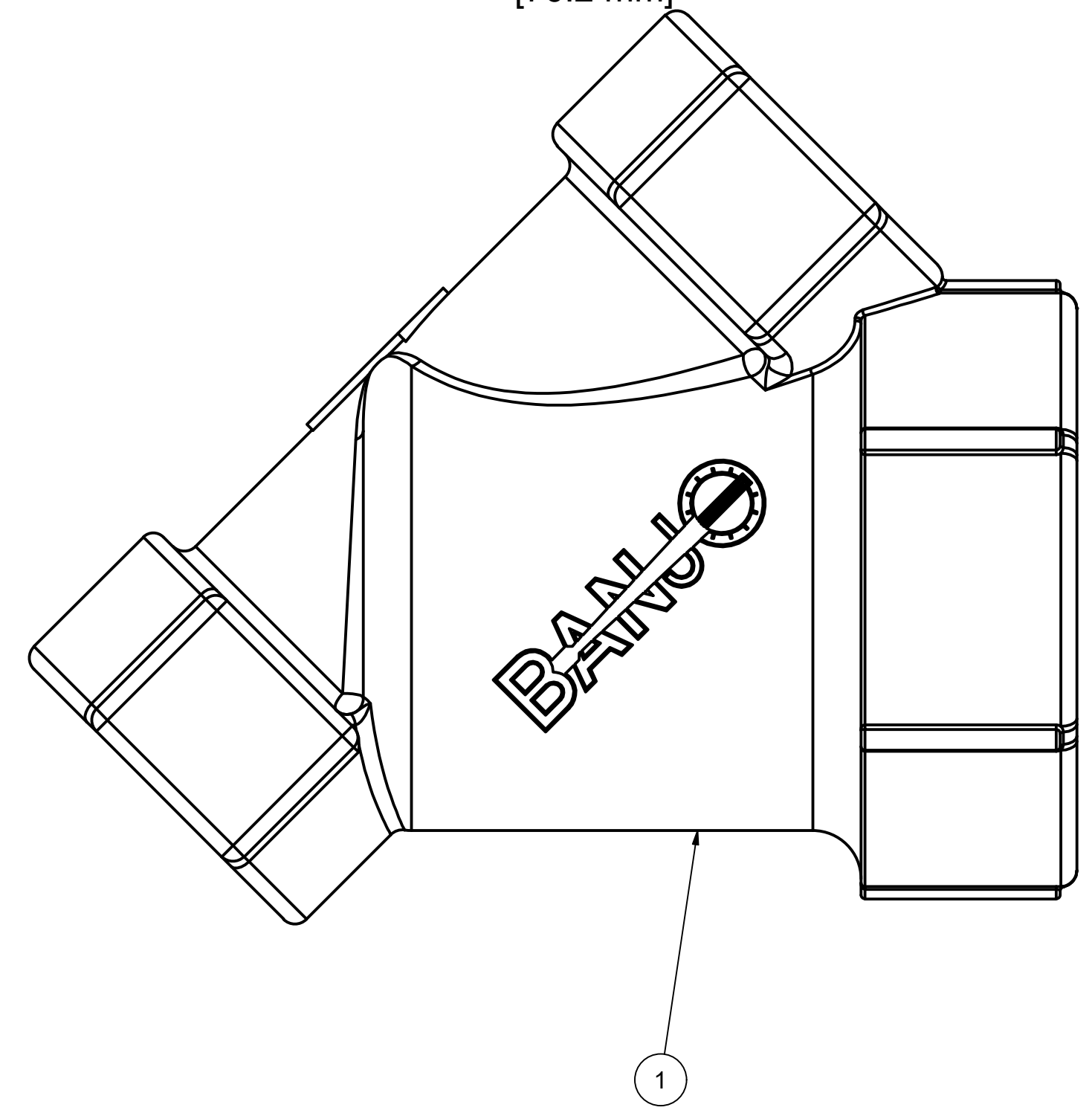

THIS DRAWING AND ALL INFORMATION CONTAINED THEREON ARE THE EXCLUSIVE PROPERTY OF BANJO CORPORATION.
UNLESS SPECIFICALLY NOTED, THIS DRAWING AND ITEMS SHOWN ON THIS DRAWING ARE SUBJECT TO CHANGE AT ANY TIME.

BANJO CORPORATION
A UNIT OF IDEX CORPORATION
150 BANJO DRIVE, CRAWFORDSVILLE, IN 47933
WEB SITE: WWW.BANJOCORP.COM
E-MAIL: BANJOSALES@IDEXCORP.COM

DESCRIPTION:
1-1/2" LINE STRAINER-120 MESH SCREEN
PART NUMBER:
LS150-120