

SECTION B-B  
SCALE 1 : 1

PARTS LIST			
ITEM	QTY	PART NUMBER	DESCRIPTION
1	1	LS150-B	1 1/2" LINE STRAINER BODY
2	1	LS150-G	AS568A -339 O-RING, EPDM, BLACK
3	1	LS150XC	1 1/2" & 2" LS CAP
4	1	LS250	2" LS SCREEN - 50 MESH
5	1	LSQ200-PL	1" NPT LINE STRAINER PLUG
6	1	LSQ200-R	AS568A -123 O-RING, EPDM, BLACK
7	1	LST100-D	DECAL (N/S)

\*NOTE:  
ADDITIONAL CLEARANCE REQ'D  
FOR SCREEN REMOVAL: 7"

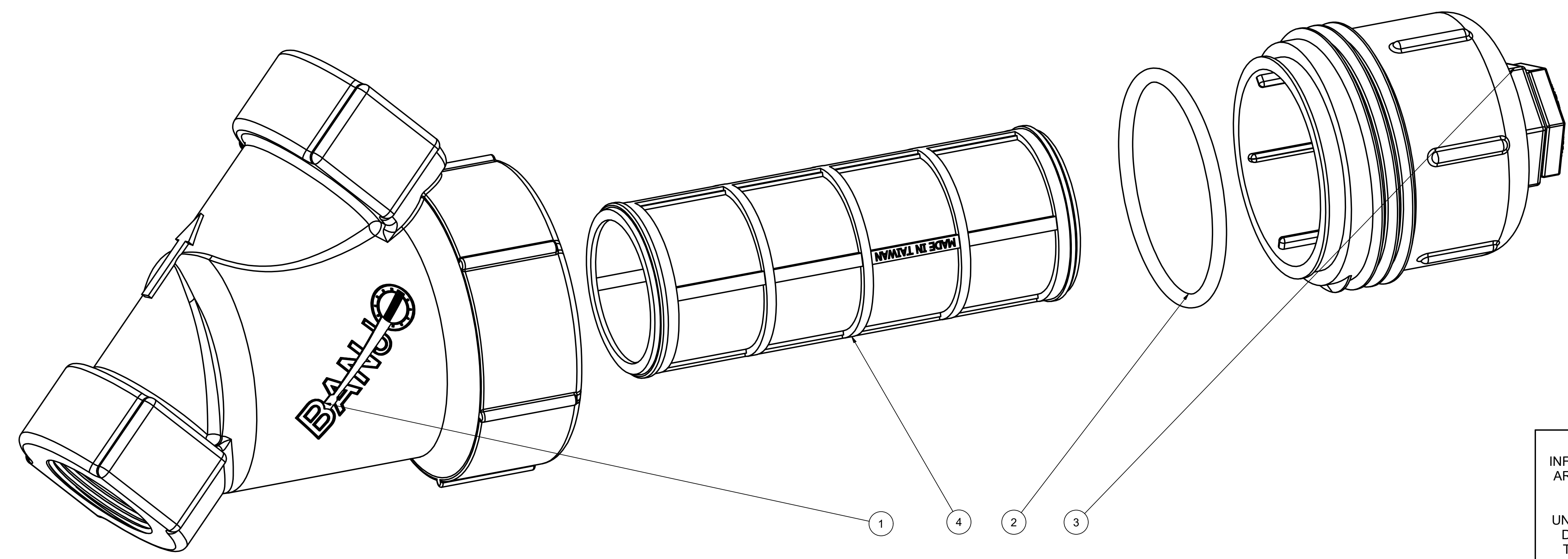

THIS DRAWING AND ALL INFORMATION CONTAINED THEREON ARE THE EXCLUSIVE PROPERTY OF BANJO CORPORATION.

UNLESS SPECIFICALLY NOTED, THIS DRAWING AND ITEMS SHOWN ON THIS DRAWING ARE SUBJECT TO CHANGE AT ANY TIME.

**BANJO CORPORATION**

BANJO CORPORATION  
150 BANJO DRIVE, CRAWFORDSVILLE, IN 47933  
WEB SITE: WWW.BANJO.CORP.COM  
E-MAIL: BANJOSALES@IDEXCORP.COM

DESCRIPTION  
1-1/2" LINE STRAINER 50 MESH

PART NUMBER  
LS150-50