

8 7 6 5 4 3 2 1

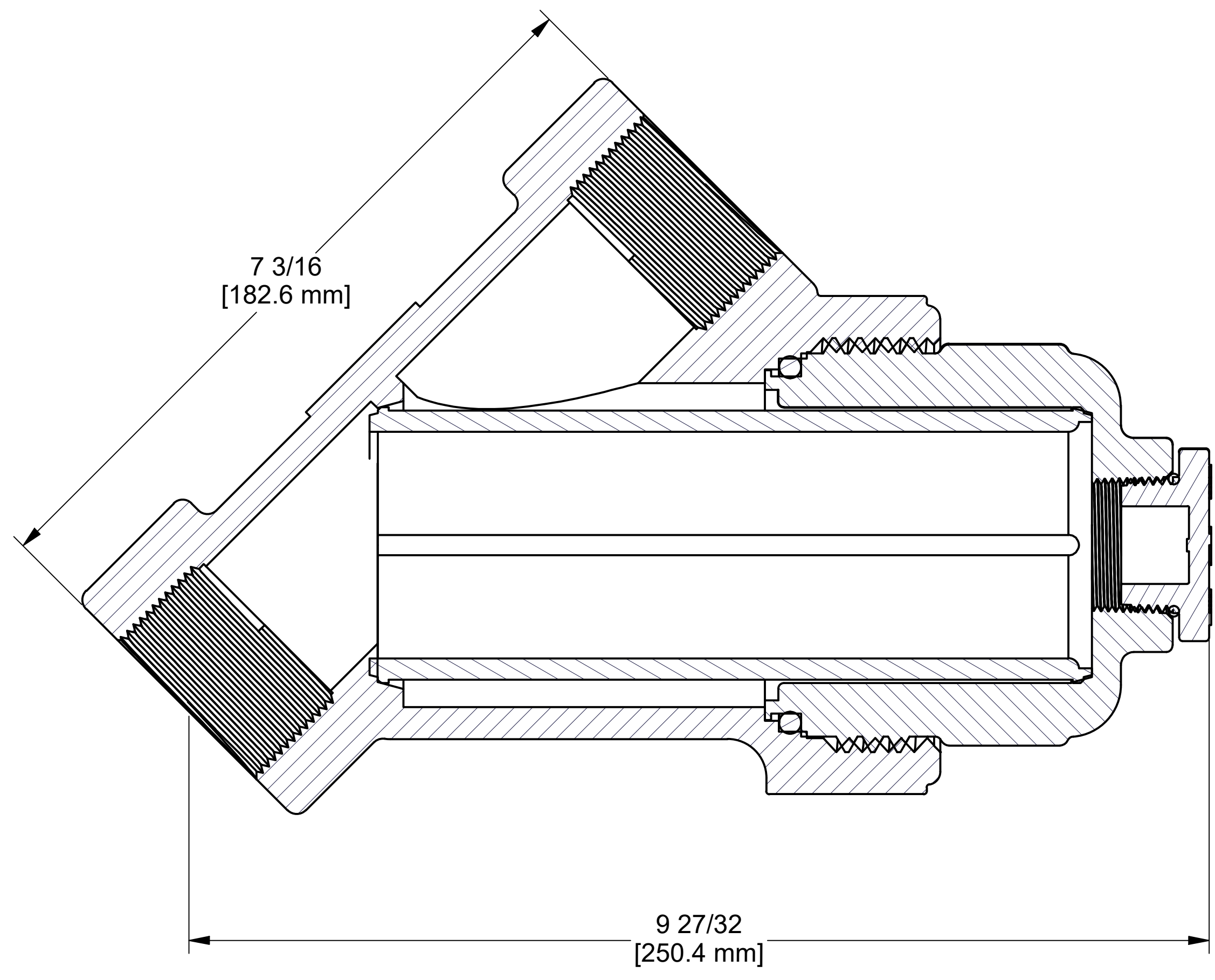

PARTS LIST			
ITEM	QTY	PART NUMBER	DESCRIPTION
1	1	LS150-B	1 1/2" LINE STRAINER BODY
2	1	LS150-CV	LS CAP ASSY - FKM
2-1	1	LS150XC	1 1/2" & 2" LS CAP
2-2	1	LSQ200-PL	LINE STRAINER PLUG
2-3	1	LSQ200-RV	2-123 FKM O-RING
2-4	1	VL1005	FKM LABEL
3	1	LS150-GV	AS568A -339 O-RING, FKM, BROWN
4	1	LS250	2" LS SCREEN - 50 MESH
5	1	LST100-D	DECAL FOR TEE STRNR 3/4 - 1 1/2 (N/S)

*NOTE:
ADDITIONAL CLEARANCE REQ'D
FOR SCREEN REMOVAL: 7"

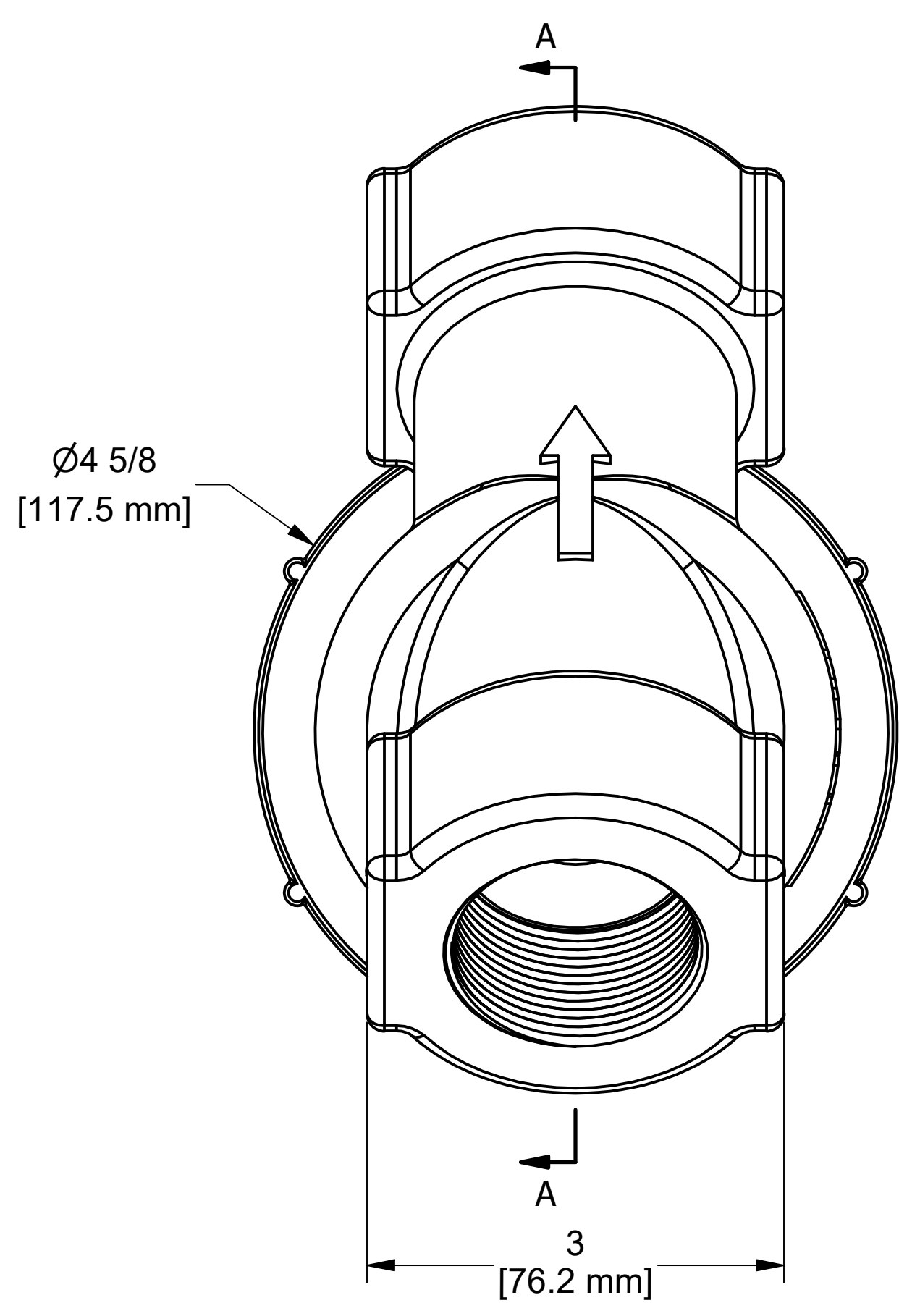
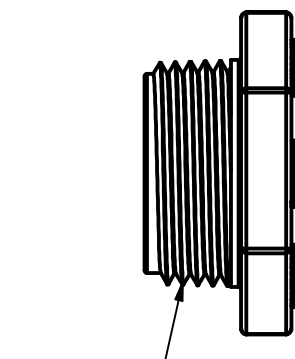
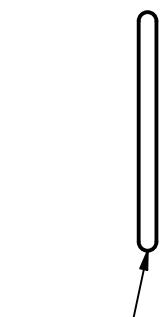
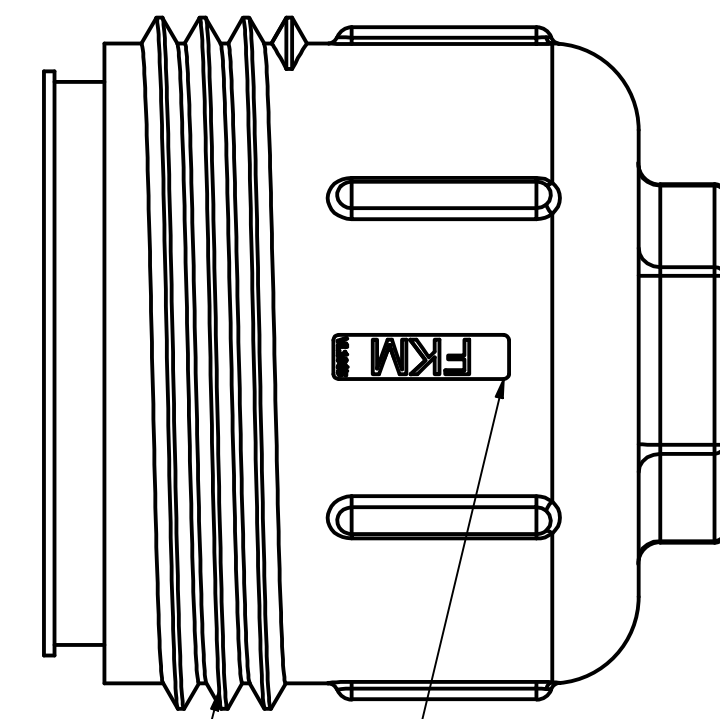
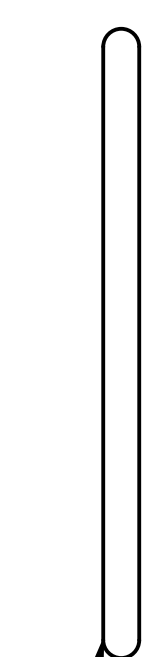
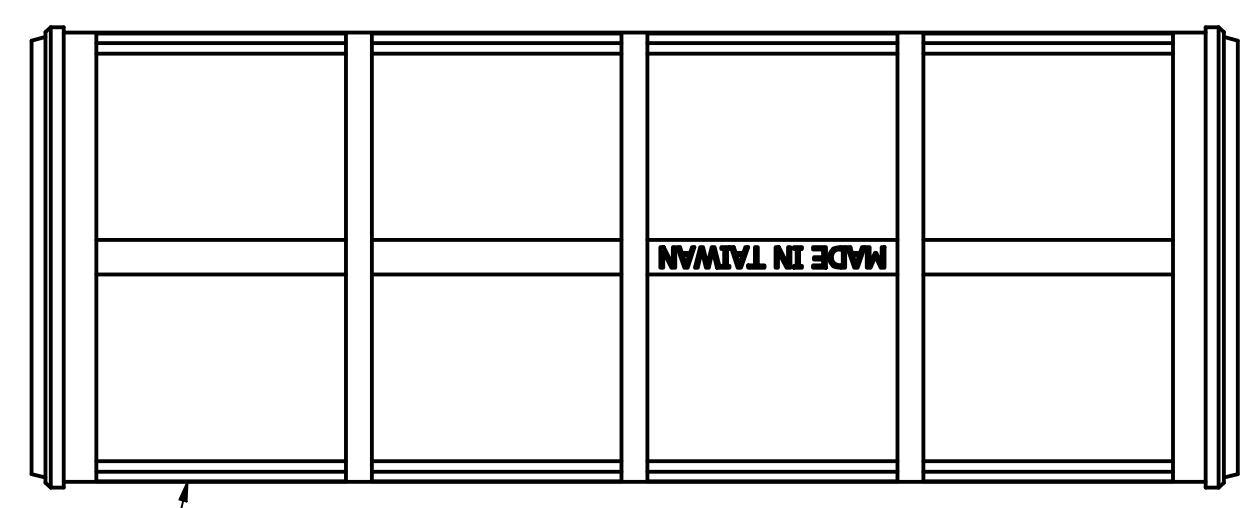
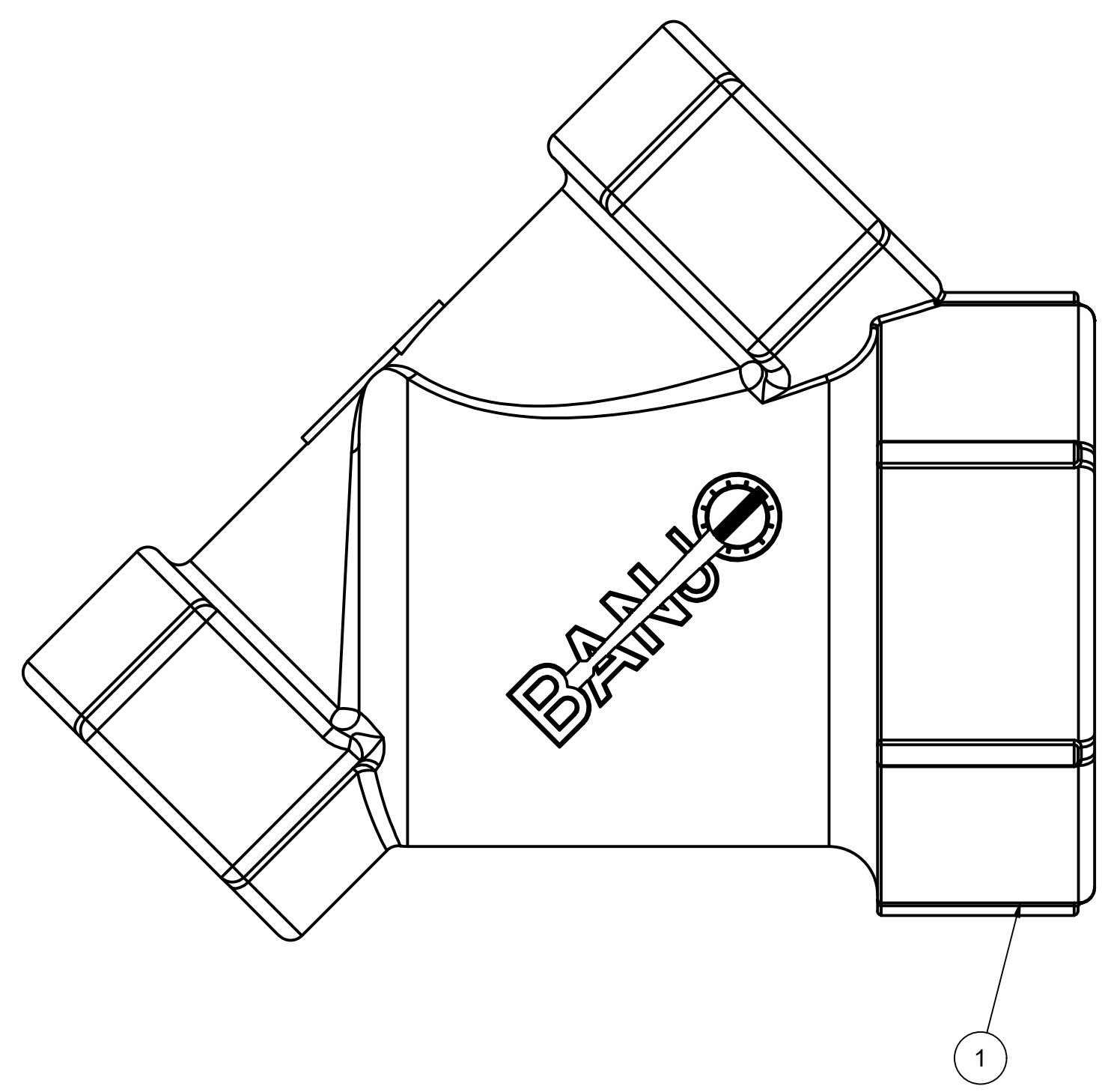

THIS DRAWING AND ALL INFORMATION CONTAINED THEREON ARE THE EXCLUSIVE PROPERTY OF BANJO CORPORATION.
UNLESS SPECIFICALLY NOTED, THIS DRAWING AND ITEMS SHOWN ON THIS DRAWING ARE SUBJECT TO CHANGE AT ANY TIME.

BANJO CORPORATION
150 BANJO DRIVE, CRAWFORDSVILLE, IN 47933
WEB SITE: WWW.BANJO.CORP.COM
E-MAIL: BANJOSALES@IDEXCORP.COM

DESCRIPTION
1 1/2" LINE STRAINER W/ 50 MESH SCREEN, FKM

PART NUMBER
LS150-50V

8 7 6 5 4 3 2 1