

8 7 6 5 4 3 2 1

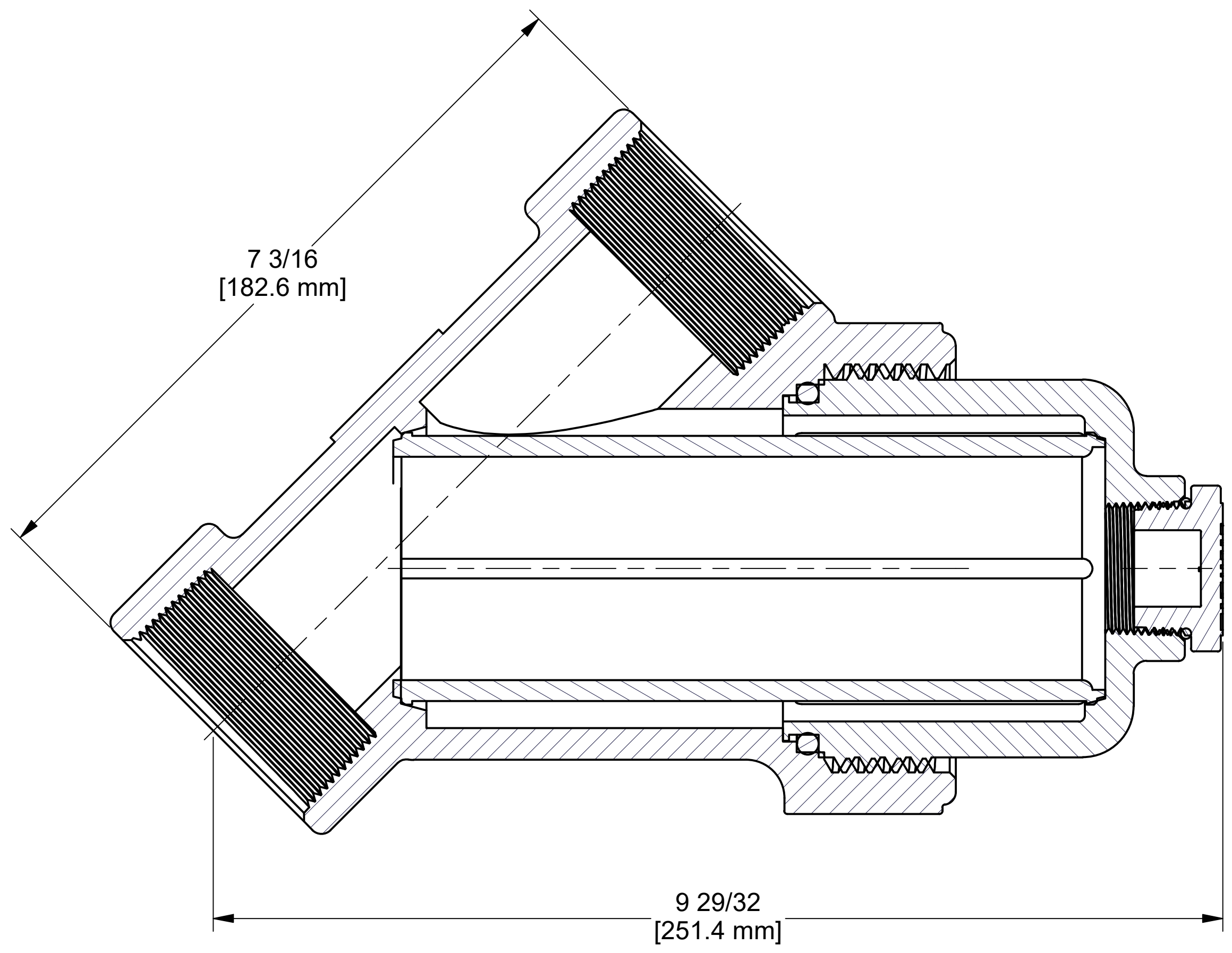
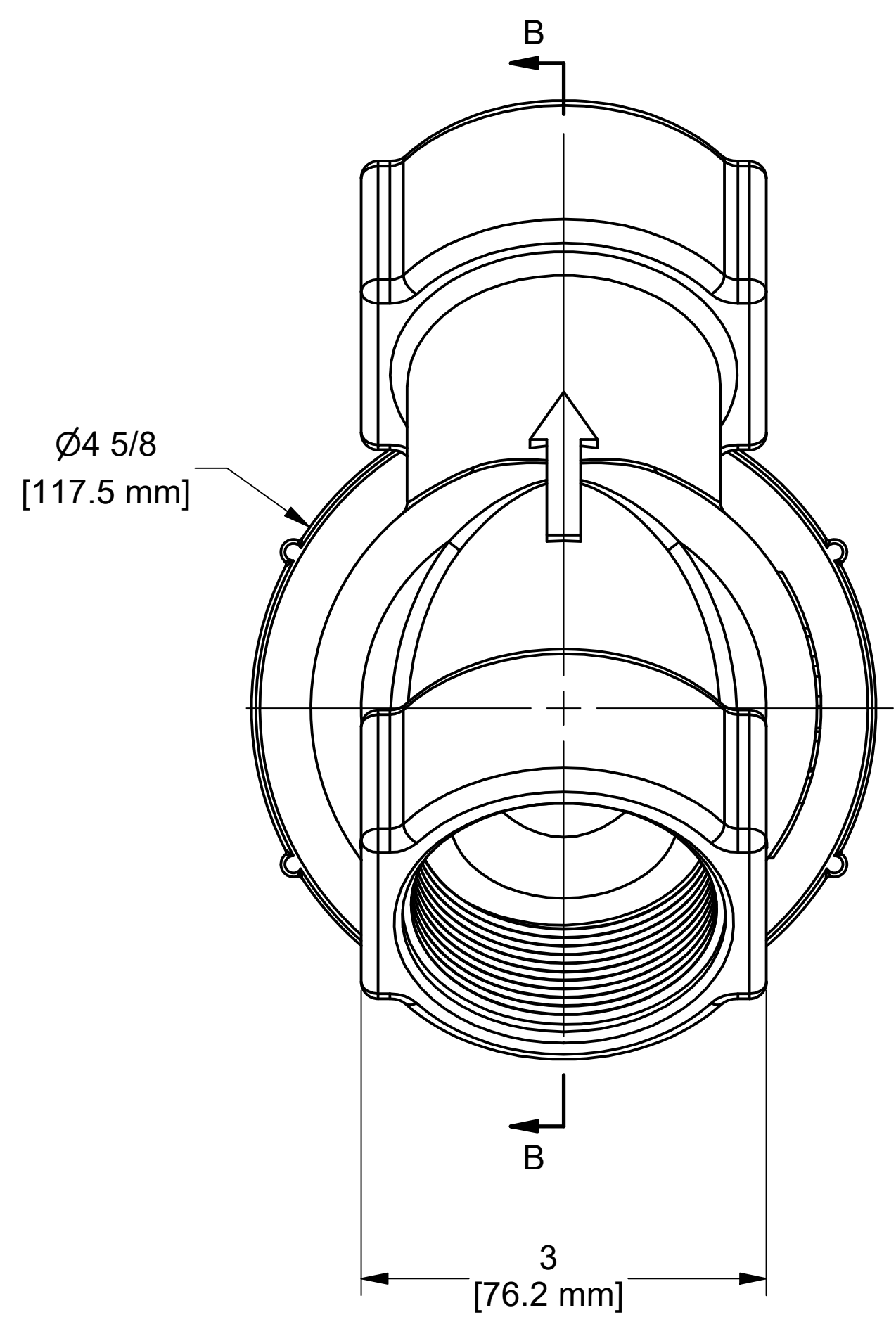

SECTION B-B
SCALE 1 : 1

PARTS LIST			
ITEM	QTY	PART NUMBER	DESCRIPTION
1	1	LS150-G	AS568A -339 O-RING, EPDM, BLACK
2	1	LS150XC	1 1/2" & 2" LS CAP
3	1	LS200-B	2" LINE STRAINER BODY
4	1	LS212	2" LS SCREEN - 12 MESH
5	1	LSQ200-PL	1" NPT LINE STRAINER PLUG
6	1	LSQ200-R	AS568A -123 O-RING, EPDM, BLACK
7	1	LST100-D	DECAL (N/S)

*NOTE:
ADDITIONAL CLEARANCE REQ'D
FOR SCREEN REMOVAL: 7"

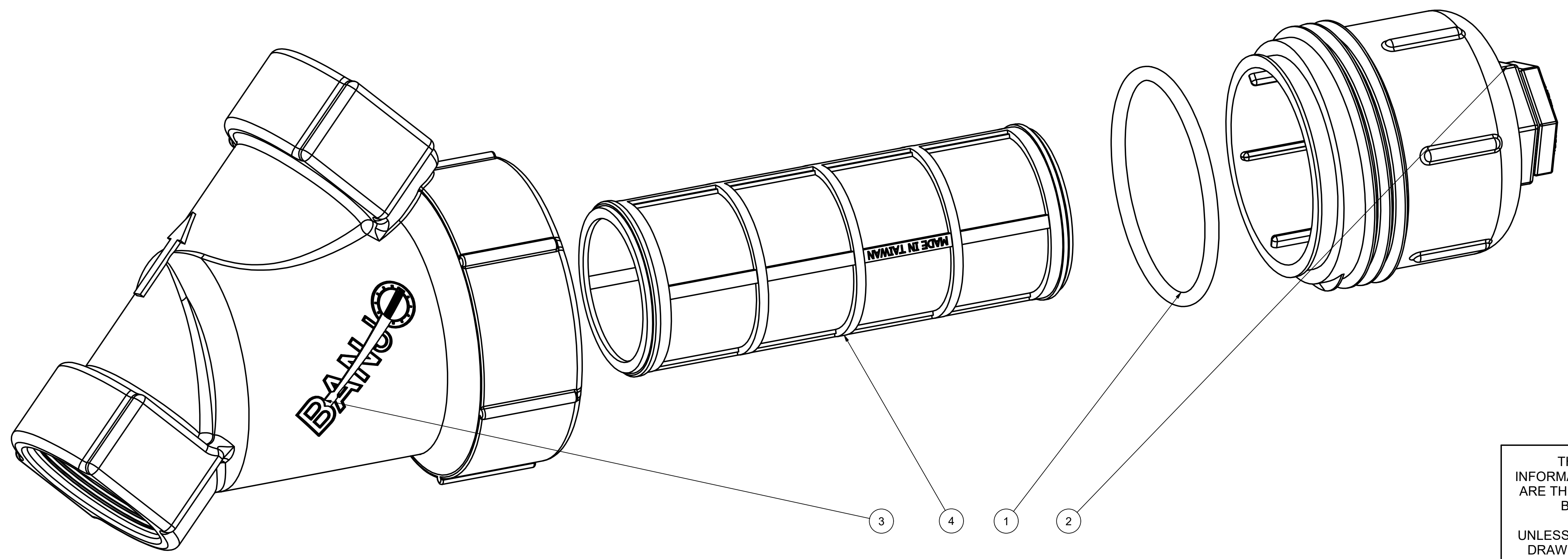

THIS DRAWING AND ALL INFORMATION CONTAINED THEREON ARE THE EXCLUSIVE PROPERTY OF BANJO CORPORATION.
UNLESS SPECIFICALLY NOTED, THIS DRAWING AND ITEMS SHOWN ON THIS DRAWING ARE SUBJECT TO CHANGE AT ANY TIME.

BANJO CORPORATION 150 BANJO DRIVE, CRAWFORDSVILLE, IN 47933 WEB SITE: WWW.BANJO.CORP.COM E-MAIL: BANJOSALES@IDEXCORP.COM	
DESCRIPTION	2" LINE STRAINER 12 MESH
PART NUMBER	LS200-12

8 7 6 5 4 3 2 1