

MACHINE THIS SURF. JUST ENOUGH TO CLEAN UP AND GET RID OF MISMATCH AT PARTING LINE

**NOTES:**

DO NOT SCALE PRINT  
 MACHINE FROM LS300ECX.  
 DIMS NOT SHOWN SAME AS LS300ECX.  
 CREATED TO ELIMINATE CAVITY MISMATCH AT PARTING LINE IN SEAL AREA.

TOLERANCE UNLESS OTHERWISE SPECIFIED DECIMALS 0.00 = +/- 0.010 DECIMALS 0.000 = +/- 0.005 FRACTIONS 1/X = +/- 1/32 ANGLES = +/- 1 BREAK ALL SHOWN CORNERS W/ 1/32 R UNLESS OTHERWISE SPECIFIED			
DRAWN MJC CHECKED QA MFG APPROVED		<b>BANJO CORPORATION</b> 150 BANJO DRIVE, CRAWFORDSVILLE, IN 47933 TITLE 3" LINE STRAINER END CAP	
		SIZE B	DWG TYPE LS300EC
		DWG NO LS300EC	REV 000
		SCALE	SHEET 1 OF 2

# QUALITY CONTROL APPROVAL PRINT

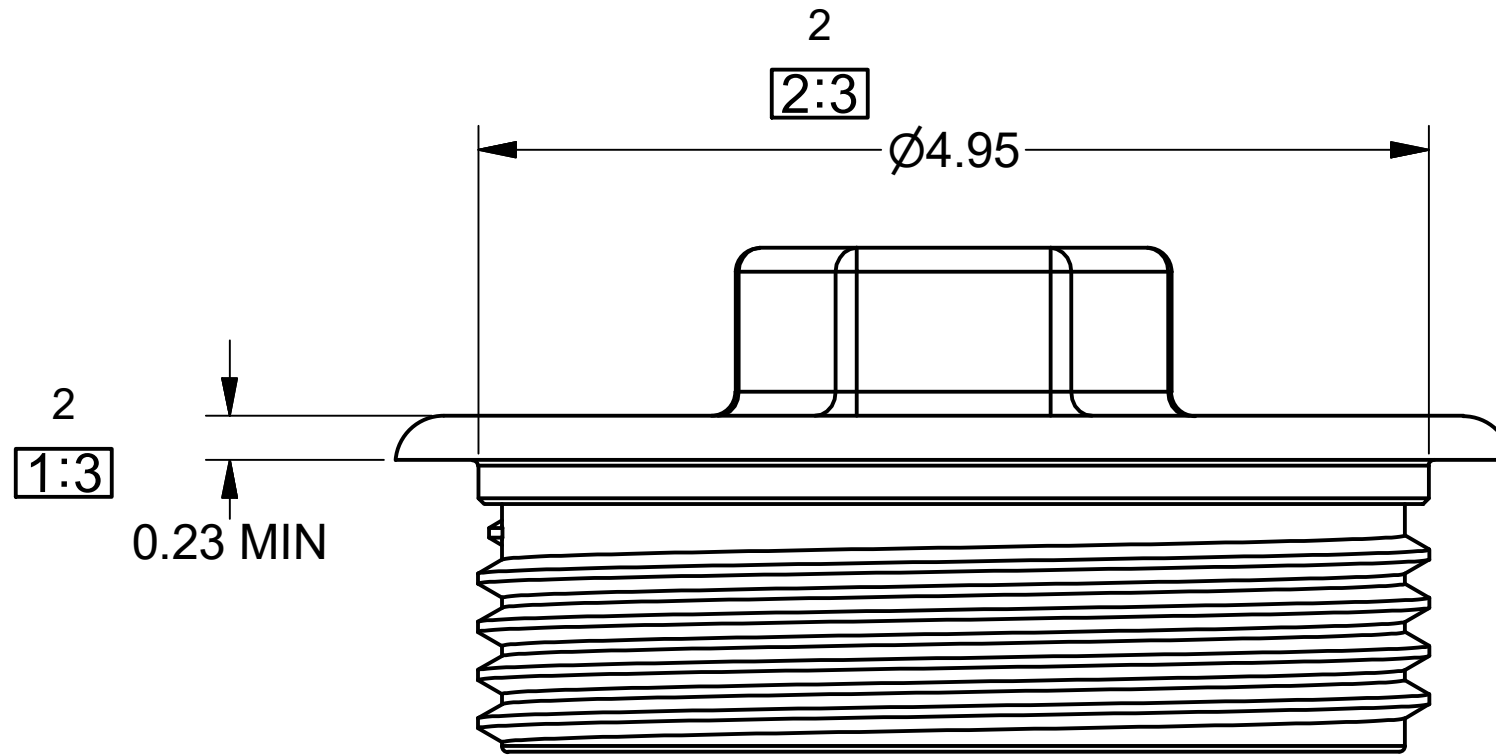

TOLERANCE UNLESS OTHERWISE SPECIFIED DECIMALS 0.00 = +/- 0.010 DECIMALS 0.000 = +/- 0.005 FRACTIONS 1/X = +/- 1/32 ANGLES = +/- 1 BREAK ALL SHOWN CORNERS W/ 1/32 R UNLESS OTHERWISE SPECIFIED			
DRAWN	MJC	<b>BANJO CORPORATION</b>	
CHECKED	3/20/2009	150 BANJO DRIVE, CRAWFORDSVILLE, IN 47933	
QA		TITLE	
MFG		3" LINE STRAINER END CAP	
APPROVED		SIZE	DWG TYPE
		B	INF
		DWG NO	REV
		LS300EC	000
		SHEET 2 OF 2	