

Parts List			
ITEM	QTY	PART NUMBER	DESCRIPTION
2	1	LSQ200-B	2" LINE STRAINER BODY W/ MALE ADAPTER BOWL
3	1	LSQ200-C	LSQ LINE STRAINER CAP
1	1	LS2120	2" LS SCREEN - 120 MESH
4	1	LST1100D	100 PSI DECAL (N/S)

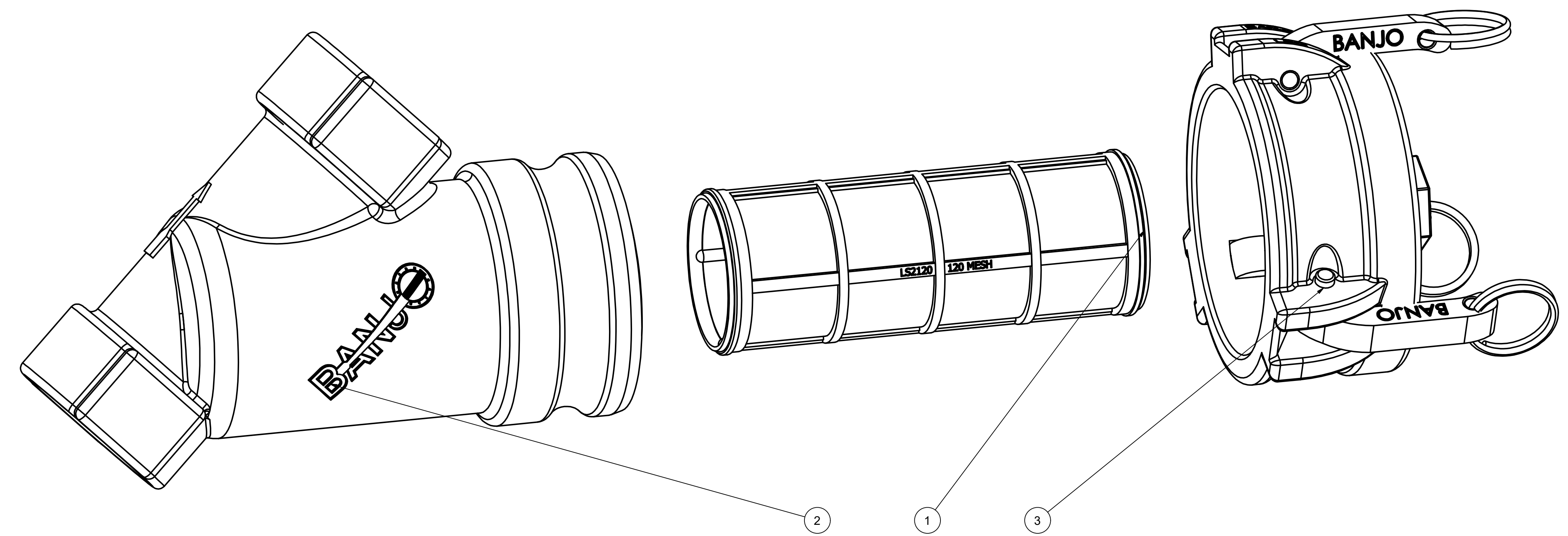

NOTE:
ADDITIONAL CLEARANCE REQ'D FOR SCREEN
REMOVAL: 7"

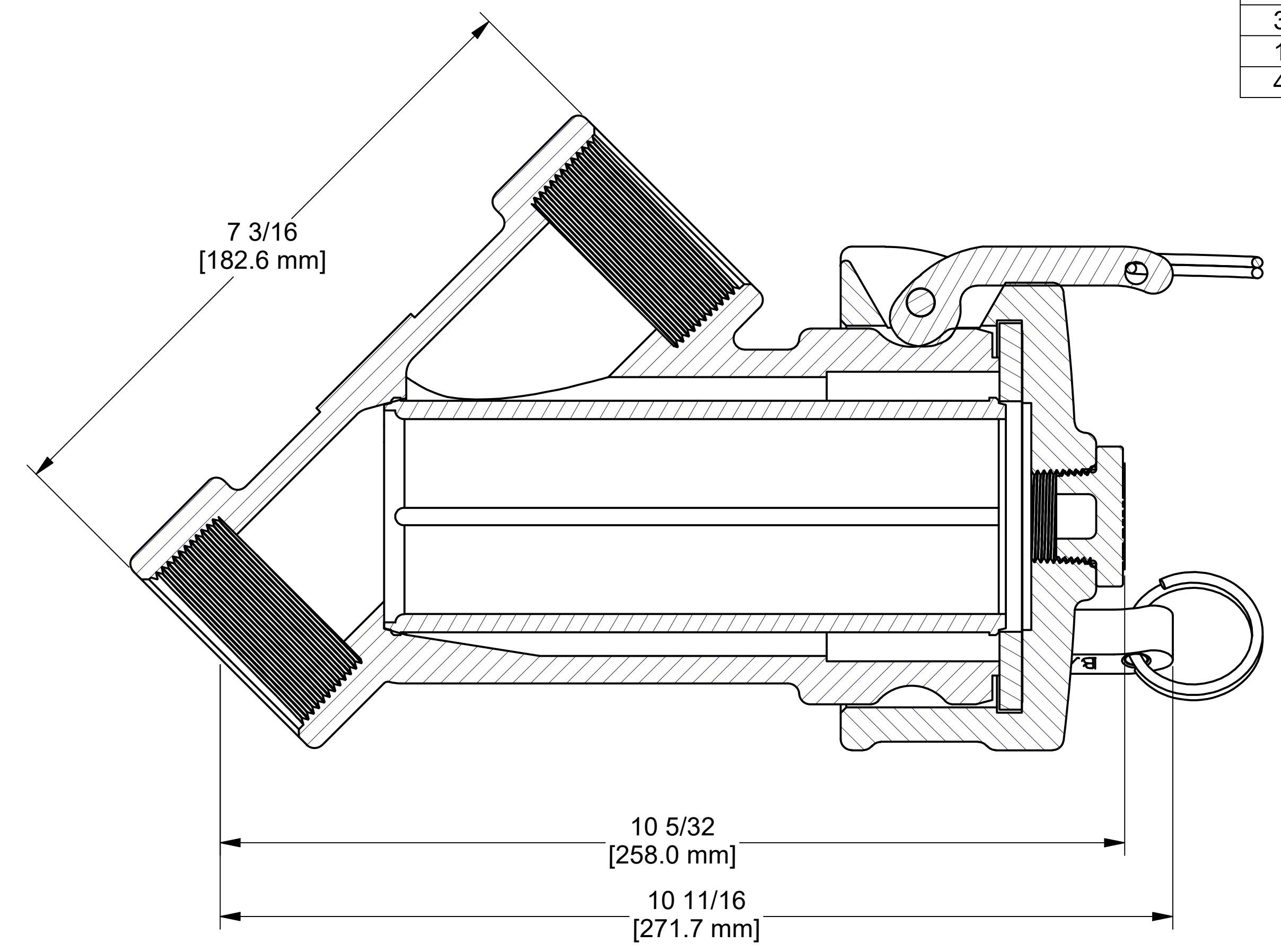
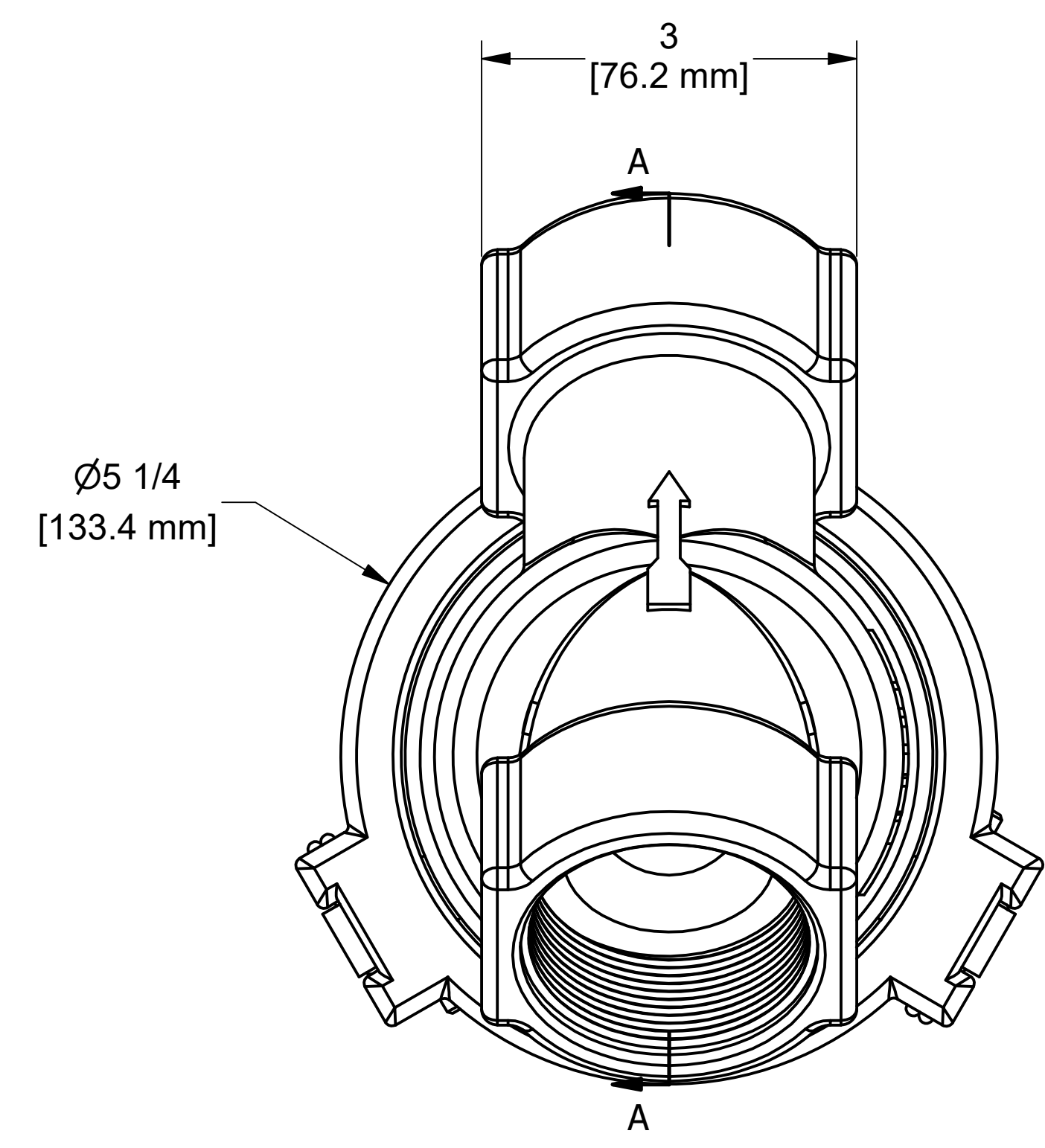

THIS DRAWING AND ALL INFORMATION CONTAINED THEREON ARE THE EXCLUSIVE PROPERTY OF BANJO CORPORATION.
UNLESS SPECIFICALLY NOTED, THIS DRAWING AND ITEMS SHOWN ON THIS DRAWING ARE SUBJECT TO CHANGE AT ANY TIME.

BANJO CORPORATION 150 BANJO DRIVE, CRAWFORDSVILLE, IN 47933 WEB SITE: WWW.BANJO.CORP.COM E-MAIL: BANJOSALES@DEXCORP.COM	
DESCRIPTION	2" NPT LINE STRAINER W/ 120 MESH SCREEN
PART NUMBER	LSQ200-120