

\*NOTE:  
5 3/4" ADDITIONAL CLEARANCE  
REQ'D FOR SCREEN REMOVAL.

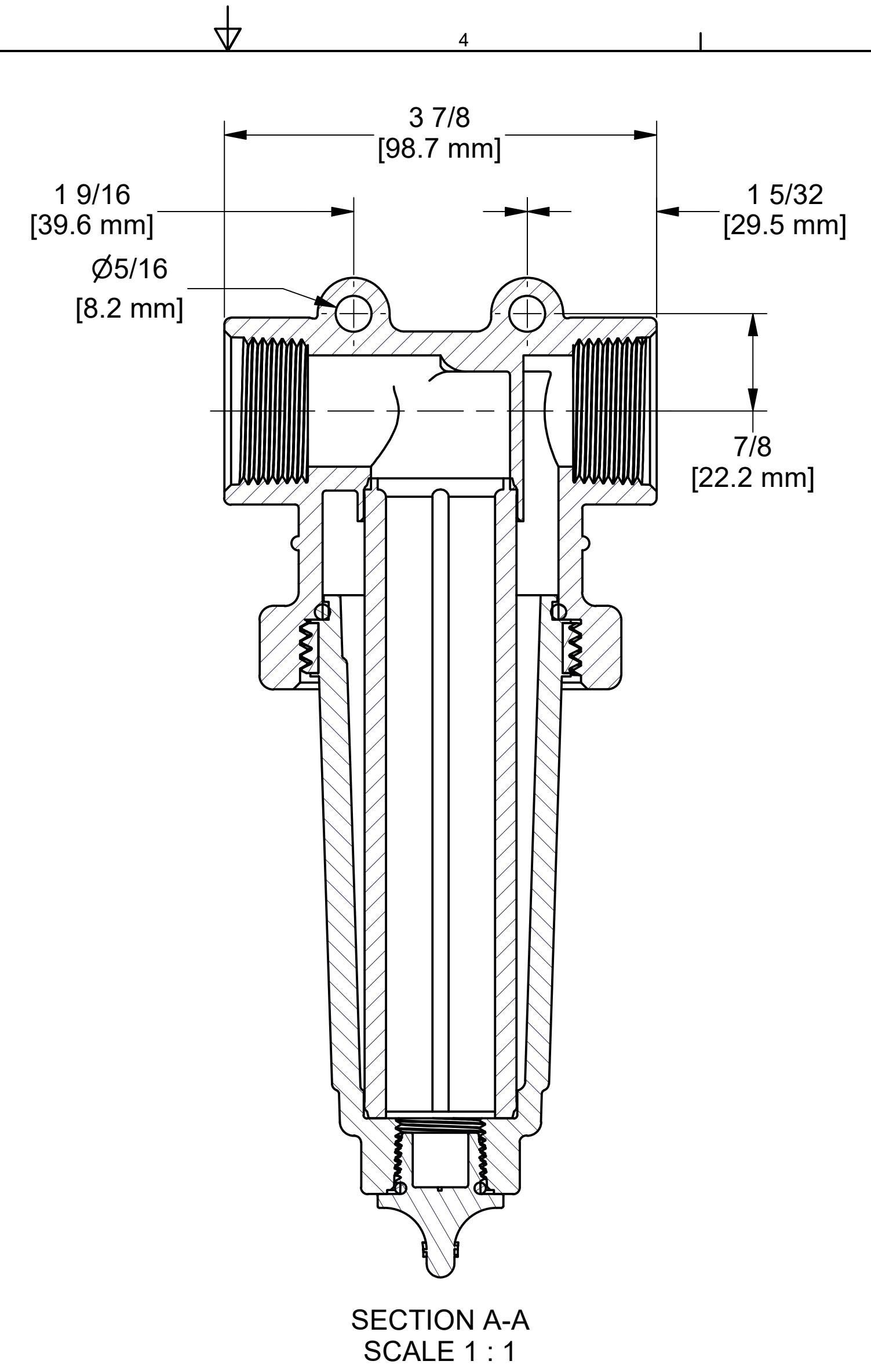

SECTION A-A  
SCALE 1 : 1

Parts List			
ITEM	QTY	PART NUMBER	DESCRIPTION
2	1	12777	1/2" DRAIN PLUG
3	1	LST100-XB	1" T-STRAINER BOWL
4	1	UV15163	AS568A -114 O-RING, EPDM, BLACK
5	1	LST100-G	AS568A -226 O-RING, EDPM, BLACK
6	1	LST100-H	1" NPT T-STRAINER HEAD
7	1	LST1100	1" LST SCREEN - 100 MESH

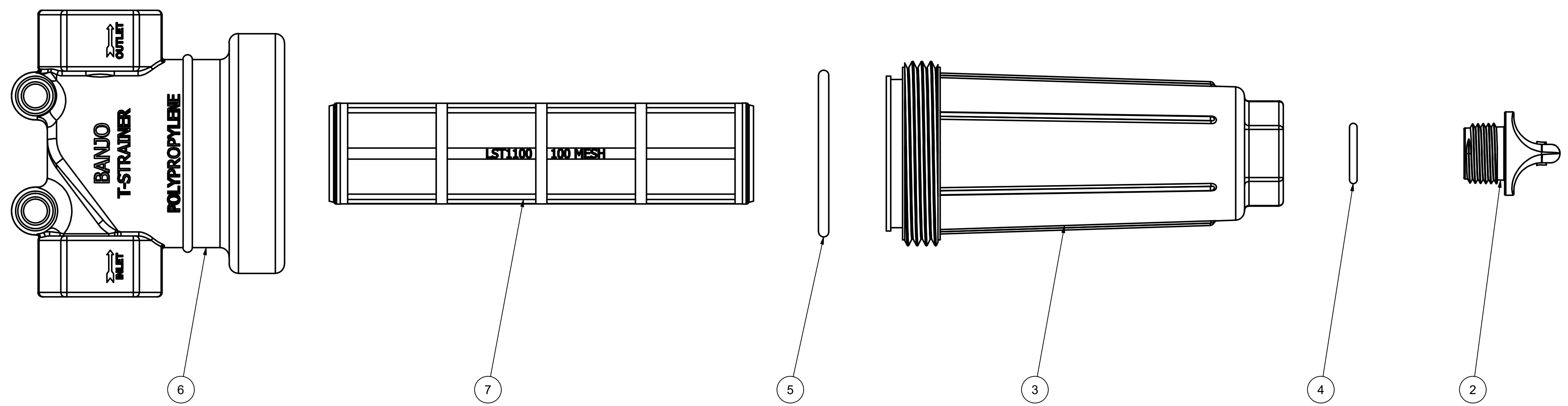
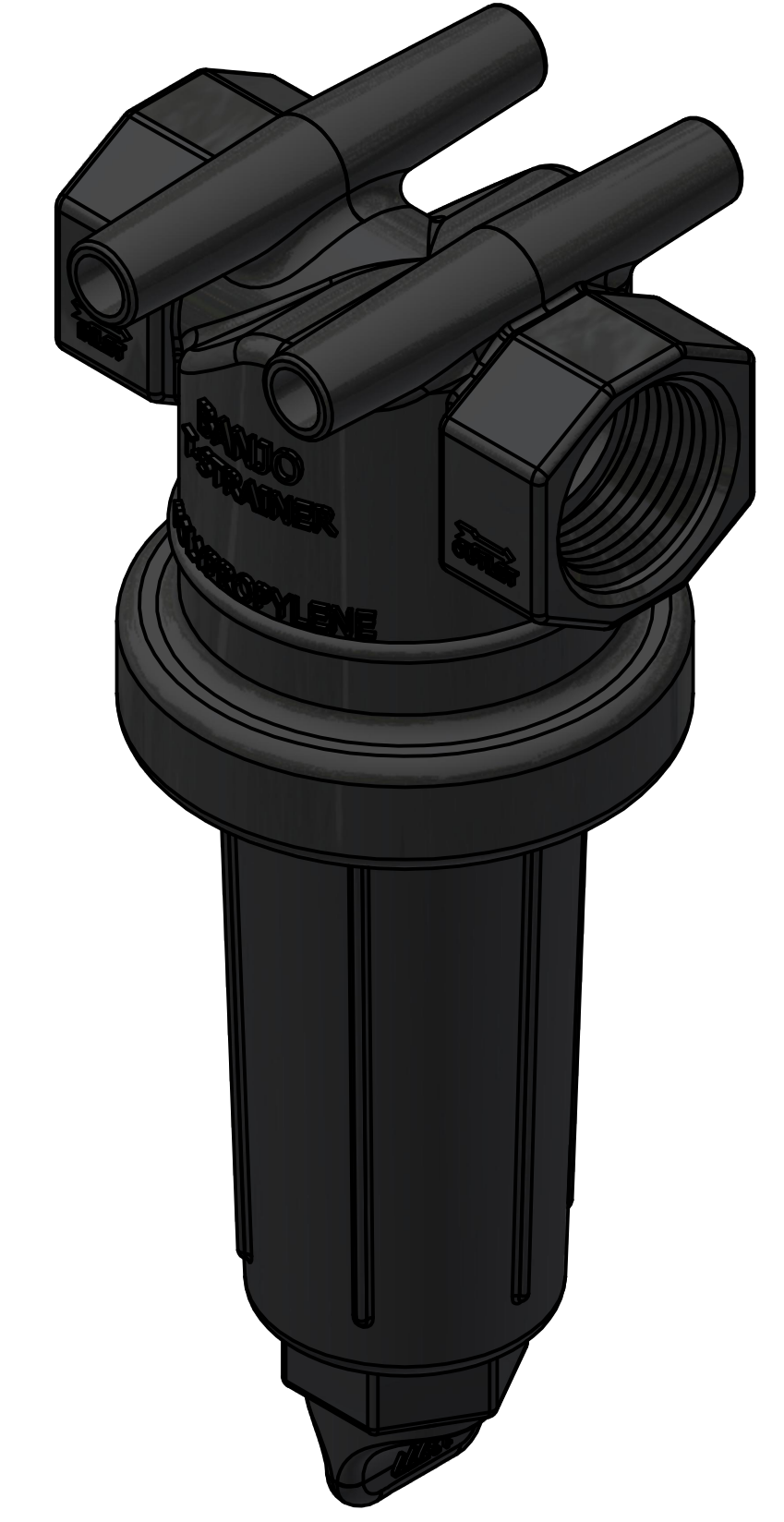

THIS DRAWING AND ALL INFORMATION CONTAINED THEREON ARE THE EXCLUSIVE PROPERTY OF BANJO CORPORATION.  
UNLESS SPECIFICALLY NOTED, THIS DRAWING AND ITEMS SHOWN ON THIS DRAWING ARE SUBJECT TO CHANGE AT ANY TIME.

**BANJO CORPORATION**  
A UNIT OF IDEX CORPORATION  
150 BANJO DRIVE, CRAWFORDSVILLE, IN 47933  
WEB SITE: WWW.BANJOCORP.COM  
E-MAIL: BANJOSALES@IDEXCORP.COM

DESCRIPTION:  
**1" POLY T-STRAINER, 100 MESH**

PART NUMBER:  
**LST100-100**