

Parts List			
ITEM	QTY	PART NUMBER	DESCRIPTION
1	1	CE050D	CE DECAL
2	1	LST125-H	1 1/2" T-STRAINER HEAD
3	1	LST1300D	300 PSI DECAL
4	1	LST150-B	1 1/2" T-Strainer Bowl Assembly
4-1	1	LSQ200-PL	LINE STRAINER PLUG
4-2	1	LSQ200-R	2-123 EPDM O-Ring
4-3	1	LST150-XB	1 1/2" T-STRAINER BOWL
5	1	LST150-G	#336 O-RING
6	1	LST1530	1 1/2" LST SCREEN - 30 MESH

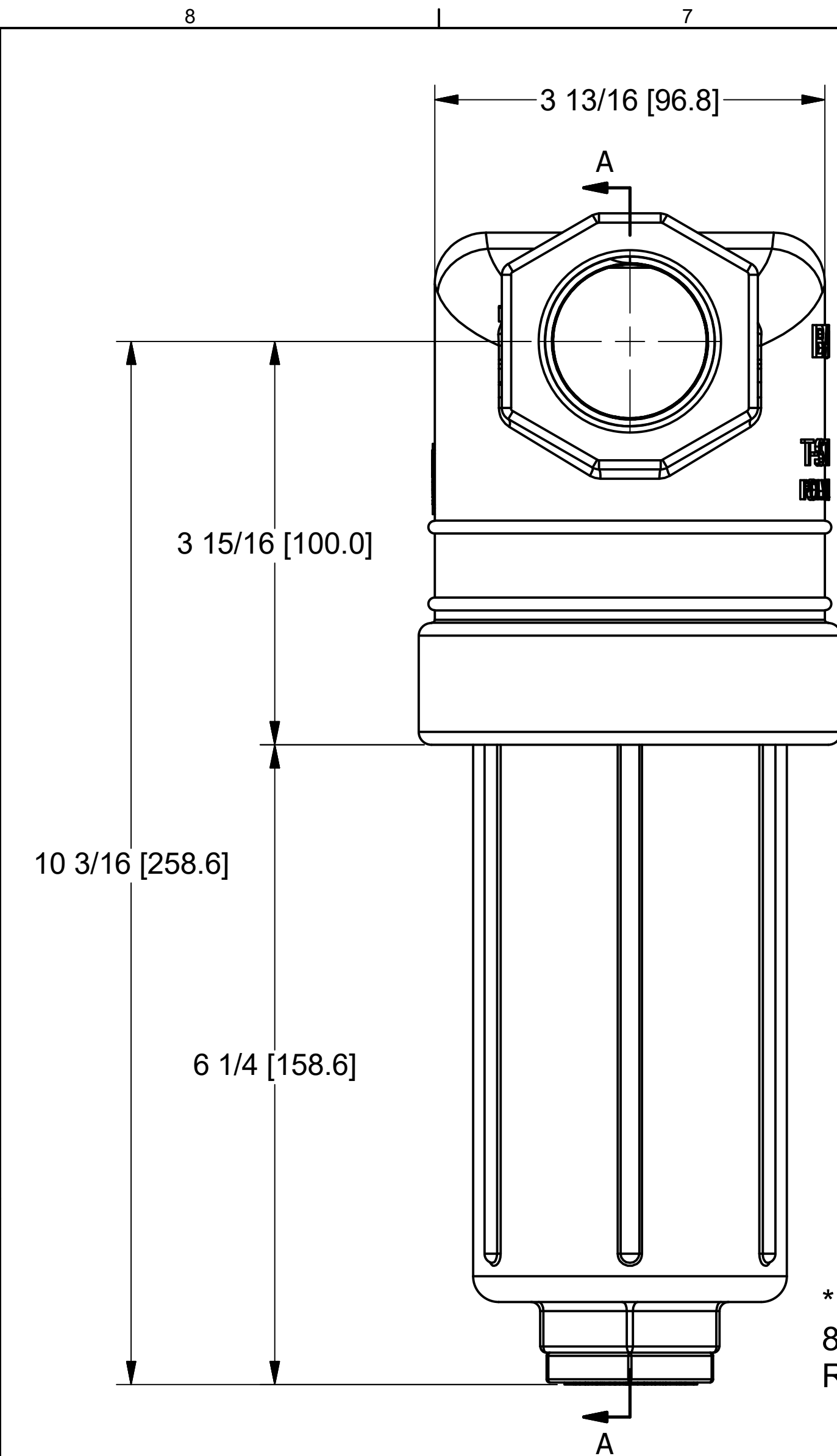

*NOTE:
8" ADDITIONAL CLEARANCE
REQ'D FOR SCREEN REMOVAL.

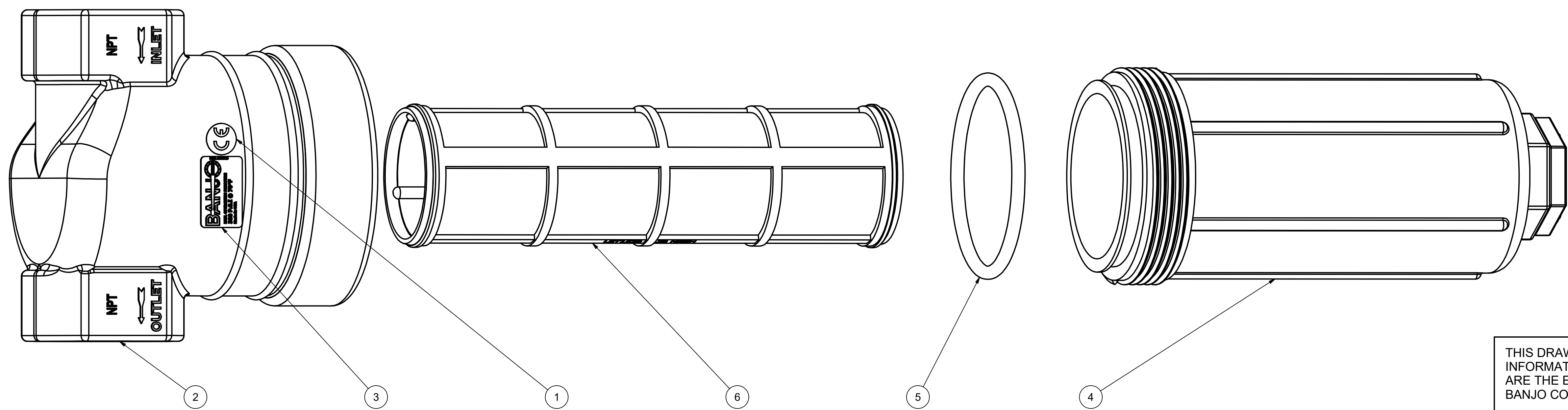
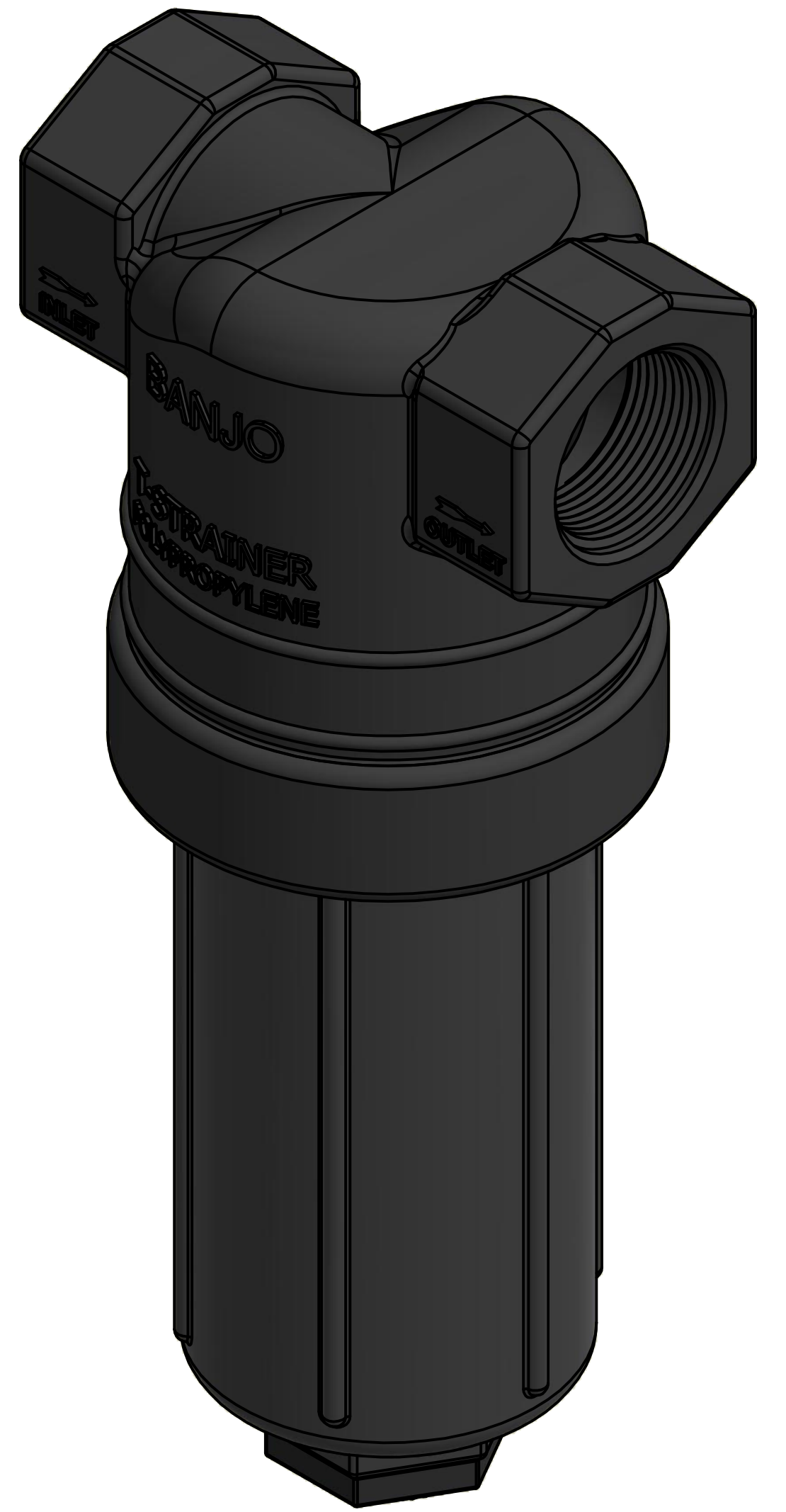
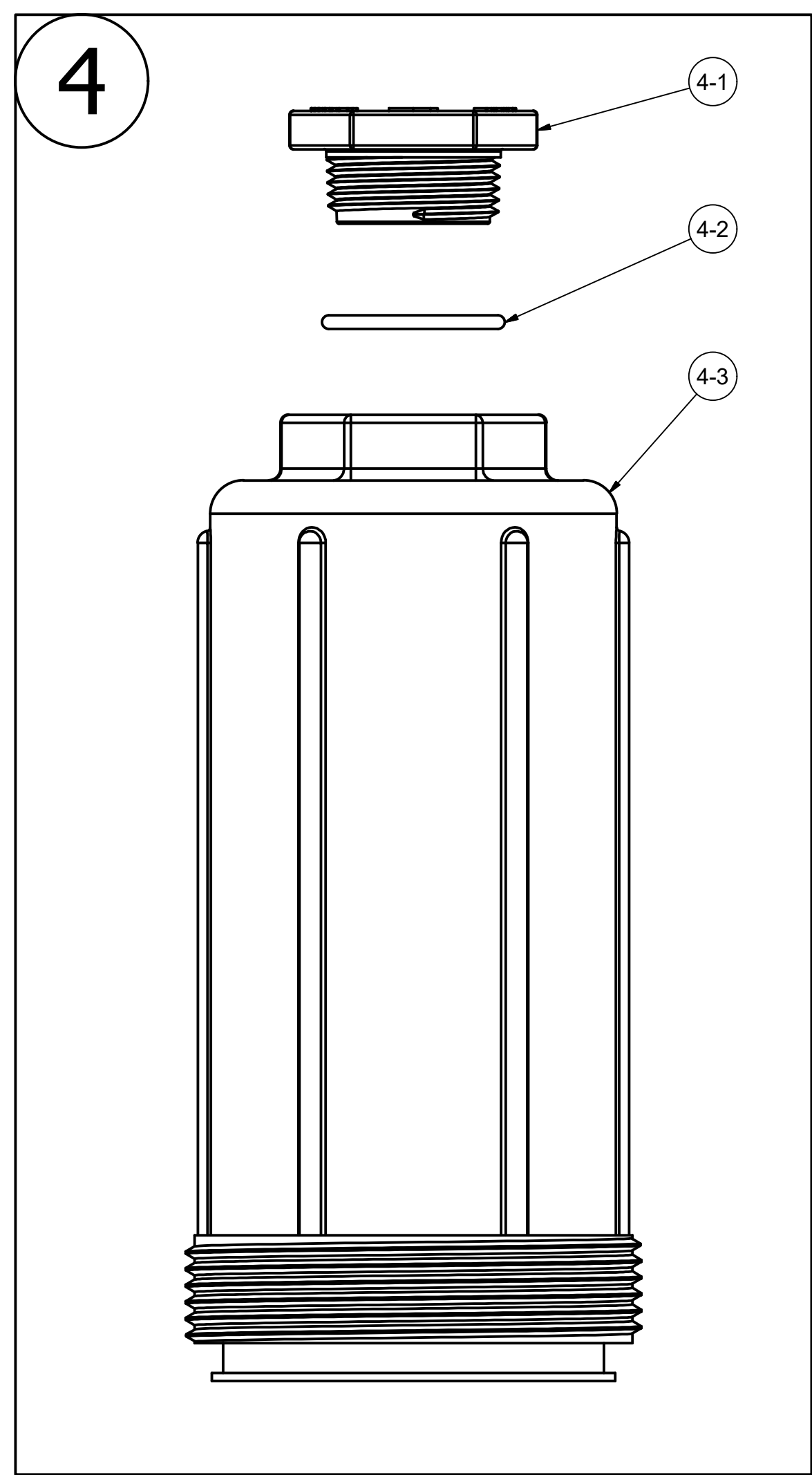
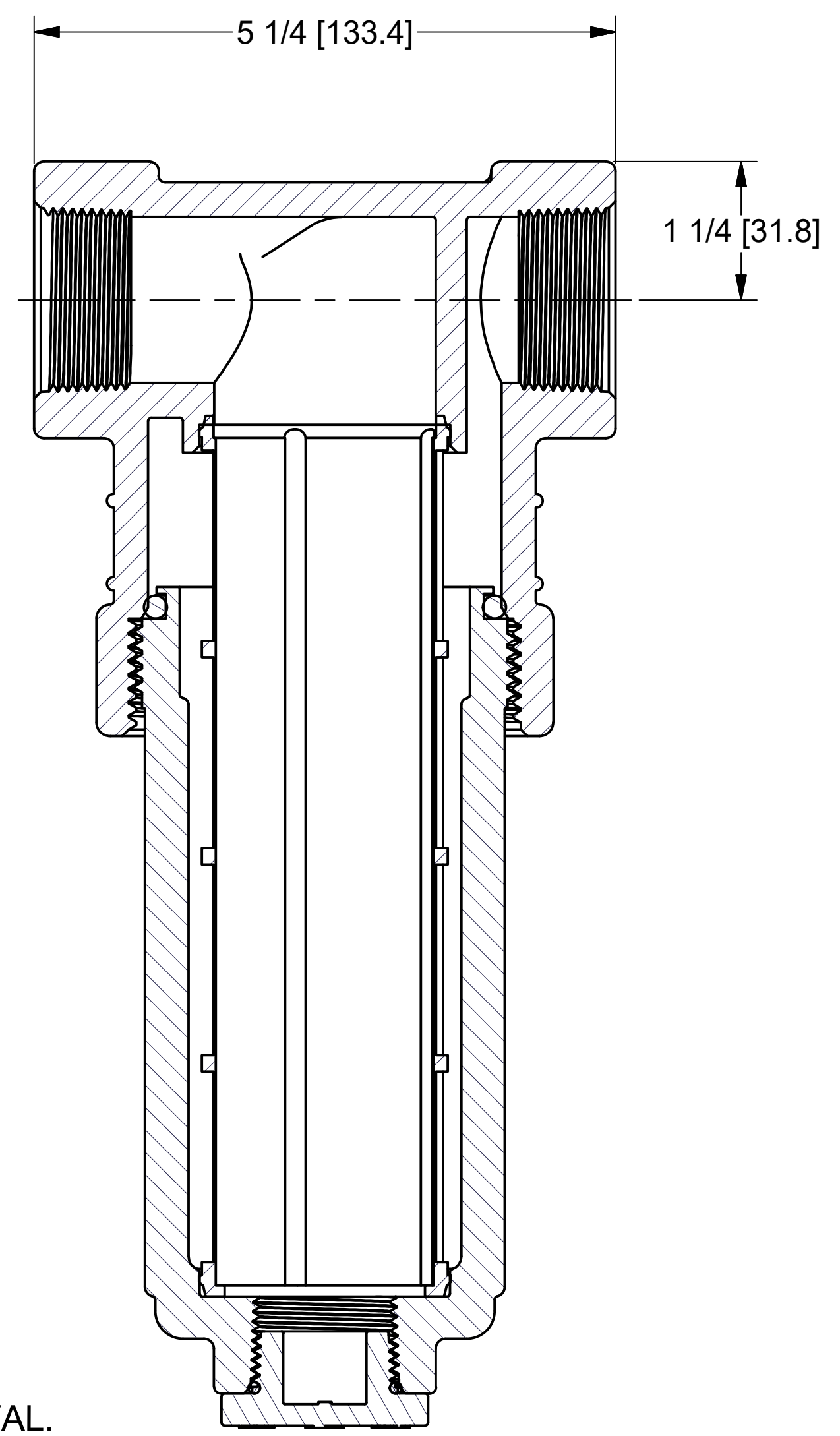

THIS DRAWING AND ALL
INFORMATION CONTAINED THEREON
ARE THE EXCLUSIVE PROPERTY OF
BANJO CORPORATION.

UNLESS SPECIFICALLY NOTED, THIS
DRAWING AND ITEMS SHOWN ON
THIS DRAWING ARE SUBJECT TO
CHANGE AT ANY TIME.

BANJO CORPORATION
150 BANJO DRIVE, CRAWFORDSVILLE, IN 47933
WEB SITE: WWW.BANJOCCORP.COM
E-MAIL: BANJOSALES@DEXCORP.COM

DESCRIPTION
1 1/4" T-STRAINER, 30 MESH

PART NUMBER
LST125-30