

\*NOTE:  
8" ADDITIONAL CLEARANCE  
REQ'D FOR SCREEN REMOVAL.

SECTION A-A  
SCALE 1

Parts List				
ITEM	QTY	PART NUMBER	DESCRIPTION	
1	1	CE050D	CE DECAL	
2	1	LST125-H	1 1/2" T-STRAINER HEAD	
3	1	LST1300D	300 PSI DECAL	
4	1	LST150-B	1 1/2" T-Strainer Bowl Assembly	
4-1	1	LSQ200-PL	LINE STRAINER PLUG	
4-2	1	LSQ200-R	2-123 EPDM O-Ring	
4-3	1	LST150-XB	1 1/2" T-STRAINER BOWL	
5	1	LST150-G	#336 O-RING	
6	1	LST1550	1 1/2" LST SCREEN 50 Mesh, SS, Poly Ribs	

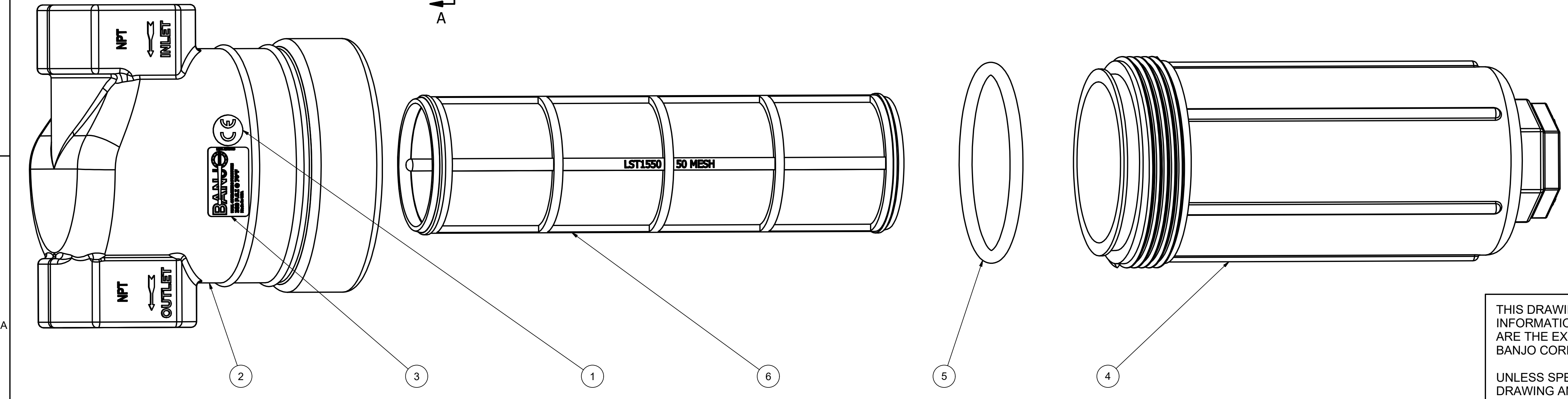

THIS DRAWING AND ALL INFORMATION CONTAINED THEREON ARE THE EXCLUSIVE PROPERTY OF BANJO CORPORATION.  
UNLESS SPECIFICALLY NOTED, THIS DRAWING AND ITEMS SHOWN ON THIS DRAWING ARE SUBJECT TO CHANGE AT ANY TIME.

**BANJO CORPORATION**  
150 BANJO DRIVE, CRAWFORDSVILLE, IN 47933  
WEB SITE: WWW.BANJO.CORP.COM  
E-MAIL: BANJOSALES@DEXCORP.COM

DESCRIPTION  
**1 1/2" T-STRAINER, 50 MESH**

PART NUMBER  
**LST125-50**