

Parts List					
ITEM	QTY	PART NUMBER	DESCRIPTION		
1	1	CE050D	CE DECAL		
2	1	LST1300D	300 PSI DECAL		
3	1	LST150-B	1 1/2" T-Strainer Bowl Assembly		
3-1	1	LSQ200-PL	LINE STRAINER PLUG		
3-2	1	LSQ200-R	2-123 EPDM O-Ring		
3-3	1	LST150-XB	1 1/2" T-STRAINER BOWL		
4	1	LST150-G	#336 O-RING		
5	1	LST150-H	1 1/2" T-STRAINER HEAD		
6	1	LST1550	1 1/2" LST SCREEN 50 Mesh, SS, Poly Ribs		

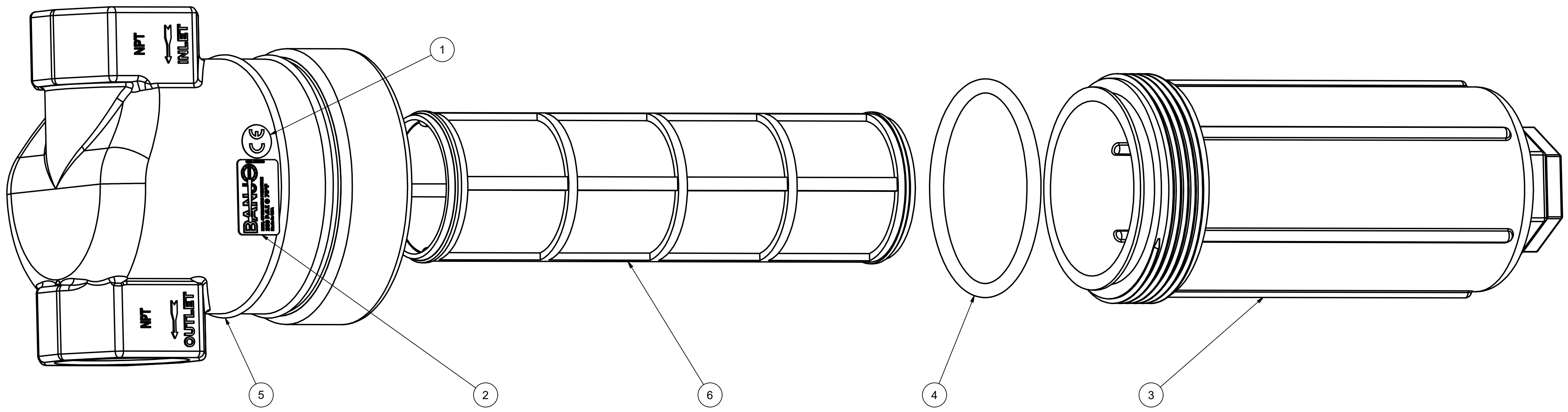

*NOTE:
8" ADDITIONAL CLEARANCE
REQ'D FOR SCREEN REMOVAL.



THIS DRAWING AND ALL INFORMATION CONTAINED THEREON ARE THE EXCLUSIVE PROPERTY OF BANJO CORPORATION.

UNLESS SPECIFICALLY NOTED, THIS DRAWING AND ITEMS SHOWN ON THIS DRAWING ARE SUBJECT TO CHANGE AT ANY TIME.

BANJO CORPORATION
150 BANJO DRIVE, CRAWFORDSVILLE, IN 47933
WEB SITE: WWW.BANJO.CORP.COM
E-MAIL: BANJOSALES@DEXCORP.COM

DESCRIPTION
1-1/2" POLY T STRAINER 50 MESH

PART NUMBER
LST150-50